

Heat-Loss Testing of Solel's UVAC3 Parabolic Trough Receiver

F. Burkholder and C. Kutscher

Technical Report
NREL/TP-550-42394
January 2008

NREL is operated by Midwest Research Institute • Battelle Contract No. DE-AC36-99-GO10337



Heat-Loss Testing of Solel's UVAC3 Parabolic Trough Receiver

Technical Report
NREL/TP-550-42394
January 2008

F. Burkholder and C. Kutscher

Prepared under Task No. CP07.3101

National Renewable Energy Laboratory
1617 Cole Boulevard, Golden, Colorado 80401-3393
303-275-3000 • www.nrel.gov

Operated for the U.S. Department of Energy
Office of Energy Efficiency and Renewable Energy
by Midwest Research Institute • Battelle

Contract No. DE-AC36-99-GO10337

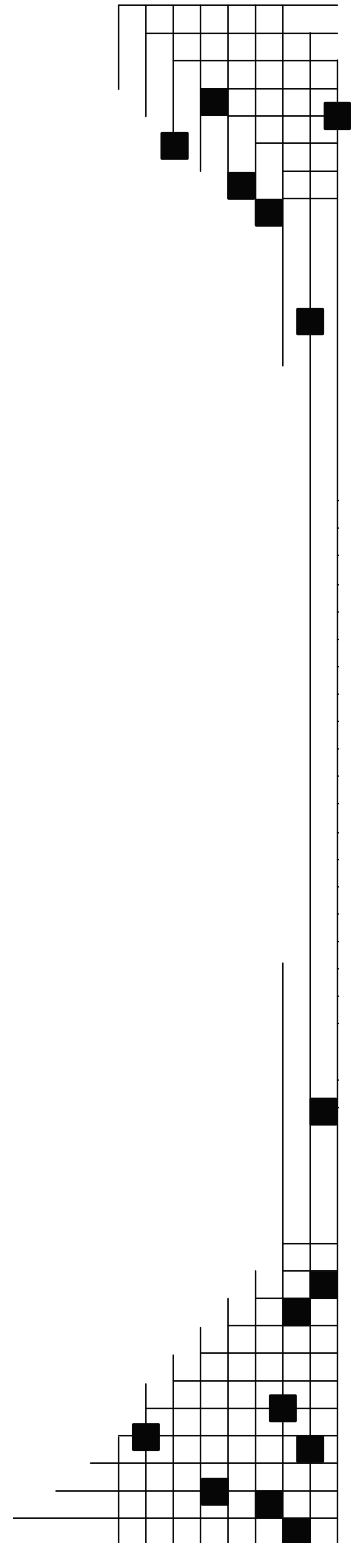

NOTICE

This report was prepared as an account of work sponsored by an agency of the United States government. Neither the United States government nor any agency thereof, nor any of their employees, makes any warranty, express or implied, or assumes any legal liability or responsibility for the accuracy, completeness, or usefulness of any information, apparatus, product, or process disclosed, or represents that its use would not infringe privately owned rights. Reference herein to any specific commercial product, process, or service by trade name, trademark, manufacturer, or otherwise does not necessarily constitute or imply its endorsement, recommendation, or favoring by the United States government or any agency thereof. The views and opinions of authors expressed herein do not necessarily state or reflect those of the United States government or any agency thereof.

Available electronically at <http://www.osti.gov/bridge>

Available for a processing fee to U.S. Department of Energy and its contractors, in paper, from:

U.S. Department of Energy
Office of Scientific and Technical Information
P.O. Box 62
Oak Ridge, TN 37831-0062
phone: 865.576.8401
fax: 865.576.5728
email: <mailto:reports@adonis.osti.gov>

Available for sale to the public, in paper, from:

U.S. Department of Commerce
National Technical Information Service
5285 Port Royal Road
Springfield, VA 22161
phone: 800.553.6847
fax: 703.605.6900
email: orders@ntis.fedworld.gov
online ordering: <http://www.ntis.gov/ordering.htm>



TABLE OF CONTENTS

Executive Summary.....	iv
Introduction	1
Test-Stand Description.....	2
Results.....	5
Uncertainty Analysis.....	10
Conclusion.....	12
Acknowledgments.....	12
References.....	13

EXECUTIVE SUMMARY

Researchers at the National Renewable Energy Laboratory completed heat-loss testing on two of Solel's UVAC3 parabolic trough receivers. The receivers showed identical heat losses within experimental uncertainty. Normalized per meter of receiver length, heat losses are 130, 200, 310, and 460 W/m at average absorber temperatures of 300°, 350°, 400°, and 450°C, respectively. Experimental uncertainty is about ±10 W/m. A correlation was developed to predict receiver heat loss as a function of the difference in °C between the average absorber temperature and ambient temperature. This correlation is:

$$\text{UVAC3 heat loss (W/m)} = 0.26 * \Delta T + 1.05 * 10^{-8} * \Delta T^4$$

Care must be taken to apply this correlation within context. The correlation was derived with ambient temperatures of about 23°C, and it should not be used to predict heat losses at ambient temperatures more or less than 10°C from this value. This limitation is explained further in the report.

UVAC3 heat losses were compared to heat losses from UVAC2, the previous generation of receiver. The UVAC3 receiver shows significantly lower heat loss: 310 vs. 380 W/m at 400°C, which is a 20% reduction in heat loss.

It is important to note that receiver performance depends on more than just heat losses. Optical efficiency testing is required to create a collector/receiver efficiency curve that estimates the heat gain to the heat-transfer fluid flowing within the receiver. Heat losses, as tested in this report, serve to reduce the heat gain to the heat-transfer fluid and therefore reduce the collector/receiver efficiency.

INTRODUCTION

A parabolic trough power plant generates electricity using sunlight as the heat source for its power cycle. Rows of single-axis-tracking, linear parabolic mirrors comprise a solar field that concentrates sunlight onto tubular receivers (also known as heat-collection elements or HCEs) located along the focal line of each parabolic trough. Heat-transfer fluid pumped through the receivers is heated by convection from the sun-heated receiver walls. After being sufficiently heated by the solar field, this hot fluid travels to a power block, where it generates steam in a series of heat exchangers to run a Rankine steam-turbine power cycle. The fluid then returns to the solar field.

Figure 1 shows a section of the solar field of a parabolic trough power plant. This photograph comes from one of the nine Solar Electric Generating Systems (SEGS) built in California's Mojave Desert by Luz International Limited [1]. It illustrates the receivers (HCEs) and parabolic mirrors mounted on a supporting structure, which is collectively referred to as a collector.



Figure 1. Mirrored trough collectors and receivers at a SEGS plant

The SEGS plants currently provide 354 megawatts (MW) to the Southern California Edison utility, and the latest plants operate at fluid temperatures of 293° to 391°C. At these temperatures, the heat losses from the receivers to ambient can significantly affect plant performance by decreasing the amount of heat gained by the internally circulating heat-transfer fluid.

Solel Solar Systems Ltd., based in Israel, manufactures the UVAC3 HCE and the previous-generation UVAC2. This report presents heat-loss test results of two UVAC3 HCEs.

TEST-STAND DESCRIPTION

Figure 2 is a photograph of the National Renewable Energy Laboratory (NREL) HCE Heat-Loss Test Stand. This test stand is located indoors and uses electric resistance heating on the inside of the HCE to bring the absorber surface up to desired test temperatures. Once a desired temperature is reached and the system comes to steady state, power transducers measure the electrical power required to maintain the absorber temperature. The power required is the heat loss of the HCE.



Figure 2. HCE heat-loss test stand at NREL

Present HCEs are 4.06 m long at 25°C (4.08 m at 400°C) with an absorber inner diameter of 6.6 cm. To test HCE heat loss, two copper pipes 2.17 m long and with 5.4 cm outer diameter are inserted into the ends of an HCE—one copper pipe per end. Bolt heads protruding from the copper pipe surface center it in the HCE and prevent it from touching the inner absorber surface. The copper pipe evens out the temperature distribution generated by three internal electric resistance heaters. Two of the heaters are 3-cm-long, stainless-steel-sheathed, coiled cable heaters whose surfaces contact the interior of the copper pipe. We will refer to these heaters as “coil heaters” in this report. The third heater is a 2.12 m (2.01 m heated-length)

inconel cartridge heater suspended along the cylindrical axis of the copper pipe using inconel spacers. The cartridge heater is fully inserted into the copper pipe so that its innermost end, shown in Figure 3, is flush with the innermost end of the copper pipe. The coil heaters are held in position on the cartridge heater by shrink-fitted inconel spacers. When the copper pipe is inserted into the HCE, one coil heater ends up just inside the HCE, whereas the other is adjacent to it but just outside the HCE. The innermost coil heater compensates for end-loss effects, whereas the outermost coil heater is used to create an adiabatic boundary along the copper pipe between the two coil heaters. The cartridge heater supplies most of the thermal input to the system, especially at increasing absorber temperatures. Power transducers measure heater output. The total heat loss is based on the sum of the powers of the two innermost coil heaters and the two cartridge heaters. Figure 3 is a photograph of one of the two heater assemblies, and Table 1 lists heater and power transducer specifications.

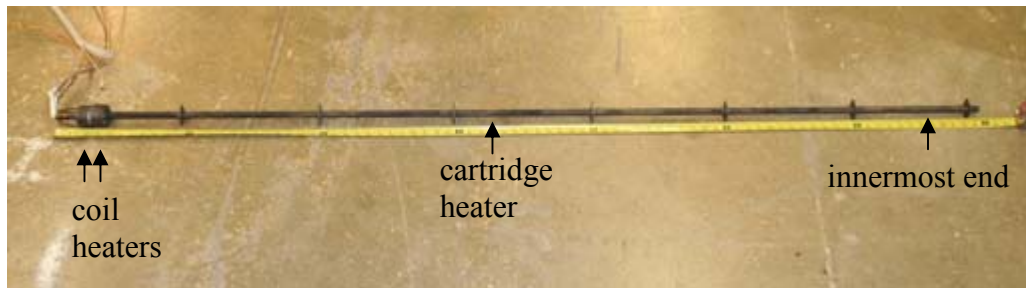

Figure 3. Heater assembly

Table 1. Heater and Power Transducer Specifications

Heater Type	# Used	Max. Power of each Heater (W)	Transducer Full-Scale Limit (W)	Error	
				% of Full Scale	(W)
Coiled cable heater	4	600	500	0.5	2.5
Cartridge heater	2	4800	5000	0.5	25

Thermocouples measure the temperature of the copper pipe, stainless-steel absorber, and glass at the locations shown in Fig. 4. The copper temperature is measured at four locations, the absorber at four locations, and the glass at one location. Figure 4 shows the heating assembly that is responsible for heating one half of the HCE. The heating assembly and thermocouple locations for the other half are identical and symmetrical about the HCE center line, with thermocouple naming conventions continuing from left to right though Cu4 and Abs4. The ends of the copper pipes touch when both heating assemblies are inserted into an HCE.

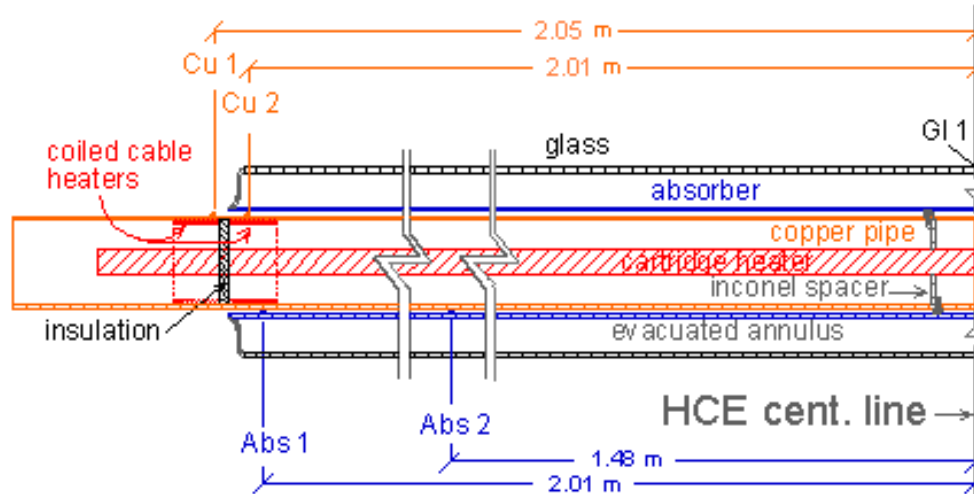

Figure 4. Copper (Cu), absorber (Abs), and glass (Gl) thermocouple locations; absorber at 25°C

Inconel, copper, and stainless steel have different linear expansion coefficients. Care must be taken to attach the copper and inconel at only one point to avoid thermal stresses. The center line of the HCE is the approximate location of this attachment, as shown in Fig. 4. Bolts thread through the copper pipe to rest on either side of an inconel spacer shrink-fitted to the end of the inconel cartridge heater. This is the point from which the inconel cartridge heater, copper pipe, and stainless-steel absorber expand outwards. At 400°C, the outer edge of the absorber overlaps the insulation and almost overlaps the inner edge of the outermost coil heater, whereas thermocouples Abs1, Cu1, and Cu2 become better centered over their respective coil heaters.

Wires attach the thermocouples to the copper and glass surfaces. The thermocouples measuring absorber temperatures spring out from the copper pipe to contact the inner absorber surface. Reliable absorber temperature measurements require good contact between the thermocouple and the absorber, as well as local radiation shielding to prevent radiant heating of the thermocouple by the copper pipe. Figure 5 shows the shielding underneath one thermocouple used to measure absorber temperature, and Table 2 lists the thermocouple specifications. Thermocouples also measure air and heater temperatures.

Testing proceeds once the heating assemblies are in place and the HCE is supported in the test stand. Electrical power to the inner coil and cartridge heaters is increased slowly until all absorber temperatures approach a value of interest (e.g., 400°C). The power to the outer coil heaters is adjusted so that the outer copper temperatures are equal to the inner copper temperatures (i.e., Cu1 = Cu2 and Cu3 = Cu4), creating adiabatic boundaries between Cu1–Cu2 and Cu3–Cu4. Temperatures and power values are logged every 5 seconds. Steady state is achieved when heater set-points are not changed and the center-of-glass and absorber temperatures remain constant (variation $\leq 0.5^\circ\text{C}$) over a period of at least 15 minutes.



Figure 5. Absorber thermocouple with required radiant shielding on copper pipe

Table 2. Thermocouple Specifications

Thermocouple Description	Calibration Type	Range °C	Temperature Error Maximum of:	
			% of Reading	°C
Alloy 600 sheath, mineral insulated, AF metal transition, ungrounded	K – special limits	0–1250	±0.4	±1.1

RESULTS

The heat-loss data for the two UVAC3 HCEs, arbitrarily labeled UVAC3 #1 and UVAC3 #2, are presented in Table 3 and Fig. 6.

Figure 6 shows that the heat-loss results from each UVAC3 are identical within measurement uncertainty. The heat-loss curve fit in Fig. 6 is within the uncertainty bounds of all data points.

NREL has previously tested Solel’s UVAC2 receiver [2]. Figure 7 shows that the UVAC3 receiver has significantly less heat loss than the UVAC2 receiver.

Table 3. UVAC3 Heat-Loss Results

HCE	Test	T _{absorber} (°C)	T _{glass} (°C)	T _{amb.} (°C)	T _{abs.} - T _{amb.} ΔT (°C)	Uncert. in ΔT (±°C)	Heat loss (W/m)	Uncert. in Heat Loss (±W/m)	Date of Test
UVAC3 #1	1	156.3	30.2	22.9	133.3	1.6	29.6	8.9	10/4/07
	2	246.9	40.5	23.0	223.9	1.6	83.0	8.9	10/4/07
	3	309.4	52.6	23.1	286.3	1.7	146.3	9.0	10/9/07
	4	351.2	60.8	22.7	328.5	1.8	207.5	9.1	10/9/07
	5	400.1	73.1	23.1	377.1	1.9	303.1	9.2	10/9/07
	6	201.1	34.0	22.9	178.3	1.6	53.2	8.9	10/16/07
	7	450.2	92.3	24.6	425.6	2.1	454.0	9.4	10/17/07
UVAC3 #2	1	150.5	29.7	23.7	126.8	1.6	30.6	8.9	10/18/07
	2	194.9	34.0	23.8	171.2	1.6	51.1	8.9	10/18/07
	3	249.2	40.8	22.7	226.5	1.6	88.0	9.0	10/19/07
	4	299.8	50.1	22.9	276.9	1.6	140.2	9.1	10/19/07
	5	300.4	48.4	23.5	276.9	1.6	141.2	9.1	10/22/07
	6	349.3	59.7	24.0	325.3	1.8	212.7	9.2	10/22/07
	7	400.2	70.9	23.5	376.7	1.9	319.9	9.3	10/23/07
	8	450.0	87.7	24.2	425.8	2.1	459.3	9.4	10/23/07

UVAC3 Heat Loss Results

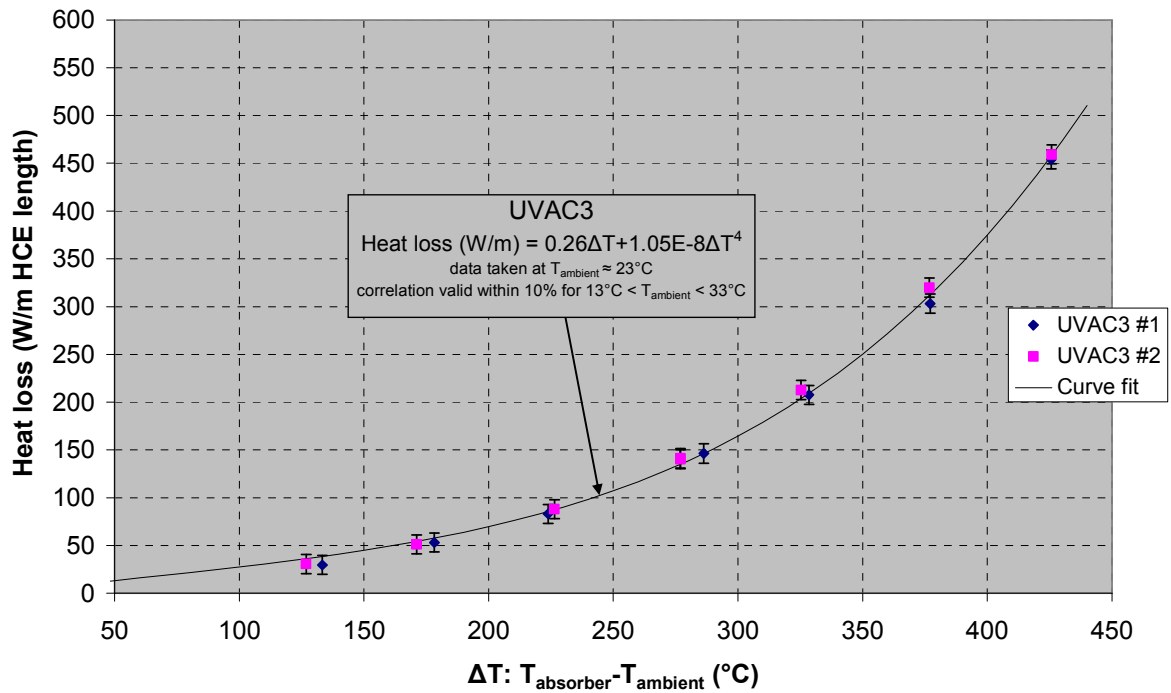

Figure 6. UVAC3 heat-loss results

Comparison of UVAC3 and UVAC2 Heat Loss

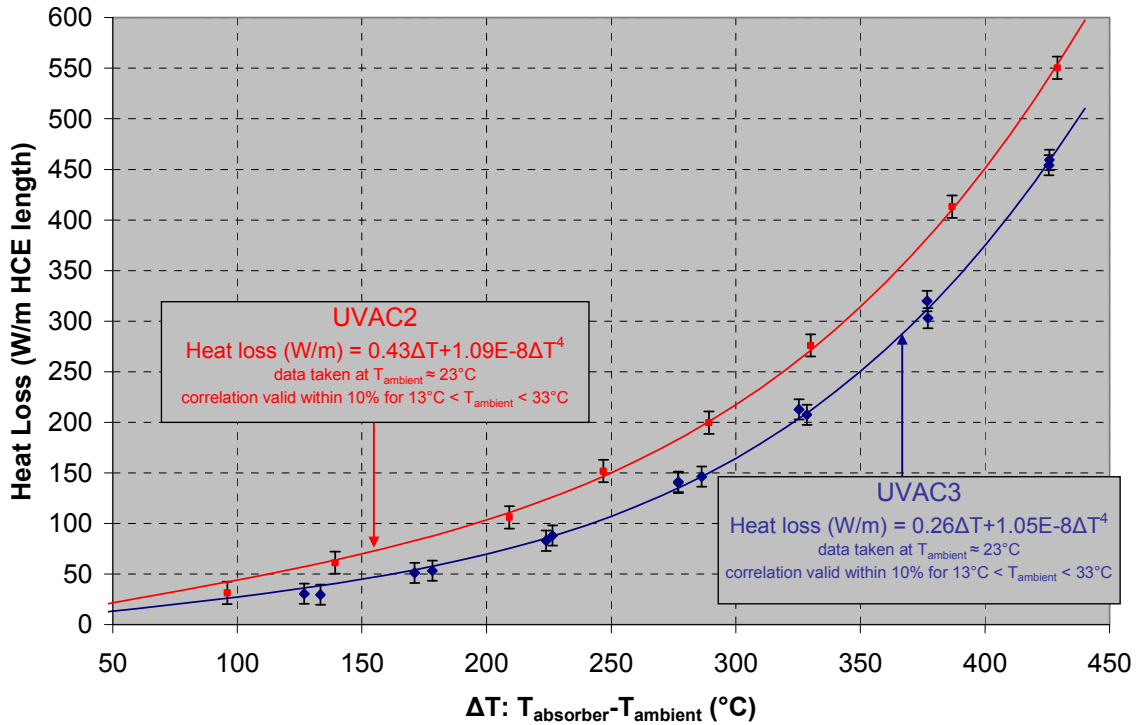

Figure 7. UVAC3 receiver shows less heat loss than UVAC2 receiver

Convention has been to present receiver heat-loss data as a function of the temperature difference between the heat-transfer fluid temperature and ambient temperature [3,4] or the temperature difference between the average absorber temperature and the ambient temperature [2]. Heat losses from evacuated receivers are dominated by radiation heat transfer from the hot absorber surface. For this reason, heat losses from evacuated parabolic trough receivers are better described by the absolute absorber temperature (see Figure 8) than the difference between the absorber or heat-transfer fluid temperature and ambient.

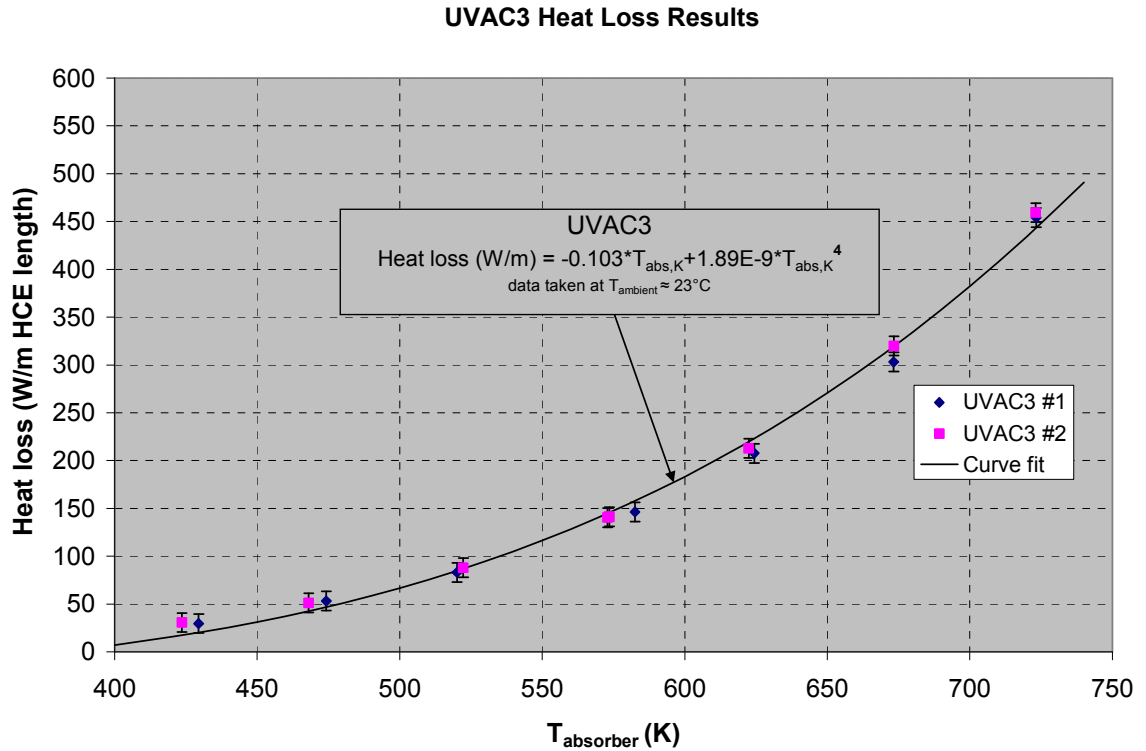

Figure 8. UVAC3 heat loss as a function of absorber temperature

To illustrate how the correlation based on the temperature difference between the absorber and the environment can incorrectly estimate heat loss, consider the following example that uses a validated 1-dimensional heat-transfer model for parabolic trough collector and receiver performance [5]:

A parabolic trough receiver with an absorber spectral emittance curve similar to a UVAC2 receiver is mounted on a collector with a 5 m aperture and operated under direct-normal radiation of 900 W/m^2 at normal incidence to the sun. Therminol VP1 at 380°C is flowing through the receiver's absorber at 140 gallons per minute. If the ambient temperature is 5°C , the model predicts that the average absorber temperature will be 385°C ($\Delta T = 380^\circ\text{C}$) and the heat loss will be 380 W/m . If the ambient temperature is 40°C , the model predicts that the average absorber temperature will be 385°C ($\Delta T = 345^\circ\text{C}$) and the heat loss will be 370 W/m . Even though the ambient temperature, and therefore the ΔT , changed by 35°C in this example, the heat loss changed by only 10 W/m . At a $\Delta T = 380^\circ\text{C}$, the UVAC2 correlation in Fig. 7 shows heat losses that agree with the model prediction of 380 W/m . However, if $\Delta T = 345^\circ\text{C}$ is used in Fig. 7 for the UVAC2 curve, the correlation predicts heat losses of about 310 W/m , not 370 W/m . For this reason, the correlations in the figures should be used with caution—they are most likely accurate to within 10% if they are used with ambient temperatures within 10°C of the temperature at which the data were taken. To predict losses in the solar field, thermal loss coefficients need to be derived from the heat-loss data presented in Table 3. This will be the subject of a future report.

Figures 9 and 10 show the data gathered during one steady-state period to make one data point in Table 3 and Fig. 6. Consider the 400°C absorber steady-state period of Test 5 of UVAC3 #1 in Table 3. Figure 8 shows the absorber temperatures and power use during the test period, whereas Fig. 9 shows the simultaneous glass and air temperatures. “N” and “S” in Fig. 8 refer to the north and south sides of the test stand (the thermocouples are numbered from 1 starting at the north end). In Figs. 8 and 9, all values deviate only slightly during the test period, indicating steady state was reached. The heater powers of Fig. 8 are added and divided by the HCE length to determine heat loss per meter receiver length.

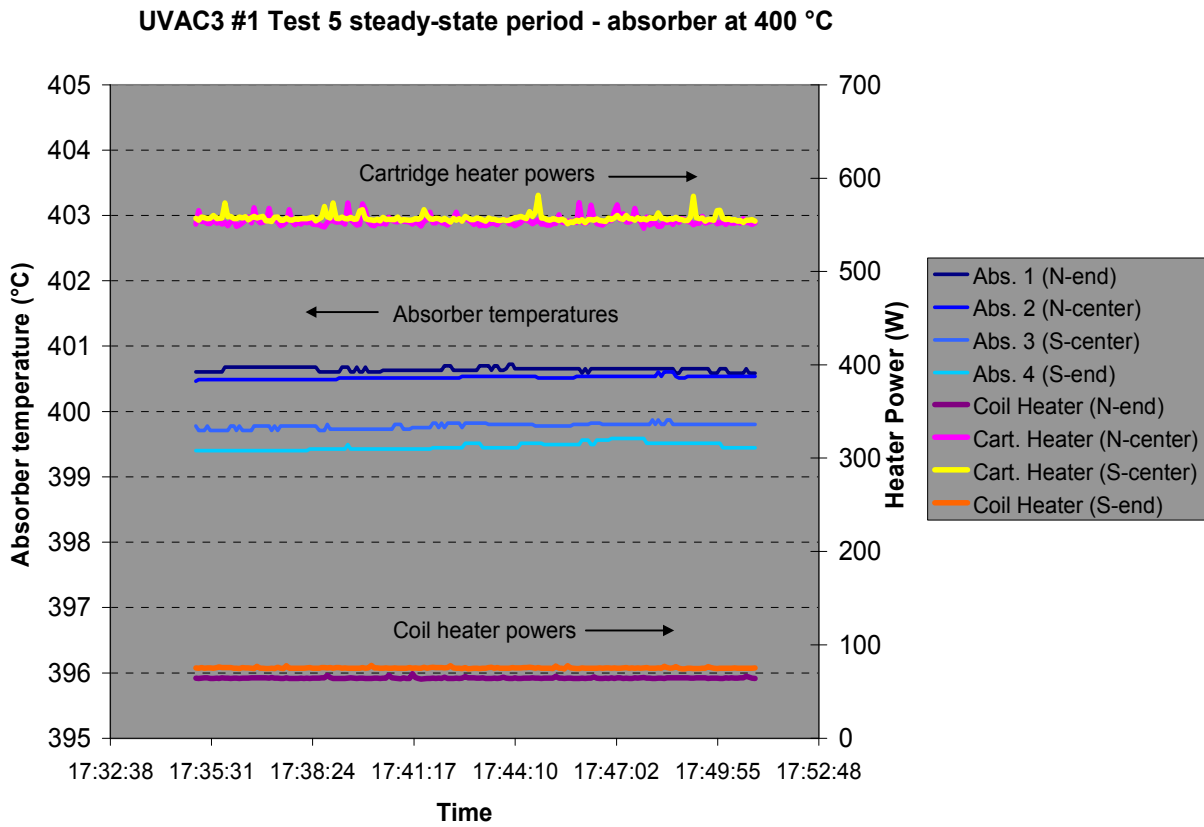

Figure 9. Absorber temperature and power use during Test 5 of UVAC3 #1

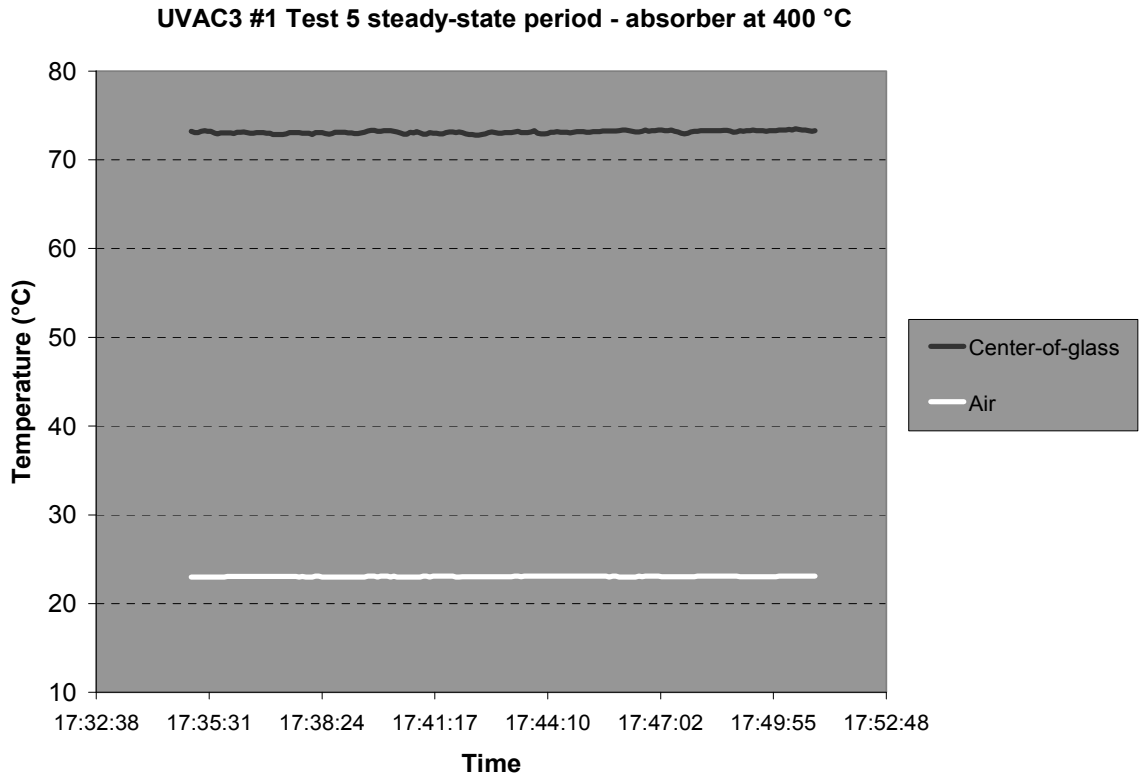

Figure 10. HCE glass and ambient air temperature during Test 5 of UVAC3 #1

UNCERTAINTY ANALYSIS

Measurement uncertainty is quantified using the root sum-of-the-squares method described by Dieck [6]. The general expression for n error sources is

$$(e_R)^2 = \sum_{i=1}^n \left(\frac{\partial R}{\partial e_i} \right)^2 \Delta e_i^2 \quad (1)$$

The receiver heat-loss equation is

$$W_L = H1 + H2 + H3 + H4 + \frac{kA}{\Delta x}(Cu1 - Cu2) + \frac{kA}{\Delta x}(Cu4 - Cu3) \quad (2)$$

where :

W_L is the heat lost (W)

H1 and H4 are coil heater powers

H2 and H3 are cartridge heater powers

k is the conductivity of copper

A is the copper pipe's cross – sectional area

Δx is the length between copper thermocouples

Cu1 – Cu4 are copper thermocouple temps

Note that Cu1 is controlled to equal Cu2, and Cu4 is controlled to equal Cu3, so the contribution due to heat conduction across the end boundary in Eq. (2) is negligible. However, these terms are included in this equation to estimate the uncertainty induced in the results from a potentially non-adiabatic boundary at each end of the HCE.

$$\frac{\partial W_L}{\partial H1} = \frac{\partial W_L}{\partial H2} = \frac{\partial W_L}{\partial H3} = \frac{\partial W_L}{\partial H4} = 1 \quad (3)$$

$$\frac{\partial W_L}{\partial Cu1} = \frac{\partial W_L}{\partial Cu4} = \frac{kA}{\Delta x} \quad (4)$$

$$\frac{\partial W_L}{\partial Cu2} = \frac{\partial W_L}{\partial Cu3} = -\frac{kA}{\Delta x} \quad (5)$$

Zero error has been assumed for the thermal conductivity, cross-sectional area of the copper pipe, and distance between the copper thermocouples.

Substituting (3), (4), and (5) into (1):

$$e_{wL}^2 = \Delta e_{H1}^2 + \Delta e_{H2}^2 + \Delta e_{H3}^2 + \Delta e_{H4}^2 + \left(\frac{kA}{\Delta x}\right)^2 (\Delta Cu1^2 + \Delta Cu2^2 + \Delta Cu3^2 + \Delta Cu4^2) \quad (6)$$

Equation (6) is calculated for bias and precision errors. Consider the following values for a 400°C absorber heat-loss measurement:

$$\begin{aligned} \Delta e_{H1bias} &= \Delta e_{H4bias} = 2.5 \text{ W} \\ \Delta e_{H2bias} &= \Delta e_{H3bias} = 25 \text{ W} \\ \Delta Cu1_{bias} &= \Delta Cu2_{bias} = \Delta Cu3_{bias} = \Delta Cu4_{bias} \approx 1.8 \text{ }^\circ\text{C} \\ k &\approx 380 \frac{\text{W}}{\text{m-K}} \quad A = 3.5 \times 10^{-4} \text{ m}^2 \quad \Delta x = 0.04 \text{ m} \\ \Delta e_{H1prec} &= \Delta e_{H4prec} = 0.04 \text{ W} \\ \Delta e_{H2prec} &= \Delta e_{H3prec} = 0.4 \text{ W} \\ \Delta Cu1_{prec} &= \Delta Cu2_{prec} = \Delta Cu3_{prec} = \Delta Cu4_{prec} \approx 0.005 \text{ }^\circ\text{C} \end{aligned}$$

$$Uncert_{bias}^2 = 2.5^2 + 25^2 + 25^2 + 2.5^2 + \left(\frac{380 * 3.5 \times 10^{-4}}{0.04}\right)^2 (1.8^2 + 1.8^2 + 1.8^2 + 1.8^2) \approx 1400 \text{ W}$$

$$Uncert_{bias} = \sqrt{1400} \approx 37 \text{ W}$$

$$Uncert_{prec}^2 = 0.04^2 + 0.4^2 + 0.4^2 + 0.04^2 + \left(\frac{380 * 3.5 \times 10^{-4}}{0.02}\right)^2 (4 * 0.005^2) \approx 0.1 \text{ W}$$

$$Uncert_{prec} = \sqrt{0.33} = 0.6 \text{ W}$$

$$Uncert_{total} = \pm \sqrt{(Uncert_{bias}^2 + (2 * Uncert_{prec}^2))} = \pm 37 \text{ W}$$

Normalizing per meter length:

$$Uncert_{Total} = \left(\frac{37 W}{4 m} \right) \approx \pm 9 \frac{W}{m}$$

CONCLUSION

NREL has completed heat-loss testing on two of Solel's UVAC3 parabolic trough receivers. The receivers showed identical heat losses within experimental uncertainty. Normalized per meter of receiver length, the heat losses are 130, 200, 310, and 460 W/m at average absorber temperatures of 300°, 350°, 400°, and 450°C, respectively. Experimental uncertainty is about ±10 W/m. A correlation was developed to predict receiver heat loss as a function of the difference in °C between the average absorber temperature and ambient temperature. This correlation is:

$$\text{UVAC3 heat loss (W/m)} = 0.26 * \Delta T + 1.05 * 10^{-8} * \Delta T^4$$

This correlation will be accurate within 10% for ambient temperatures between 13° and 33°C. UVAC3 heat losses were also compared to previous-generation UVAC2 heat losses. The UVAC3 receiver shows significantly lower heat loss: 310 vs. 380 W/m at 400°C, which is a 20% reduction in heat loss.

Receiver performance depends on more than just heat losses. Optical-efficiency testing is required to create a collector/receiver efficiency curve that estimates the heat gain to the heat-transfer fluid flowing within the receiver. Heat losses, as tested in this report, serve to reduce the heat gain to the heat-transfer fluid and thereby decrease collector/receiver efficiency. Determination of loss coefficients to predict solar field performance will be the subject of a future report.

ACKNOWLEDGMENTS

The authors would like to acknowledge Hank Price, formerly with the National Renewable Energy Laboratory (NREL) and now with Solucar; Judy Netter and Calvin Feik from NREL; and Tim Moss at Sandia National Laboratories for assistance with the design and construction of the test stand.

REFERENCES

- [1] Kearney, D.; Price, H., "Advances in Parabolic Trough Solar Power Technology," *Advances in Solar Energy*. Vol 16, Kreith, F., Goswami, D.Y. (Eds.), ASES, Boulder, Colorado, 2005.
- [2] Burkholder, F.; Price, H.; Kutscher, C.; Brandemuehl, M.; Netter, J., "Parabolic Trough Receiver Thermal Testing," Proceedings of the ASME Energy Sustainability Conference, Long Beach, California, June 27–30, 2007.
- [3] Dudley, V.; Kolb, G.; Mahoney, A.R.; Mancini, T.; Matthews, C.; Sloan, M.; Kearney, D., "Test Results SEGS LS-2 Solar Collector," SAND94-1884, December 1994.
- [4] Moss, T.; Brousseau, D., "Test Results of a Schott Trough Receiver using a LS-2 Collector," Proceedings of ISEC: ASME 2005, Orlando, Florida, August 6–12, 2005
- [5] Forristall, R., "EES Heat Transfer Model for Solar Receiver Performance," Proceedings of ISEC, Solar 2004, Portland, Oregon, July 11–14, 2004.
- [6] Dieck, R.H., *Measurement Uncertainty, Methods and Applications*. North Carolina: Instrument Society of America, 1992

REPORT DOCUMENTATION PAGE

Form Approved
OMB No. 0704-0188

The public reporting burden for this collection of information is estimated to average 1 hour per response, including the time for reviewing instructions, searching existing data sources, gathering and maintaining the data needed, and completing and reviewing the collection of information. Send comments regarding this burden estimate or any other aspect of this collection of information, including suggestions for reducing the burden, to Department of Defense, Executive Services and Communications Directorate (0704-0188). Respondents should be aware that notwithstanding any other provision of law, no person shall be subject to any penalty for failing to comply with a collection of information if it does not display a currently valid OMB control number.

PLEASE DO NOT RETURN YOUR FORM TO THE ABOVE ORGANIZATION.

1. REPORT DATE (DD-MM-YYYY) January 2008		2. REPORT TYPE Technical report		3. DATES COVERED (From - To)	
4. TITLE AND SUBTITLE Heat-Loss Testing of Solel's UVAC3 Parabolic Trough Receiver			5a. CONTRACT NUMBER DE-AC36-99-GO10337		
			5b. GRANT NUMBER		
			5c. PROGRAM ELEMENT NUMBER		
6. AUTHOR(S) F. Burkholder and C. Kutscher			5d. PROJECT NUMBER NREL/TP-550-42394		
			5e. TASK NUMBER CP07.3101		
			5f. WORK UNIT NUMBER		
7. PERFORMING ORGANIZATION NAME(S) AND ADDRESS(ES) National Renewable Energy Laboratory 1617 Cole Blvd. Golden, CO 80401-3393				8. PERFORMING ORGANIZATION REPORT NUMBER NREL/TP-550-42394	
9. SPONSORING/MONITORING AGENCY NAME(S) AND ADDRESS(ES)				10. SPONSOR/MONITOR'S ACRONYM(S) NREL	
				11. SPONSORING/MONITORING AGENCY REPORT NUMBER	
12. DISTRIBUTION AVAILABILITY STATEMENT National Technical Information Service U.S. Department of Commerce 5285 Port Royal Road Springfield, VA 22161					
13. SUPPLEMENTARY NOTES					
14. ABSTRACT (Maximum 200 Words) NREL researchers completed heat-loss testing on two of Solel's UVAC3 parabolic trough receivers. The receivers showed identical heat losses within experimental uncertainty. Normalized per meter of receiver length, heat losses are about 130, 200, 310, and 460 W/m at average absorber temperatures of 300°, 350°, 400°, and 450°C, respectively. Experimental uncertainty is about ±10 W/m. We developed a correlation to predict receiver heat loss as a function of the difference in °C between the average absorber temperature and ambient temperature. This correlation is the following: UVAC3 heat loss (W/m) = 0.26 * ΔT + 1.05 * 10 ⁻⁸ * ΔT ⁴ . Care must be taken to apply this correlation only within context. The correlation was derived with ambient temperatures of about 23°C, and it should not be used to predict heat losses at ambient temperatures more or less than 10°C from this value. UVAC3 heat losses were compared to heat losses from UVAC2, the previous generation of receiver. The UVAC3 receiver shows significantly lower heat loss: 310 vs. 380 W/m at 400°C, which is a 20% reduction in heat loss. It is important to note that receiver performance depends on more than just heat losses. Optical efficiency testing is required to create a collector/receiver efficiency curve that estimates the heat gain to the heat-transfer fluid flowing within the receiver. Heat losses, as tested in this report, serve to reduce the heat gain to the heat-transfer fluid and therefore reduce the collector/receiver efficiency.					
15. SUBJECT TERMS CSP ; parabolic trough ; receiver ; heat-loss testing ; correlation ; UVAC3					
16. SECURITY CLASSIFICATION OF:			17. LIMITATION OF ABSTRACT UL	18. NUMBER OF PAGES	19a. NAME OF RESPONSIBLE PERSON
a. REPORT Unclassified	b. ABSTRACT Unclassified	c. THIS PAGE Unclassified			19b. TELEPHONE NUMBER (Include area code)