Severe Accident Risks: An Assessment for Five U.S. Nuclear Power Plants

Final Summary Report

U.S. Nuclear Regulatory Commission

Office of Nuclear Regulatory Research



AVAILABILITY NOTICE

Availability of Reference Materials Cited in NRC Publications

Most documents cited in NRC publications will be available from one of the following sources:

1. The NRC Public Document Room, 2120 L Street, NW, Lower Level, Washington, DC 20555
2. The Superintendent of Documents, U.S. Government Printing Office, P.O. Box 37082, Washington, DC 20013-7082
3. The National Technical Information Service, Springfield, VA 22161

Although the listing that follows represents the majority of documents cited in NRC publications, it is not intended to be exhaustive.

Referenced documents available for inspection and copying for a fee from the NRC Public Document Room include NRC correspondence and internal NRC memoranda; NRC Office of Inspection and Enforcement bulletins, circulars, information notices, inspection and investigation notices; Licensee Event Reports; vendor reports and correspondence; Commission papers; and applicant and licensee documents and correspondence.

The following documents in the NUREG series are available for purchase from the GPO Sales Program: formal NRC staff and contractor reports, NRC-sponsored conference proceedings, and NRC booklets and brochures. Also available are Regulatory Guides, NRC regulations in the Code of Federal Regulations, and Nuclear Regulatory Commission Issuances.

Documents available from the National Technical Information Service include NUREG series reports and technical reports prepared by other federal agencies and reports prepared by the Atomic Energy Commission, forerunner agency to the Nuclear Regulatory Commission.

Documents available from public and special technical libraries include all open literature items, such as books, journal and periodical articles, and transactions. Federal Register notices, federal and state legislation, and congressional reports can usually be obtained from these libraries.

Documents such as theses, dissertations, foreign reports and translations, and non-NRC conference proceedings are available for purchase from the organization sponsoring the publication cited.

Single copies of NRC draft reports are available free, to the extent of supply, upon written request to the Office of Information Resources Management, Distribution Section, U.S. Nuclear Regulatory Commission, Washington, DC 20555.

Copies of industry codes and standards used in a substantive manner in the NRC regulatory process are maintained at the NRC Library, 7920 Norfolk Avenue, Bethesda, Maryland, and are available there for reference use by the public. Codes and standards are usually copyrighted and may be purchased from the originating organization or, if they are American National Standards, from the American National Standards Institute, 1430 Broadway, New York, NY 10018.

Severe Accident Risks: An Assessment for Five U.S. Nuclear Power Plants

Final Summary Report

Manuscript Completed: October 1990
Date Published: December 1990

**Division of Systems Research
Office of Nuclear Regulatory Research
U.S. Nuclear Regulatory Commission
Washington, DC 20555**



ABSTRACT

This report summarizes an assessment of the risks from severe accidents in five commercial nuclear power plants in the United States. These risks are measured in a number of ways, including: the estimated frequencies of core damage accidents from internally initiated accidents and externally initiated accidents for two of the plants; the performance of containment structures under severe accident loadings; the potential magnitude of radionuclide releases and offsite consequences of such accidents; and the overall risk (the product of accident frequencies and consequences). Supporting this summary report are a large number of reports written under contract to NRC that provide the detailed discussion of the methods used and results obtained in these risk studies.

This report was first published in February 1987 as a draft for public comment. Extensive peer review and public comment were received. As a result, both the underlying technical analyses and the report itself were substantially changed. A

second version of the report was published in June 1989 as a draft for peer review. Two peer reviews of the second version were performed. One was sponsored by NRC; its results are published as the NRC report NUREG-1420. A second was sponsored by the American Nuclear Society (ANS); its report has also been completed and is available from the ANS. The comments by both groups were generally positive and recommended that a final version of the report be published as soon as practical and without performing any major reanalysis. With this direction, the NRC proceeded to generate this final version of the report.

Volume 1 of this report has three parts. Part I provides the background and objectives of the assessment and summarizes the methods used to perform the risk studies. Part II provides a summary of results obtained for each of the five plants studied. Part III provides perspectives on the results and discusses the role of this work in the larger context of the NRC staff's work.

CONTENTS

| | <i>Page</i> |
|---|-------------|
| Abstract | iii |
| Acknowledgments | xv |
| PART I INTRODUCTION AND SUMMARY OF METHODS | |
| 1. INTRODUCTION | 1-1 |
| 1.1 Background | 1-1 |
| 1.2 Objectives | 1-2 |
| 1.3 Scope of Risk Analyses | 1-3 |
| 1.4 Structure of NUREG-1150 and Supporting Documents | 1-4 |
| 2. SUMMARY OF METHODS | 2-1 |
| 2.1 Introduction | 2-1 |
| 2.2 Accident Frequency Estimation | 2-4 |
| 2.2.1 Methods | 2-4 |
| 2.2.2 Products of Accident Frequency Analysis | 2-8 |
| 2.3 Accident Progression, Containment Loading, and Structural Response Analysis | 2-11 |
| 2.3.1 Methods | 2-11 |
| 2.3.2 Products of Accident Progression, Containment Loading, and Structural Response Analysis | 2-13 |
| 2.4 Analysis of Radioactive Material Transport | 2-16 |
| 2.4.1 Methods | 2-16 |
| 2.4.2 Products of Radioactive Material Transport Analysis | 2-17 |
| 2.5 Offsite Consequence Analysis | 2-18 |
| 2.5.1 Methods | 2-18 |
| 2.5.2 Products of Offsite Consequence Analysis | 2-20 |
| 2.6 Uncertainty Analysis | 2-21 |
| 2.7 Formal Procedures for Elicitation of Expert Judgment | 2-23 |
| 2.8 Risk Integration | 2-26 |
| 2.8.1 Methods | 2-26 |
| 2.8.2 Products of Risk Integration | 2-26 |
| PART II SUMMARY OF PLANT RESULTS | |
| 3. SURRY PLANT RESULTS | 3-1 |
| 3.1 Summary Design Information | 3-1 |
| 3.2 Core Damage Frequency Estimates | 3-1 |
| 3.2.1 Summary of Core Damage Frequency Estimates | 3-1 |
| 3.2.2 Important Plant Characteristics (Core Damage Frequency) | 3-8 |
| 3.2.3 Important Operator Actions | 3-9 |
| 3.2.4 Important Individual Events and Uncertainties (Core Damage Frequency) | 3-10 |

| | <i>Page</i> |
|---|-------------|
| 3.3 Containment Performance Analysis | 3-10 |
| 3.3.1 Results of Containment Performance Analysis | 3-10 |
| 3.3.2 Important Plant Characteristics (Containment Performance) | 3-11 |
| 3.4 Source Term Analysis | 3-14 |
| 3.4.1 Results of Source Term Analysis | 3-14 |
| 3.4.2 Important Plant Characteristics (Source Term) | 3-14 |
| 3.5 Offsite Consequence Results | 3-17 |
| 3.6 Public Risk Estimates | 3-17 |
| 3.6.1 Results of Public Risk Estimates | 3-17 |
| 3.6.2 Important Plant Characteristics (Risk) | 3-20 |
| 4. PEACH BOTTOM PLANT RESULTS | 4-1 |
| 4.1 Summary Design Information | 4-1 |
| 4.2 Core Damage Frequency Estimates | 4-1 |
| 4.2.1 Summary of Core Damage Frequency Estimates | 4-1 |
| 4.2.2 Important Plant Characteristics (Core Damage Frequency) | 4-7 |
| 4.2.3 Important Operator Actions | 4-9 |
| 4.2.4 Important Individual Events and Uncertainties (Core Damage Frequency) | 4-11 |
| 4.3 Containment Performance Analysis | 4-11 |
| 4.3.1 Results of Containment Performance Analysis | 4-11 |
| 4.3.2 Important Plant Characteristics (Containment Performance) | 4-12 |
| 4.4 Source Term Analysis | 4-15 |
| 4.4.1 Results of Source Term Analysis | 4-15 |
| 4.4.2 Important Plant Characteristics (Source Term) | 4-15 |
| 4.5 Offsite Consequence Results | 4-18 |
| 4.6 Public Risk Estimates | 4-18 |
| 4.6.1 Results of Public Risk Estimates | 4-18 |
| 4.6.2 Important Plant Characteristics (Risk) | 4-21 |
| 5. SEQUOYAH PLANT RESULTS | 5-1 |
| 5.1 Summary Design Information | 5-1 |
| 5.2 Core Damage Frequency Estimates | 5-1 |
| 5.2.1 Summary of Core Damage Frequency Estimates | 5-1 |
| 5.2.2 Important Plant Characteristics (Core Damage Frequency) | 5-6 |
| 5.2.3 Important Operator Actions | 5-7 |
| 5.2.4 Important Individual Events and Uncertainties (Core Damage Frequency) | 5-8 |
| 5.3 Containment Performance Analysis | 5-9 |
| 5.3.1 Results of Containment Performance Analysis | 5-9 |
| 5.3.2 Important Plant Characteristics (Containment Performance) | 5-9 |

| | <i>Page</i> |
|---|-------------|
| 5.4 Source Term Analysis | 5-12 |
| 5.4.1 Results of Source Term Analysis | 5-12 |
| 5.4.2 Important Plant Characteristics (Source Term) | 5-12 |
| 5.5 Offsite Consequence Results | 5-15 |
| 5.6 Public Risk Estimates | 5-15 |
| 5.6.1 Results of Public Risk Estimates | 5-15 |
| 5.6.2 Important Plant Characteristics (Risk) | 5-20 |
| 6. GRAND GULF PLANT RESULTS | 6-1 |
| 6.1 Summary Design Information | 6-1 |
| 6.2 Core Damage Frequency Estimates | 6-1 |
| 6.2.1 Summary of Core Damage Frequency Estimates | 6-1 |
| 6.2.2 Important Plant Characteristics (Core Damage Frequency) | 6-3 |
| 6.2.3 Important Operator Actions | 6-7 |
| 6.2.4 Important Individual Events and Uncertainties (Core Damage Frequency) | 6-9 |
| 6.3 Containment Performance Analysis | 6-9 |
| 6.3.1 Results of Containment Performance Analysis | 6-9 |
| 6.3.2 Important Plant Characteristics (Containment Performance) | 6-10 |
| 6.4 Source Term Analysis | 6-13 |
| 6.4.1 Results of Source Term Analysis | 6-13 |
| 6.4.2 Important Plant Characteristics (Source Term) | 6-13 |
| 6.5 Offsite Consequence Results | 6-13 |
| 6.6 Public Risk Estimates | 6-17 |
| 6.6.1 Results of Public Risk Estimates | 6-17 |
| 6.6.2 Important Plant Characteristics (Risk) | 6-17 |
| 7. ZION PLANT RESULTS | 7-1 |
| 7.1 Summary Design Information | 7-1 |
| 7.2 Core Damage Frequency Estimates | 7-1 |
| 7.2.1 Summary of Core Damage Frequency Estimates | 7-1 |
| 7.2.2 Important Plant Characteristics (Core Damage Frequency) | 7-4 |
| 7.2.3 Important Operator Actions | 7-6 |
| 7.3 Containment Performance Analysis | 7-6 |
| 7.3.1 Results of Containment Performance Analysis | 7-6 |
| 7.3.2 Important Plant Characteristics (Containment Performance) | 7-9 |
| 7.4 Source Term Analysis | 7-9 |
| 7.4.1 Results of Source Term Analysis | 7-9 |
| 7.4.2 Important Plant Characteristics (Source Term) | 7-9 |
| 7.5 Offsite Consequence Results | 7-12 |

| | | |
|---------------------------------------|---|------|
| 7.6 | Public Risk Estimates | 7-12 |
| 7.6.1 | Results of Public Risk Estimates | 7-12 |
| 7.6.2 | Important Plant Characteristics (Risk) | 7-18 |
| PART III PERSPECTIVES AND USES | | |
| 8. | PERSPECTIVES ON FREQUENCY OF CORE DAMAGE | 8-1 |
| 8.1 | Introduction | 8-1 |
| 8.2 | Summary of Results | 8-1 |
| 8.3 | Comparison with Reactor Safety Study | 8-1 |
| 8.4 | Perspectives | 8-10 |
| 8.4.1 | Internal-Event Core Damage Probability Distributions | 8-10 |
| 8.4.2 | Principal Contributors to Uncertainty in Core Damage Frequency | 8-11 |
| 8.4.3 | Dominant Accident Sequence Types | 8-11 |
| 8.4.4 | External Events | 8-15 |
| 9. | PERSPECTIVES ON ACCIDENT PROGRESSION AND CONTAINMENT PERFORMANCE ... | 9-1 |
| 9.1 | Introduction | 9-1 |
| 9.2 | Summary of Results | 9-1 |
| 9.2.1 | Internal Events | 9-2 |
| 9.2.2 | External Events | 9-5 |
| 9.2.3 | Additional Summary Results | 9-9 |
| 9.3 | Comparison with Reactor Safety Study | 9-10 |
| 9.4 | Perspectives | 9-13 |
| 9.4.1 | State of Analysis Methods | 9-13 |
| 9.4.2 | Important Mechanisms That Defeat Containment Function During Severe Accidents . | 9-14 |
| 9.4.3 | Major Sources of Uncertainty | 9-17 |
| 10. | PERSPECTIVES ON SEVERE ACCIDENT SOURCE TERMS | 10-1 |
| 10.1 | Introduction | 10-1 |
| 10.2 | Summary of Results | 10-1 |
| 10.3 | Comparison with Reactor Safety Study | 10-4 |
| 10.4 | Perspectives | 10-6 |
| 10.4.1 | State of Methods | 10-6 |
| 10.4.2 | Important Design Features | 10-6 |
| 10.4.3 | Important Phenomenological Uncertainties | 10-9 |
| 11. | PERSPECTIVES ON OFFSITE CONSEQUENCES | 11-1 |
| 11.1 | Introduction | 11-1 |
| 11.2 | Discussion of Consequence CCDFs | 11-1 |
| 11.3 | Discussion, Summary, and Interplant Comparison of Offsite Consequence Results | 11-1 |
| 11.4 | Comparison with Reactor Safety Study | 11-8 |
| 11.5 | Uncertainties and Sensitivities | 11-9 |

| | <i>Page</i> |
|---|-------------|
| 11.6 Sensitivity of Consequence Measure CCDFs to Protective Measure Assumptions | 11-9 |
| 11.6.1 Sensitivity of Early Fatality CCDFs to Emergency Response | 11-9 |
| 11.6.2 Sensitivity of Latent Cancer Fatality and Population Exposure CCDFs to Radiological Protective Action Guide (PAG) Levels for Long-Term Countermeasures | 11-12 |
| 12. PERSPECTIVES ON PUBLIC RISK | 12-1 |
| 12.1 Introduction | 12-1 |
| 12.2 Summary of Results | 12-1 |
| 12.3 Comparison with Reactor Safety Study | 12-7 |
| 12.4 Perspectives | 12-7 |
| 13. NUREG-1150 AS A RESOURCE DOCUMENT | 13-1 |
| 13.1 Introduction | 13-1 |
| 13.2 Probabilistic Models of Accident Sequences | 13-1 |
| 13.2.1 Guidance for Individual Plant Examinations | 13-1 |
| 13.2.2 Guidance for Accident Management Strategies | 13-3 |
| 13.2.3 Improving Containment Performance | 13-6 |
| 13.2.4 Determining Important Plant Operational Features | 13-6 |
| 13.2.5 Alternative Safety Goal Implementation Strategies | 13-7 |
| 13.2.6 Effect of Emergency Preparedness on Consequence Estimates | 13-7 |
| 13.3 Major Factors Contributing to Risk | 13-11 |
| 13.3.1 Reactor Research | 13-14 |
| 13.3.2 Prioritization of Generic Issues | 13-14 |
| 13.3.3 Use of PRA in Inspections | 13-14 |

FIGURES

| | |
|--|------|
| 1.1 Reports supporting NUREG-1150. | 1-6 |
| 2.1 Elements of risk analysis process | 2-2 |
| 2.2 Example display of core damage frequency distribution. | 2-10 |
| 2.3 Example display of mean plant damage state frequencies. | 2-11 |
| 2.4 Example display of mean accident progression bin conditional probabilities. | 2-14 |
| 2.5 Example display of early containment failure probability distribution. | 2-15 |
| 2.6 Example display of radioactive release distributions. | 2-18 |
| 2.7 Example display of source term complementary cumulative distribution function. | 2-19 |
| 2.8 Example display of offsite consequences complementary cumulative distribution function | 2-22 |
| 2.9 Principal steps in expert elicitation process. | 2-24 |
| 2.10 Example display of relative contributions to mean risk. | 2-27 |
| 3.1 Surry plant schematic | 3-3 |
| 3.2 Internal core damage frequency results at Surry. | 3-4 |

| | | |
|------|---|------|
| 3.3 | Contributors to mean core damage frequency from internal events at Surry. | 3-5 |
| 3.4 | Contributors to mean core damage frequency from external events (LLNL hazard curve) at Surry. | 3-7 |
| 3.5 | Conditional probability of accident progression bins at Surry. | 3-12 |
| 3.6 | Conditional probability distributions for early containment failure at Surry. | 3-13 |
| 3.7 | Source term distributions for containment bypass at Surry. | 3-15 |
| 3.8 | Source term distributions for late containment failure at Surry. | 3-16 |
| 3.9 | Frequency distributions of offsite consequence measures at Surry (internal initiators). | 3-18 |
| 3.10 | Frequency distributions of offsite consequence measures at Surry (fire initiators). | 3-19 |
| 3.11 | Early and latent cancer fatality risks at Surry (internal initiators). | 3-21 |
| 3.12 | Population dose risks at Surry (internal initiators). | 3-22 |
| 3.13 | Individual early and latent cancer fatality risks at Surry (internal initiators). | 3-23 |
| 3.14 | Major contributors (plant damage states) to mean early and latent cancer fatality risks at Surry (internal initiators). | 3-24 |
| 3.15 | Major contributors (accident progression bins) to mean early and latent cancer fatality risks at Surry (internal initiators). | 3-24 |
| 3.16 | Early and latent cancer fatality risks at Surry (fire initiators). | 3-25 |
| 3.17 | Population dose risks at Surry (fire initiators). | 3-26 |
| 3.18 | Individual early and latent cancer fatality risks at Surry (fire initiators). | 3-27 |
| 3.19 | Major contributors (accident progression bins) to mean early and latent cancer fatality risks at Surry (fire initiators). | 3-28 |
| 4.1 | Peach Bottom plant schematic. | 4-3 |
| 4.2 | Internal core damage frequency results at Peach Bottom. | 4-4 |
| 4.3 | Contributors to mean core damage frequency from internal events at Peach Bottom. | 4-5 |
| 4.4 | Contributors to mean core damage frequency from external events (LLNL hazard curve) at Peach Bottom. | 4-7 |
| 4.5 | Conditional probability of accident progression bins at Peach Bottom. | 4-13 |
| 4.6 | Conditional probability distributions for early containment failure at Peach Bottom. | 4-14 |
| 4.7 | Source term distributions for early failure in drywell at Peach Bottom. | 4-16 |
| 4.8 | Source term distributions for vented containment at Peach Bottom. | 4-17 |
| 4.9 | Frequency distributions of offsite consequence measures at Peach Bottom (internal initiators). | 4-19 |
| 4.10 | Frequency distributions of offsite consequence measures at Peach Bottom (fire initiators). ... | 4-20 |
| 4.11 | Early and latent cancer fatality risks at Peach Bottom (internal initiators). | 4-22 |
| 4.12 | Population dose risks at Peach Bottom (internal initiators). | 4-23 |
| 4.13 | Individual early and latent cancer fatality risks at Peach Bottom (internal initiators). | 4-24 |
| 4.14 | Major contributors (plant damage states) to mean early and latent cancer fatality risks at Peach Bottom (internal initiators). | 4-25 |
| 4.15 | Major contributors (accident progression bins) to mean early and latent cancer fatality risks at Peach Bottom (internal initiators). | 4-25 |
| 4.16 | Early and latent cancer fatality risks at Peach Bottom (fire initiators). | 4-26 |
| 4.17 | Population dose risks at Peach Bottom (fire initiators). | 4-27 |
| 4.18 | Individual early and latent cancer fatality risks at Peach Bottom (fire initiators). | 4-28 |
| 4.19 | Major contributors (accident progression bins) to mean early and latent cancer fatality risks at Peach Bottom (fire initiators). | 4-29 |

| | | |
|------|---|------|
| 5.1 | Sequoyah plant schematic. | 5-3 |
| 5.2 | Internal core damage frequency results at Sequoyah. | 5-4 |
| 5.3 | Contributors to mean core damage frequency from internal events at Sequoyah | 5-5 |
| 5.4 | Conditional probability of accident progression bins at Sequoyah. | 5-10 |
| 5.5 | Conditional probability distributions for early containment failure at Sequoyah. | 5-11 |
| 5.6 | Source term distributions for early containment failure at Sequoyah. | 5-13 |
| 5.7 | Source term distributions for late containment failure at Sequoyah. | 5-14 |
| 5.8 | Frequency distributions of offsite consequence measures at Sequoyah (internal initiators). | 5-16 |
| 5.9 | Early and latent cancer fatality risks at Sequoyah (internal initiators). | 5-17 |
| 5.10 | Population dose risks at Sequoyah (internal initiators). | 5-18 |
| 5.11 | Individual early and latent cancer fatality risks at Sequoyah (internal initiators). | 5-19 |
| 5.12 | Major contributors (plant damage states) to mean early and latent cancer fatality risks at Sequoyah (internal initiators). | 5-21 |
| 5.13 | Major contributors (accident progression bins) to mean early and latent cancer fatality risks at Sequoyah (internal initiators). | 5-21 |
| 6.1 | Grand Gulf plant schematic. | 6-4 |
| 6.2 | Internal core damage frequency results at Grand Gulf. | 6-5 |
| 6.3 | Contributors to mean core damage frequency from internal events at Grand Gulf. | 6-6 |
| 6.4 | Conditional probability of accident progression bins at Grand Gulf. | 6-11 |
| 6.5 | Conditional probability distributions for early containment failure at Grand Gulf. | 6-12 |
| 6.6 | Source term distributions for early containment failure with drywell failed and sprays unavailable at Grand Gulf. | 6-14 |
| 6.7 | Source term distributions for early containment failure with drywell intact at Grand Gulf. | 6-15 |
| 6.8 | Frequency distributions of offsite consequence measures at Grand Gulf (internal initiators). ... | 6-16 |
| 6.9 | Early and latent cancer fatality risks at Grand Gulf (internal initiators). | 6-18 |
| 6.10 | Population dose risks at Grand Gulf (internal initiators). | 6-19 |
| 6.11 | Individual early and latent cancer fatality risks at Grand Gulf (internal initiators). | 6-20 |
| 6.12 | Major contributors (plant damage states) to mean early and latent cancer fatality risks at Grand Gulf (internal initiators). | 6-21 |
| 6.13 | Major contributors (accident progression bins) to mean early and latent cancer fatality risks at Grand Gulf (internal initiators). | 6-21 |
| 7.1 | Zion plant schematic. | 7-3 |
| 7.2 | Contributors to mean core damage frequency from internal events at Zion. | 7-5 |
| 7.3 | Conditional probability of accident progression bins at Zion. | 7-7 |
| 7.4 | Conditional probability distributions for early containment failure at Zion. | 7-8 |
| 7.5 | Source term distributions for early containment failure at Zion. | 7-10 |
| 7.6 | Source term distributions for no containment failure at Zion. | 7-11 |
| 7.7 | Frequency distributions of offsite consequence measures at Zion (internal initiators). | 7-13 |
| 7.8 | Early and latent cancer fatality risks at Zion (internal initiators). | 7-14 |
| 7.9 | Population dose risks at Zion (internal initiators). | 7-15 |
| 7.10 | Individual early and latent cancer fatality risks at Zion (internal initiators). | 7-16 |
| 7.11 | Major contributors (plant damage states) to mean early and latent cancer fatality risks at Zion (internal initiators). | 7-17 |
| 7.12 | Major contributors (accident progression bins) to mean early and latent cancer fatality risks at Zion (internal initiators). | 7-17 |

| | | |
|-------|--|-------|
| 8.1 | Internal core damage frequency ranges (5th to 95th percentiles). | 8-2 |
| 8.2 | BWR principal contributors to internal core damage frequencies. | 8-3 |
| 8.3 | PWR principal contributors to internal core damage frequencies. | 8-3 |
| 8.4 | Principal contributors to internal core damage frequencies. | 8-4 |
| 8.5 | Surry external-event core damage frequency distributions. | 8-5 |
| 8.6 | Peach Bottom external-event core damage frequency distributions. | 8-5 |
| 8.7 | Surry internal- and external-event core damage frequency ranges. | 8-6 |
| 8.8 | Peach Bottom internal- and external-event core damage frequency ranges. | 8-6 |
| 8.9 | Principal contributors to seismic core damage frequencies. | 8-7 |
| 8.10 | Principal contributors to fire core damage frequencies. | 8-7 |
| 8.11 | Surry mean fire core damage frequency by fire area. | 8-8 |
| 8.12 | Peach Bottom mean fire core damage frequency by fire area. | 8-8 |
| 8.13 | Comparison of Surry internal core damage frequency with Reactor Safety Study. | 8-9 |
| 8.14 | Comparison of Peach Bottom internal core damage frequency with Reactor Safety Study. | 8-9 |
| 9.1 | Conditional probability of early containment failure for key plant damage states (PWRs). | 9-3 |
| 9.2 | Conditional probability of early containment failure for key plant damage states (BWRs). | 9-4 |
| 9.3 | Frequency of early containment failure or bypass (all plants). | 9-6 |
| 9.4 | Relative probability of containment failure modes (internal events). | 9-7 |
| 9.5 | Relative probability of containment failure modes (internal and external events, Surry and Peach Bottom). | 9-8 |
| 9.6 | Comparison of containment failure pressure with Reactor Safety Study (Surry). | 9-11 |
| 9.7 | Comparison of containment failure pressure with Reactor Safety Study (Peach Bottom). | 9-11 |
| 9.8 | Comparison of containment performance results with Reactor Safety Study (Surry and Peach Bottom). | 9-13 |
| 9.9 | Cumulative containment failure probability distribution for static pressurization (all plants). | 9-17 |
| 10.1 | Frequency of release for key radionuclide groups. | 10-2 |
| 10.2 | Comparison of source terms with Reactor Safety Study (Surry). | 10-5 |
| 10.3 | Comparison of source terms with Reactor Safety Study (Peach Bottom). | 10-7 |
| 12.1 | Comparison of early and latent cancer fatality risks at all plants (internal events). | 12-2 |
| 12.2 | Comparison of risk results at all plants with safety goals (internal events). | 12-3 |
| 12.3 | Comparison of early and latent cancer fatality risks at Surry and Peach Bottom (fire-initiated accidents). | 12-4 |
| 12.4 | Comparison of risk results at Surry and Peach Bottom with safety goals (fire-initiated accidents). | 12-5 |
| 12.5 | Frequency of one or more early fatalities at all plants. | 12-6 |
| 12.6 | Contributions of plant damage states to mean early and latent cancer fatality risks for Surry, Sequoyah, and Zion (internal events). | 12-8 |
| 12.7 | Contributions of plant damage states to mean early and latent cancer fatality risks for Peach Bottom and Grand Gulf (internal events). | 12-9 |
| 12.8 | Contributions of accident progression bins to mean early and latent cancer fatality risks for Surry, Sequoyah, and Zion (internal events). | 12-10 |
| 12.9 | Contributions of accident progression bins to mean early and latent cancer fatality risks for Peach Bottom and Grand Gulf (internal events). | 12-11 |
| 12.10 | Contributions of accident progression bins to mean early and latent cancer fatality risks for Surry and Peach Bottom (fire-initiated accidents). | 12-12 |

| | <i>Page</i> |
|--|-------------|
| 12.11 Effects of emergency response assumptions on early fatality risks at all plants (internal events). | 12-17 |
| 12.12 Effects of protective action assumptions on mean latent cancer fatality risks at all plants (internal events). | 12-18 |
| 13.1 Benefits of accident management strategies. | 13-5 |
| 13.2 Comparison of individual early and latent cancer fatality risks at all plants (internal initiators). | 13-8 |
| 13.3 Comparison of individual early and latent cancer fatality risks at Surry and Peach Bottom (fire initiators). | 13-9 |
| 13.4 Frequency of one or more early fatalities. | 13-10 |
| 13.5 Relative effectiveness of emergency response actions assuming early containment failure with high and low source terms. | 13-12 |
| 13.6 Relative effectiveness of emergency response actions assuming late containment failure with high and low source terms. | 13-13 |

TABLES

| | |
|--|-------|
| 2.1 Definition of some key NUREG-1150 risk analysis terms. | 2-3 |
| 2.2 Accident frequency analysis issues evaluated by expert panels. | 2-6 |
| 2.3 Accident progression and containment structural issues evaluated by expert panels. | 2-13 |
| 2.4 Source term issues evaluated by expert panel. | 2-16 |
| 3.1 Summary of design features: Surry Unit 1. | 3-2 |
| 3.2 Summary of core damage frequency results: Surry. | 3-4 |
| 4.1 Summary of design features: Peach Bottom Unit 2. | 4-2 |
| 4.2 Summary of core damage frequency results: Peach Bottom. | 4-4 |
| 5.1 Summary of design features: Sequoyah Unit 1. | 5-2 |
| 5.2 Summary of core damage frequency results: Sequoyah. | 5-4 |
| 6.1 Summary of design features: Grand Gulf Unit 1. | 6-2 |
| 6.2 Summary of core damage frequency results: Grand Gulf. | 6-5 |
| 7.1 Summary of design features: Zion Unit 1. | 7-2 |
| 7.2 Summary of core damage frequency results: Zion. | 7-4 |
| 11.1 Summaries of mean and median CCDFs of offsite consequences—fatalities. | 11-3 |
| 11.2 Summaries of mean and median CCDFs of offsite consequences—population exposures. | 11-4 |
| 11.3 Offsite protective measures assumptions. | 11-5 |
| 11.4 Exposure pathways relative contributions (percent) to meteorology-averaged conditional mean estimates of population dose for selected source term groups. | 11-7 |
| 11.5 Assumptions on alternative emergency response modes within 10-mile plume exposure pathway EPZ for sensitivity analysis. | 11-11 |
| 11.6 Sensitivity of mean CCDF of early fatalities to assumptions on offsite emergency response. | 11-12 |

| | <i>Page</i> |
|---|-------------|
| 11.7 Sensitivity of mean CCDFs of latent cancer fatalities and population exposures to the PAGs for living in contaminated areas—internal initiating events. | 11-14 |
| 13.1 Utility of NUREG-1150 PRA process to other plant studies. | 13-3 |

ACKNOWLEDGMENTS

This report is a summary of the risk analyses of five nuclear power plants performed under contract to NRC. It is the result of the tireless, creative, and professional efforts by a large number of people on the NRC staff and the staff of its contractors.

Overall management of the NUREG-1150 project was provided by:

Denwood Ross
Joseph Murphy
Mark Cunningham

NUREG-1150 Summary Report*

The principal authors of this summary report were:

| | |
|---|--------------------|
| Sarbes Acharya | James Glynn |
| Bharat Agrawal | James Johnson |
| Mark Cunningham | Pradyot Niyogi |
| Richard Denning (Battelle Memorial Institute— BMI) | Harold VanderMolen |

Other contributors were:

| | |
|---|---|
| Robert Bertucio (Energy Inc.—EI**) | Frederick Harper (SNL) |
| Roger Breeding (Sandia National Laboratories— SNL) | Alan Kolaczowski (SAIC) |
| Thomas Brown (SNL) | Mark Leonard (SAIC) |
| Allen Camp (SNL) | Chang Park (Brookhaven National Laboratory— BNL) |
| Wallis Cramond (SNL) | Arthur Payne (SNL) |
| Mary Drouin (Science Applications Incorporated—SAIC) | Trevor Pratt (BNL) |
| Elaine Gorham-Bergeron (SNL) | Martin Sattison (Idaho National Engineering Laboratory—INEL) |
| Julie Gregory (SNL) | Timothy Wheeler (SNL) |

NUREG-1150 Appendices*

This report has four appendices. The principal authors of Appendices A and B were:

| | |
|--------------------------------|------------------------------|
| Roger Breeding (SNL) | Elaine Gorham-Bergeron (SNL) |
| Mary Drouin (SAIC) | Martin Sattison (INEL) |
| David Ericson, Jr. (ERC, Inc.) | |

Other contributors included:

| | |
|----------------------|---|
| Michael Bohn (SNL) | Frederick Harper (SNL) |
| Gary Boyd (SAROS) | Jon Helton (Arizona State University—ASU) |
| Allen Camp (SNL) | John Lambright (SNL) |
| Wallis Cramond (SNL) | Timothy Wheeler (SNL) |

*The authors and contributors noted here were responsible for the development of the second draft of NUREG-1150. Those modifications needed to produce this final version (including the development of a fifth appendix) were made by Robert Bertucio (EI**), Allen Camp (SNL), Mark Cunningham (NRC), Richard Denning (BMI), Mary Drouin (SAIC), Frederick Harper (SNL), James Johnson (NRC), Joseph Murphy (NRC), John Lambright (SNL), Trevor Pratt (BNL), Christopher Ryder (NRC), and Martin Sattison (INEL). Final technical editing was performed by Louise Gallagher; final composition was performed by M Linda McKenzie and Ina H. Schwartz.

**Now with NUS Corporation.

The principal authors of Appendices C and D were:

Nilesh Chokshi (NRC)
Richard Denning (BMI)
Mark Leonard (SAIC)

Christopher Ryder (NRC)
Stephen Unwin (BMI)
John Wreathall (SAIC)

Other contributors to these appendices were:

Sarbes Acharya (NRC)
Christopher Amos (SAIC)
Roger Breeding (SNL)
Thomas Brown (SNL)
Allen Camp (SNL)
Wallis Cramond (SNL)
Mark Cunningham (NRC)
David Ericson, Jr. (ERC, Inc.)

Elaine Gorham-Bergeron (SNL)
Julie Gregory (SNL)
Frederick Harper (SNL)
Walter Murfin (Technadyne)
Joseph Murphy (NRC)
Pradyot Niyogi (NRC)
Arthur Payne (SNL)
Timothy Wheeler (SNL)

The detailed risk analyses underlying this report were performed under contract to NRC. The NRC staff project managers for these contracts were:

Bharat Agrawal
James Johnson
Pradyot Niyogi

David Pyatt*
Richard Robinson

Principal Contractor Reports

Within the contractor organizations, the staff involved in the risk analyses were:

Sandia National Laboratories

Principal Contributors:

Christopher Amos (SAIC)
Allan Benjamin
Robert Bertucio (EI)
Michael Bohn
Gary Boyd (SAROS)
Roger Breeding
Thomas Brown
Sharon Brown (EI)
Allen Camp
Wallis Cramond
Sharon Daniel
Mary Drouin (SAIC)
Elaine Gorham-Bergeron
Julie Gregory
Frederick Harper
Eric Haskin

Jon Helton (ASU)
Sarah Higgins
Ronald Iman
Jay Johnson (SAIC)
Hong-Nian Jow
Jeffrey Julius (EI)
Alan Kolaczowski (SAIC)
Jeffrey LaChance (SAIC)
John Lambright
Kevin Maloney
Walter Murfin (Technadyne)
Arthur Payne
Bonnie Shapiro (SAIC)
Ann Shiver
Lanny Smith
Jeremy Sprung
Teresa Sype
Timothy Wheeler

Other contributors were:

Ken Adams
Michael Allen
Kenneth Bergeron
Marshall Berman
Edward Boucheron
David Bradley
Rupert Byers

William Camp
Michael Carmel
David Chanin (Technadyne)
David Clauss
Dirk Dahlgren
Susan Dingman
Lisa Gallup (GRAM)

*Now with the U.S. Department of Energy.

Randall Gauntt
Michael Griesmeyer
Irving Hall
Phillip Hashimoto (EQE, Inc.)
Terry Heames (SAIC)
Jack Hickman
Steven Hora (U. of Hawaii)
Daniel Horschel
James Johnson (EQE)
Diane Jones (EI)
John Kelly
Stuart Lewis (SAROS)
David Kunsman
David McCloskey
Billy Marshall, Jr.
Joel Miller
David Moore (EI)
Kenneth Murata

Michael Mraz (EQE)
Nestor Ortiz
Martin Pilch
Dana Powers
Mark Quilici (EI)
Mayasandra Ravindra (EQE)
Judith Rollston (GRAM)
Martin Sherman
Michael Shortencarier
Douglas Stamps
William Tarbell
Wen Tong (EQE)
Walter Von Rieseemann
Jack Walker
Jay Weingardt (SAIC)
Ginger Wilkinson
David Williams

Brookhaven National Laboratory

Principal contributors:

Erik Cazzoli
Carrie Grimshaw
Min Lee*

Chang Park
Trevor Pratt
Arthur Tingle

Other contributors:

Robert Bari
Stephen Unwin**

Idaho National Engineering Laboratory

Principal contributors:

Martin Sattison

Kevin Hall

Other contributors:

Robert Bertucio (EI)
Peter Davis (PRD Consulting)

John Young (R. Lynette & Associates***)

Additional Technical Support

Additional technical support for the five risk analyses was obtained from other organizations and individuals. These included:

University of Southern California

Ralph Keeney
Detlof von Winterfeldt
Richard John
Ward Edwards

Los Alamos National Laboratory

Mary Meyer
Jane Booker

Battelle Memorial Institute

Richard Denning

*Now with National Tsing Hwa University, Taiwan.

**Now with Battelle Memorial Institute.

***Now with SAIC.

Lee Ann Curtis
Peter Cybulskis
Hans Jordan
Rita Freeman-Kelly

Vladimir Kogan
Philip Shumacher
Stephen Unwin
Roger Wooton

Quality Assurance Teams

Quality assurance and control teams were formed to review the risk analyses. Members of these teams were:

Accident Frequency Analysis

Gary Boyd (SAROS)
David Kunsman (SNL)
Garreth Parry (NUS)

Arthur Payne (SNL)
John Wreathall (SAIC)

Risk Analysis

Kenneth Bergeron (SNL)
Gary Boyd (SAROS)
David Bradley (SNL)
Richard Denning (BMI)
Susan Dingman (SNL)

John Kelly (SNL)
David Kunsman (SNL)
Stuart Lewis (SAROS)
David Pyatt (NRC)
John Zehner (BNL)

Expert Panels

Panels of experts were used to develop probability distributions for a number of key parameters in the risk analyses. Members of the expert panels were:

Accident Frequency Issues

Barbara Bell (BMI)
Dennis Bley (Pickard, Lowe and Garrick,
Inc.—PLG)
Gary Boyd (SAROS)
Robert Budnitz (Future Resource Associates,
Inc.)
Larry Bustard (SNL)

Karl Fleming (PLG)
Michael Hitchler (Westinghouse)
Jerry Jackson (NRC)
Joseph Murphy (NRC)
Garreth Parry (NUS)
David Rhodes (Atomic Energy of Canada
Limited)

In-Vessel Accident Phenomenological Issues

Peter Bieniarz (Risk Management Associates—
RMA)
William Camp (SNL)
Vernon Denny (SAIC)
Richard Hobbins (INEL)
Steven Hodge (Oak Ridge National Laboratory—
ORNL)

Robert Lutz (Westinghouse)
Michael Podowski (Rensselaer Polytechnic
Institute)
Garry Thomas (Electric Power Research
Institute—EPRI)
Robert Wright (NRC)

Containment Loading Issues

Louis Baker (Argonne National Laboratory)
Kenneth Bergeron (SNL)
Theodore Ginsburg (BNL)
James Metcalf (Stone and Webster Engineering
Corp.—S&W)

Martin Plys (Fauske and Associates, Inc.—FAI)
Martin Sherman (SNL)
Patricia Worthington (NRC)
Alfred Torri (PLG)

Molten Core Containment Issues

David Bradley (SNL)

Michael Corradini (University of Wisconsin)

George Greene (BNL)
Michael Hazzan (S&W)

Mujid Kazimi (Massachusetts Institute of
Technology)
Raj Sehgal (EPRI)

Containment Structural Response Issues

David Clauss (SNL)
Charles Miller (CCNY)
Kam Mokhtarian (Chicago Bridge and Iron,
Inc.)
Joseph Rashid (ANATECH)
Subir Sen (Bechtel Power Corp.)

Richard Tolen (United Engineers and
Construction)
Walter Von Rieseemann (SNL)
Adolph Walser (Sargent and Lundy Engineers)
J. Randall Weatherby (SNL)
Donald Wesley (IMPELL)

Source Term Issues

Peter Bieniarz (RMA)
Andrzej Drozd (S&W)
James Gieseke (BMI)
Robert Henry (FAI)
Thomas Kress (ORNL)

Y.H. (Ben) Liu (University of Minnesota)
Dana Powers (SNL)
Richard Vogel (EPRI)
David Williams (SNL)

Other Support

The publication of this report could not have been achieved without substantial help from other NRC staff members. These included: Leslie Lancaster and Richard Robinson (technical review); Louise Gallagher (editorial review); Veronica Blackstock, Annette Spain, Jean Shipley, Mahmooda Bano, Debra Veltri, Wanda Haag (word processing support); and Joanne Johansen, M Linda McKenzie, Bonnie Epps, Jane Corley, Marianne Bender, and Jeanette Kiminas from Electronic Composition Services, Office of Administration (final report composition).

PART I

Introduction

Summary of Methods

1. INTRODUCTION

1.1 Background

In 1975, the U.S. Nuclear Regulatory Commission (NRC) completed the first study of the probabilities and consequences of severe reactor accidents in commercial nuclear power plants—the Reactor Safety Study (RSS) (Ref. 1.1). This work for the first time used the techniques of probabilistic risk analysis (PRA) for the study of core meltdown accidents in two commercial nuclear power plants. The RSS indicated that the probabilities of such accidents were higher than previously believed but that the offsite consequences were significantly lower. The product of probability and consequence—a measure of the risk of severe accidents—was estimated to be quite low relative to other man-made and naturally occurring risks.

Following the completion of these first PRAs, the NRC initiated research programs to improve the staff's ability to assess the risks of severe accidents in light-water reactors. Development began on advanced methods for assessing the frequencies of accidents. Improved means for the collection and use of plant operational data were put into place, and advanced methods for assessing the impacts of human errors and other common-cause failures were developed. In addition, research was begun on key severe accident physical processes identified in the RSS, such as the interactions of molten core material with concrete.

In parallel, the NRC staff began to gradually introduce the use of PRA in its regulatory process. The importance to public risk of a spectrum of generic safety issues facing the staff was investigated and a list of higher priority issues developed (Ref. 1.2). Risk studies of other plant designs were begun (Ref. 1.3). However, such uses of PRA by the staff were significantly tempered by the peer review of the RSS, commonly known as the Lewis Committee report (Ref. 1.4), and the subsequent Commission policy guidance to the staff (Ref. 1.5).

The 1979 accident at Three Mile Island substantially changed the character of NRC's analysis of severe accidents and its use of PRA. Based on the comments and recommendations of both major investigations of this accident (the Kemeny and Rogovin studies (Refs. 1.6 and 1.7)), a substantial research program on severe accident phenomenology was planned and initiated (Refs. 1.8 and 1.9). This program included experimental and analytical studies of accident physical processes.

Computer models were developed to simulate these processes. The Kemeny and Rogovin investigations also recommended that PRA be used more by the staff to complement its traditional, nonprobabilistic methods of analyzing nuclear plant safety. In addition, the Rogovin investigation recommended that NRC policy on severe accidents be reconsidered in two respects: the need to specifically consider more severe accidents (e.g., those involving multiple system failures) in the licensing process, and the need for probabilistic safety goals to help define the level of plant safety that was "safe enough."

By the mid-1980's, the technology for analyzing the physical processes of severe accidents had evolved to the point that a new computational model of severe accident physical processes had been developed—the Source Term Code Package—and subjected to peer review (Ref. 1.10). General procedures for performing PRAs were developed (Ref. 1.11), and a summary of PRA perspectives available at that time was published (Ref. 1.12). The Commission had developed and approved policy guidance on how severe accident risks were to be assessed by NRC (Ref. 1.13), as well as safety goals against which these risks could be measured (Ref. 1.14) and methods by which potential safety improvements could be evaluated (Ref. 1.15).

In 1988, the staff requested information on the assessment of severe accident vulnerabilities by each licensed nuclear power plant (Ref. 1.16). This "individual plant examination" could be done either with PRA or other approved means. (In response, virtually all licensees indicated that they intended to perform PRAs in their assessments.) The staff also developed its plans for integrating the reviews of these examinations with other severe accident-related activities by the staff and for coming to closure on severe accident issues on the set of operating nuclear power plants (Ref. 1.17).

One principal supporting element to the staff's severe accident closure process is the reassessment of the risks of such accidents, using the technology developed through the 1980's. This reassessment updates the first staff PRA—the Reactor Safety Study—and provides a "snapshot" (in time) of estimated plant risks in 1988 for five commercial nuclear power plants of different design. For this reassessment, the plants have been studied by teams of PRA specialists under contract to NRC (Refs. 1.18 through 1.31). This report,

1. Introduction

NUREG-1150, summarizes the results of these studies and provides perspectives on how the results may be used by the NRC staff in carrying out its safety and regulatory responsibilities.

NUREG-1150 was first issued in draft form in February 1987 for public comment. In response, 55 sets of comments were received, totaling approximately 800 pages. In addition, comments were received from three organized peer review committees, two sponsored by NRC (Refs. 1.32 and 1.33) and one by the American Nuclear Society (Ref. 1.34). Appendix D provides a summary of the principal comments (and their authors) on this first draft of NUREG-1150 and the staff's responses. A second draft version of NUREG-1150 was issued in June 1989, taking into account the comments received and reflecting improvements in methods identified in the course of performing the draft risk analyses, in the design and operation of the studied plants, and in the information base of severe accident phenomenology.

Because of the significant criticisms of the first draft of NUREG-1150, and the substantial changes made in response, the second version of the report was issued as a draft for peer review. A review committee was established under the provisions of the Federal Advisory Committee Act (Ref. 1.35). This committee reviewed the report for approximately 1 year and published its results in August 1990 (Ref. 1.36). In parallel, the American Nuclear Society-sponsored review of the report continued; its results were published in June 1990 (Ref. 1.37). Also, the NRC's Advisory Committee on Reactor Safeguards (ACRS) reviewed the analyses and provided comments (Ref. 1.38). Four sets of public comments were also received. While all committees suggested that some changes be made to the report, the comments received were, in general, positive, with all review committees recommending that the report be published in final form as soon as possible and without extensive reanalysis or changes.

This is the final version of NUREG-1150. In keeping with the review committees' recommendations, the staff has made relatively modest changes to the second draft of the report, with essentially no additional technical analysis. (Appendix E provides a summary of the comments and recommendations made by the review committees and the staff's responses. It also includes the ACRS comments in toto.)

Two other recommendations of the review committees should also be noted here. First, the ANS

committee indicated that the changes made between the first and second drafts of NUREG-1150 were so substantial that the former should be considered, in effect, obsolete. The staff agrees with this comment and recommends that the analyses and results contained in the first draft no longer be used. Second, the ACRS cautioned that the results should be used only by those who have a thorough understanding of their limitations. The staff agrees with this comment as well.

1.2 Objectives

The objectives of this report are:

- To provide a current assessment of the severe accident risks of five nuclear power plants of different design, which:
 - Provides a snapshot of risks reflecting plant design and operational characteristics, related failure data, and severe accident phenomenological information available as of March 1988;
 - Updates the estimates of NRC's 1975 risk assessment, the Reactor Safety Study;
 - Includes quantitative estimates of risk uncertainty in response to a principal criticism of the Reactor Safety Study; and
 - Identifies plant-specific risk vulnerabilities for the five studied plants, supporting the development of the NRC's individual plant examination (IPE) process;
- To summarize the perspectives gained in performing these risk analyses, with respect to:
 - Issues significant to severe accident frequencies, containment performance, and risks;
 - Risk-significant uncertainties that may merit further research;
 - Comparisons with NRC's safety goals; and
 - The potential benefits of a severe accident management program in reducing accident frequencies; and
- To provide a set of PRA models and results that can support the ongoing prioritization of potential safety issues and related research.

In considering these objectives and the risk analyses in this and supporting contractor reports, it is important to consider both what NUREG-1150 is and what it is not:

- NUREG-1150 is a snapshot in time of severe accident risks in five specific commercial nuclear power plants. This snapshot is obtained using, in general, PRA techniques and severe accident phenomenological information of the mid-1980's, but with significant advances in certain areas. The plant analyses reflect design and operational information as of roughly March 1988.
- NUREG-1150 is an important resource document for the NRC staff, providing quantitative and qualitative PRA information on a set of five commercial nuclear power plants of different design with respect to important severe accident sequences, and a means for investigating where safety improvements might best be pursued, the cost-effectiveness of possible plant modifications, the importance of generic safety issues, and the sensitivity of risks to issues as they arise.
- NUREG-1150 is an estimate of the actual risks of the five studied plants. It is a set of modern PRAs, having the limitations of all such studies. These limitations relate to the quantitative measurement of certain types of human actions (errors of commission, heroic recovery actions); variations in the licensee's organizational/management safety commitments; failure rates of equipment, especially to common-cause effects such as maintenance, environment, design and construction errors, and aging; sabotage risks; and an incomplete understanding of the physical progression and consequences of core damage accidents.
- NUREG-1150 is not the sole basis for making plant-specific or generic regulatory decisions. Such decisions must be more broadly based on information on the extant set of regulatory requirements, reflecting the present level of required safety, cost-benefit studies (in some circumstances), risk analysis results (from this and other relevant PRAs), and other technical and legal considerations.
- NUREG-1150 is not an estimate of the risks of all commercial nuclear power plants in the United States or abroad. One of the clear perspectives from this study of severe accident risks and other such studies is that char-

acteristics of design and operation specific to individual plants can have a substantial impact on the estimated risks.

1.3 Scope of Risk Analyses

The five risk analyses discussed in this report include the analysis of the frequency of severe accidents, the performance of containment and other mitigative systems and structures in such accidents, and the offsite consequences (health effects, property damage, etc.) of these accidents. In assessing accident frequencies, the five risk analyses consider events initiated while the reactor is at full-power operation.* For two plants, both "internal" events (e.g., random failures of plant equipment, operator errors) and "external" events (e.g., earthquakes, fires) have been considered as initiating events. For the remaining three plants, only internal events have been studied.

The five commercial nuclear power plants studied in this report are:

- Unit 1 of the Surry Power Station, a Westinghouse-designed three-loop reactor in a subatmospheric containment building, located near Williamsburg, Virginia (including the analysis of both internal and external events);**
- Unit 1 of the Zion Nuclear Plant, a Westinghouse-designed four-loop reactor in a large, dry containment building, located near Chicago, Illinois;
- Unit 1 of the Sequoyah Nuclear Power Plant, a Westinghouse-designed four-loop reactor in an ice condenser containment building, located near Chattanooga, Tennessee;
- Unit 2 of the Peach Bottom Atomic Power Station, a General Electric-designed BWR-4 reactor in a Mark I containment building, located near Lancaster, Pennsylvania (including the analysis of both internal and external events);** and
- Unit 1 of the Grand Gulf Nuclear Station, a General Electric-designed BWR-6 reactor in a Mark III containment building, located near Vicksburg, Mississippi.

*Analysis of shutdown and low-power accident risks for the Surry and Grand Gulf plants was initiated in FY 1989.

**These plants were used as models in the Reactor Safety Study.

1. Introduction

The external-event analysis summarized in this report includes discussion of the core damage frequency and containment performance from seismically initiated accidents. The offsite consequences and risks are not provided. The reason for this limitation is related to the offsite effects of a large earthquake.

Two sets of hazard curves are used (and reported separately) in the seismic analysis. One set was prepared by Lawrence Livermore National Laboratory (Ref. 1.39) under contract to NRC. Analysis performed using these hazard curves (which have been prepared for the Surry and Peach Bottom sites and other reactor sites east of the Rocky Mountains) suggest that relatively rare but large earthquakes contribute significantly to the risk from seismic events. A second set of hazard curves was also prepared for sites east of the Rocky Mountains for the Electric Power Research Institute (Ref. 1.40). Although both projects made extensive use of expert judgment and formal methods for obtaining these judgments (as did many parts of this project, as discussed in Chapter 2), there were some important differences in methods. Nonetheless, the NRC believes that at present both methods are fundamentally sound.

A significant portion of the estimated seismic-induced core damage frequency for the Surry and Peach Bottom plants arises from large earthquakes. Should such a large earthquake occur in the Eastern United States (e.g., at the Surry or Peach Bottom site), there would likely be substantial damage to some older residential structures, commercial structures, and high hazard facilities such as dams. This could have a major societal impact over a large region, including property damage, injuries, and fatalities. The technology for assessing losses from such earthquakes is a developing one. There are several studies of this technology at this time, including work at the United States Geological Survey. There is no agreed-upon method for this purpose, although a recent report of the National Academy of Sciences (Ref. 1.41) suggests some broad guidelines. The NRC, in its promulgation of safety goals, indicated a preference for quantitative goals in the form of a ratio or percentage of nuclear risks relative to non-nuclear risks. For example, the probability of an early fatality from a nuclear power plant accident should not exceed 1/1000 of the "background" accidental death rate. The NRC intends to further investigate the methods for assessing losses from earthquakes in the vicinity of the

Surry and Peach Bottom sites with a view of comparing the ratio of seismically induced reactor accident losses with the overall losses. There has been at least one study (Ref. 1.42) that suggests that the reactor accident contribution to seismic losses is very small relative to the non-nuclear losses. However, this study did not explicitly consider the two sites of interest in this report.

In contrast, because they are aimed at experts in the field of risk analysis, the contractor reports underlying this report (Refs. 1.20, 1.21, 1.27, and 1.28) present the seismic risk results in the form of a set of sensitivity analyses. These analyses consider the effects of the alternative sets of earthquake frequencies and severities noted above, as well as alternative assumptions on the performance of containment structures in large earthquakes, and the possible regional effects of earthquakes (lack of shelter, difficulty in evacuation and relocation, nonradiologically induced injuries and fatalities, etc.) on estimates of plant risk. The reader is cautioned that the results presented in the contractor reports should be used only in the broader context of the overall societal response.

1.4 Structure of NUREG-1150 and Supporting Documents

This report has three parts:

- Part I discusses the background, objectives, and methods used in this assessment of severe accident risks;
- Part II provides summary results and discussion of the individual risk studies of the five examined plants; and
- Part III provides:
 - Perspectives on the collective results of these five PRAs, organized by the principal subject areas of risk analysis: accident frequencies; accident progression, containment loadings, and structural response; transport of radioactive material; offsite consequences; and integrated risk (the product of frequencies and consequences);
 - Discussion of how the risk estimates have changed (and reasons why) for the two plants studied in both the Reactor Safety Study and this report (Surry and Peach Bottom); and

- Discussion of the role of NUREG-1150 as a resource document in the staff's assessment of severe accidents.

Three appendices are contained in Volume 2 of this report. Appendix A discusses in greater detail the methods used to perform the five risk analyses.* In Appendix B, an example calculation is provided to describe the flow of data through the individual elements of the NUREG-1150 risk analysis process. Appendix C provides supplemental information on key technical issues in the risk analyses. Volume 3 contains two additional appendices. As indicated previously, Appendices D and E provide summaries of comments received on the first and second versions of draft NUREG-1150, respectively, and the associated responses.

As noted above, this report provides a summary of five PRAs performed under contract to NRC. Volume 1 is written for an intended audience of people with a general familiarity with nuclear reac-

tor safety and probabilistic risk analysis. Appendices A, B, and C are written for an intended audience of specialists in reactor safety and risk analysis.

As shown in Figure 1.1, supporting this report are a series of contractor reports providing the detailed substance of the five risk studies. These reports are written for specialists in reactor safety and PRA. The staff's principal contractors for this work have been:

- Sandia National Laboratories, Albuquerque, New Mexico;
- Brookhaven National Laboratory, Upton, New York;
- Idaho National Engineering Laboratory, Idaho Falls, Idaho;
- Battelle Memorial Institute, Columbus, Ohio; and
- Los Alamos Scientific Laboratory, Los Alamos, New Mexico.

*The sections of Appendix A are adapted, with editorial modification, from References 1.18 and 1.25.

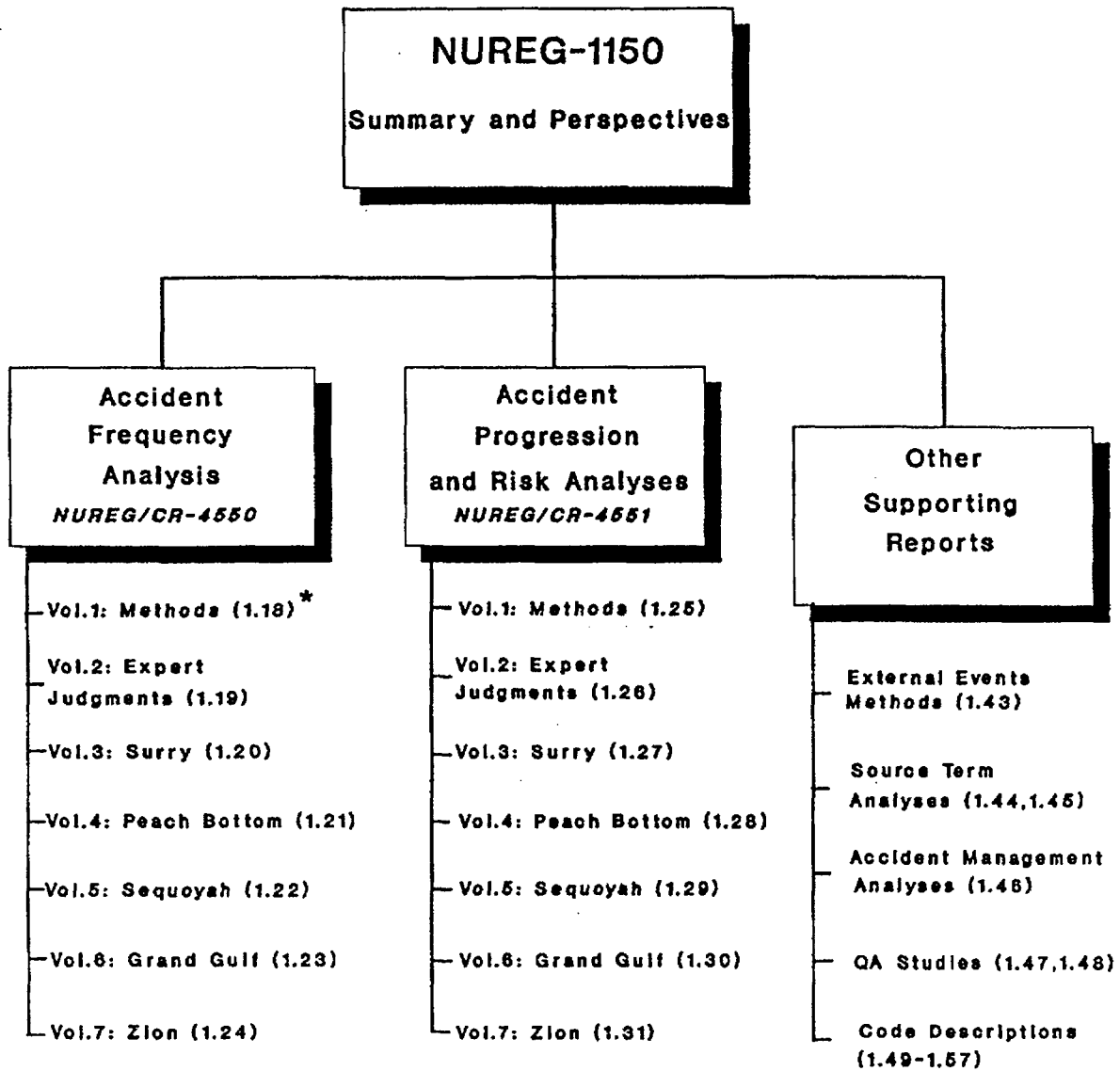

*See reference list at end of Chapter 1.

Figure 1.1 Reports supporting NUREG-1150.

REFERENCES FOR CHAPTER 1

- 1.1 U.S. Nuclear Regulatory Commission (USNRC), "Reactor Safety Study—An Assessment of Accident Risks in U.S. Commercial Nuclear Power Plants," WASH-1400 (NUREG-75/014), October 1975.
- 1.2 USNRC, "Reporting the Progress of Resolution of Unresolved Safety Issues in the NRC Annual Report," SECY-78-616, November 27, 1978.
- 1.3 D. D. Carlson et al., "Reactor Safety Study Methodology Applications Program," Sandia National Laboratories, NUREG/CR-1659, Vol. 1, SAND80-1897, April 1981.
- 1.4 H. W. Lewis et al., "Risk Assessment Review Group Report to the U.S. Nuclear Regulatory Commission," NUREG/CR-0400, September 1978.
- 1.5 USNRC, "NRC Statement on Risk Assessment and the Reactor Safety Study Report (WASH-1400) in Light of the Risk Assessment Review Group Report," January 18, 1979.
- 1.6 J. G. Kemeny et al., "Report of the President's Commission on the Accident at Three Mile Island," October 1979.
- 1.7 M. Rogovin et al., "Three Mile Island—A Report to the Commissioners and to the Public," NUREG/CR-1250, Vol. 1, January 1980.
- 1.8 J. T. Larkins and M. A. Cunningham, "Nuclear Power Plant Severe Accident Research Plan," USNRC Report NUREG-0900, January 1983.
- 1.9 G. P. Marino (Ed.), "Nuclear Power Plant Severe Accident Research Plan," USNRC Report NUREG-0900, Revision 1, April 1986.
- 1.10 M. Silberberg et al., "Reassessment of the Technical Bases for Estimating Source Terms," USNRC Report NUREG-0956, July 1986.
- 1.11 J. W. Hickman et al., "PRA Procedures Guide. A Guide to the Performance of Probabilistic Risk Assessments for Nuclear Power Plants," American Nuclear Society, NUREG/CR-2300, Vols. 1 and 2, January 1983.
- 1.12 USNRC, "Probabilistic Risk Assessment Reference Document," NUREG-1050, September 1984.
- 1.13 USNRC, "Policy Statement on Severe Reactor Accidents Regarding Future Design and Existing Plants," *Federal Register*, Vol. 50, p. 32138, August 8, 1985.
- 1.14 USNRC, "Safety Goals for the Operation of Nuclear Power Plants; Policy Statement," *Federal Register*, Vol. 51, p. 30028, August 21, 1986.
- 1.15 USNRC, "Revision of Backfitting Process for Power Reactors," *Federal Register*, Vol. 53, p. 20603, June 6, 1988.
- 1.16 USNRC, "Individual Plant Examinations for Severe Accident Vulnerabilities—10 CFR 50.54(f)," Generic Letter 88-20, November 23, 1988.
- 1.17 USNRC, "Integration Plan for Closure of Severe Accident Issues," SECY-88-147, May 25, 1988.
- 1.18 D. M. Ericson, Jr., (Ed.) et al., "Analysis of Core Damage Frequency: Internal Events Methodology," Sandia National Laboratories, NUREG/CR-4550, Vol. 1, Revision 1, SAND86-2084, January 1990.
- 1.19 T. A. Wheeler et al., "Analysis of Core Damage Frequency from Internal Events: Expert Judgment Elicitation," Sandia National Laboratories, NUREG/CR-4550, Vol. 2, SAND86-2084, April 1989.
- 1.20 R. C. Bertucio and J. A. Julius, "Analysis of Core Damage Frequency: Surry Unit 1," Sandia National Laboratories, NUREG/CR-4550, Vol. 3, Revision 1, SAND86-2084, April 1990.
- 1.21 A. M. Kolaczowski et al., "Analysis of Core Damage Frequency: Peach Bottom Unit 2," Sandia National Laboratories, NUREG/CR-4550, Vol. 4, Revision 1, SAND86-2084, August 1989.

1. Introduction

- 1.22 R. C. Bertucio and S. R. Brown, "Analysis of Core Damage Frequency: Sequoyah Unit 1," Sandia National Laboratories, NUREG/CR-4550, Vol. 5, Revision 1, SAND86-2084, April 1990.
- 1.23 M. T. Drouin et al., "Analysis of Core Damage Frequency: Grand Gulf Unit 1," Sandia National Laboratories, NUREG/CR-4550, Vol. 6, Revision 1, SAND86-2084, September 1989.
- 1.24 M. B. Sattison and K. W. Hall, "Analysis of Core Damage Frequency: Zion Unit 1," Idaho National Engineering Laboratory, NUREG/CR-4550, Vol. 7, Revision 1, EGG-2554, May 1990.
- 1.25 E. D. Gorham-Bergeron et al., "Evaluation of Severe Accident Risks: Methodology for the Accident Progression, Source Term, Consequence, Risk Integration, and Uncertainty Analyses," Sandia National Laboratories, NUREG/CR-4551, Vol. 1, Draft Revision 1, SAND86-1309, to be published.*
- 1.26 F. T. Harper et al., "Evaluation of Severe Accident Risks: Quantification of Major Input Parameters," Sandia National Laboratories, NUREG/CR-4551, Vol. 2, Revision 1, SAND86-1309, December 1990.
- 1.27 R. J. Breeding et al., "Evaluation of Severe Accident Risks: Surry Unit 1," Sandia National Laboratories, NUREG/CR-4551, Vol. 3, Revision 1, SAND86-1309, October 1990.
- 1.28 A. C. Payne, Jr., et al., "Evaluation of Severe Accident Risks: Peach Bottom Unit 2," Sandia National Laboratories, NUREG/CR-4551, Vol. 4, Draft Revision 1, SAND86-1309, to be published.*
- 1.29 J. J. Gregory et al., "Evaluation of Severe Accident Risks: Sequoyah Unit 1," Sandia National Laboratories, NUREG/CR-4551, Vol. 5, Revision 1, SAND86-1309, December 1990.
- 1.30 T. D. Brown et al., "Evaluation of Severe Accident Risks: Grand Gulf Unit 1," Sandia National Laboratories, NUREG/CR-4551, Vol. 6, Draft Revision 1, SAND86-1309, to be published.*
- 1.31 C. K. Park et al., "Evaluation of Severe Accident Risks: Zion Unit 1," Brookhaven National Laboratory, NUREG/CR-4551, Vol. 7, Draft Revision 1, BNL-NUREG-52029, to be published.*
- 1.32 H. J. C. Kouts et al., "Methodology for Uncertainty Estimation in NUREG-1150 (Draft): Conclusions of a Review Panel," Brookhaven National Laboratory, NUREG/CR-5000, BNL-NUREG-52119, December 1987.
- 1.33 W. E. Kastenbergh et al., "Findings of the Peer Review Panel on the Draft Reactor Risk Reference Document, NUREG-1150," Lawrence Livermore National Laboratory, NUREG/CR-5113, UCID-21346, May 1988.
- 1.34 L. LeSage et al., "Initial Report of the Special Committee on Reactor Risk Reference Document (NUREG-1150)," American Nuclear Society, April 1988.
- 1.35 USNRC, "Special Committee To Review the Severe Accident Risks Report," *Federal Register*, Vol. 54, p. 26124, June 21, 1989.
- 1.36 H. J. C. Kouts et al., "Special Committee Review of the Nuclear Regulatory Commission's Severe Accident Risks Report (NUREG-1150)," NUREG-1420, August 1990.
- 1.37 L. LeSage et al., "Report of the Special Committee on NUREG-1150, The NRC's Study of Severe Accident Risks," American Nuclear Society, June 1990.
- 1.38 Letter from Carlyle Michelson, Chairman, ACRS, to Kenneth M. Carr, Chairman, NRC, "Review of NUREG-1150, 'Severe Accident Risks: An Assessment of Five U.S. Nuclear Power Plants,'" November 15, 1990.
- 1.39 D. L. Bernreuter et al., "Seismic Hazard Characterization of 69 Nuclear Power Sites East of the Rocky Mountains," Lawrence Livermore National Laboratory, NUREG/CR-5250, Vols. 1-8, UCID-21517, January 1989.
- 1.40 Seismicity Owners Group and Electric Power Research Institute, "Seismic Hazard Methodology for the Central and Eastern United States," Electric Power Research Institute, EPRI NP-4726, July 1986.

*Available in the NRC Public Document Room, 2120 L Street NW., Washington, DC.

- 1.41 National Academy of Sciences, "Estimating Losses from Future Earthquakes—Panel Report," Panel on Earthquake Loss Estimation Methodology, National Academy Press, 1989.
- 1.42 Y. T. Lee et al., "A Comparison of Background Seismic Risks and the Incremental Seismic Risk Due to Nuclear Power Plants," *Nuclear Engineering and Design*, 53(1979), pp. 141-154.
- 1.43 M. P. Bohn and J. A. Lambright, "Procedures for the External Event Core Damage Frequency Analyses for NUREG-1150," Sandia National Laboratories, NUREG/CR-4840, SAND88-3102, November 1990.
- 1.44 R. S. Denning et al., "Report on Radio-nuclide Release Calculations for Selected Severe Accident Scenarios," Battelle Columbus Division, NUREG/CR-4624, Vols. 1-5, BMI-2139, July 1986.
- 1.45 R. S. Denning et al., "Report on Radio-nuclide Release Calculations for Selected Severe Accident Scenarios: Supplemental Calculations," Battelle Columbus Division, NUREG/CR-4624, Vol. 6, BMI-2139, August 1990.
- 1.46 A. L. Camp et al., "The Risk Management Implications of NUREG-1150 Methods and Results," Sandia National Laboratories, NUREG/CR-5263, SAND88-3100, September 1989.
- 1.47 P. Cybulskis, "Assessment of the XSOR Codes," Battelle Columbus Division, NUREG/CR-5346, BMI-2171, November 1989.
- 1.48 C. A. Dobbe et al., "Quality Assurance and Verification of the MACCS Code Version 1.5," Idaho National Engineering Laboratory, NUREG/CR-5376, EGG-2566, February 1990.
- 1.49 R. L. Iman and M. J. Shortencarier, "A User's Guide for the Top Event Matrix Analysis Code (TEMAC)," Sandia National Laboratories, NUREG/CR-4598, SAND86-0960, August 1986.
- 1.50 R. L. Iman and M. J. Shortencarier, "A Fortran 77 Program and User's Guide for the Generation of Latin Hypercube and Random Samples for Use with Computer Models," Sandia National Laboratories, NUREG/CR-3624, SAND83-2365, June 1984.
- 1.51 D. W. Stack, "A SETS User's Manual for Accident Sequence Analysis," Sandia National Laboratories, NUREG/CR-3547, SAND83-2238, January 1984.
- 1.52 K. D. Russell et al., "Integrated Reliability and Risk Analysis System (IRRAS) Version 2.0 User's Guide," Idaho National Engineering Laboratory, NUREG/CR-5111, EGG-2535, June 1990.
- 1.53 J. M. Griesmeyer and L. N. Smith, "A Reference Manual for the Event Progression Analysis Code (EVNTRE)," Sandia National Laboratories, NUREG/CR-5174, SAND88-1607, September 1989.
- 1.54 H. N. Jow et al., "XSOR Codes User's Manual," Sandia National Laboratories, NUREG/CR-5360, SAND89-0943, to be published.*
- 1.55 R. L. Iman et al., "PARTITION: A Program for Defining the Source Term/Consequence Analysis Interface in the NUREG-1150 Probabilistic Risk Assessments," Sandia National Laboratories, NUREG/CR-5253, SAND88-2940, May 1990.
- 1.56 D. I. Chanin, H. N. Jow, J. A. Rollstin et al., "MELCOR Accident Consequence Code System (MACCS)," Sandia National Laboratories, NUREG/CR-4691, Vols. 1-3, SAND86-1562, February 1990.
- 1.57 S. J. Higgins, "A User's Manual for the Postprocessing Program PSTEVNT," Sandia National Laboratories, NUREG/CR-5380, SAND88-2988, November 1989.

*Available in the NRC Public Document Room, 2120 L Street NW., Washington, DC.

2. SUMMARY OF METHODS

2.1 Introduction

In many respects, the five probabilistic risk analyses (PRAs) performed in support of this report (Refs. 2.1 through 2.14) have been performed using PRA methods typical of the mid-1980's (Refs. 2.15 and 2.16). However, in certain areas, more advanced techniques have been applied. In particular, advancements have occurred in the following areas:

- The estimation of the size of the uncertainties in core damage frequency* and risk due to incomplete understanding of the systems responses, severe accident progression, containment building structural response, and in-plant radioactive material transport;
- The formal elicitation and documentation of expert judgments;**
- The more detailed definition of plant damage states, improving the efficiency of the interface between the accident frequency and accident progression analyses;
- The types of events and outcomes explicitly considered in the accident progression and containment loading analyses;
- The analysis of radioactive material releases and the integration of experimental and calculational results into this analysis;
- The use of more efficient methods for estimating the frequency of core damage accidents resulting from external events (e.g., earthquakes); and
- The application of new computer models in the analysis and integration of risk information.

The assessment of severe accident risks performed for this report can be divided into five general parts (shown in Fig. 2.1): accident frequency; accident progression, containment loading, and structural response; transport of radioactive material; offsite consequences; and integrated risk analyses. This last part combines

the information from the first four parts into estimates of risk. These parts are described in Sections 2.2, 2.3, 2.4, 2.5, and 2.8, respectively. Additional discussion of each of these parts is provided in Appendix A and in substantial detail in References 2.1 and 2.8.

Because the estimation of uncertainties in core damage frequency and risk due to uncertainties in the constituent analyses is important to the overall objectives of this study, the descriptions of the constituent analyses will include discussions of uncertainties. The parts of the accident frequency analyses, the accident progression analyses, the containment building structural response analyses, and the radioactive transport analyses that are highly uncertain have been identified. In place of single "best estimates" for parameters representing these uncertain parts of the analyses, probability distributions have been developed. The methods for obtaining probability distributions for uncertain parameters (through, for the most part, the use of expert judgment) and the methods by which the probability distributions in the constituent analyses are propagated through the analyses to yield estimates of the uncertainties in core damage frequency and risk are described in Sections 2.7 and 2.6, respectively. Additional discussion of these two subjects is provided in Sections 6 and 7 of Appendix A and in detail in References 2.1 and 2.8.

The principal results obtained from the five PRAs that form the basis of this report are probability distributions. For simplicity, these distributions may be described by a number of statistical characteristics. The characteristics generally used in this report are the mean, the median, and 5th percentile and 95th percentile of the distributions. No one characteristic conveys all the information necessary to describe the distribution, and any one can be misleading. In particular, for very broad distributions (spanning several orders of magnitude), the mean can be dominated by the high value part of the distribution. If this is also a low probability part of the distribution, the estimate of the mean can exhibit a high degree of statistical variability. Conclusions based on mean values of such distributions must be carefully examined to ensure that dependencies and trends seen in the mean values apply to entire distributions. Conclusions stated in this report have not been based entirely on characteristics of mean values. In some circumstances, median values or entire distributions are used. In particular, the

*Table 2.1 provides definitions of key terms used in this report.

**Risk analyses and other technical studies routinely make use of expert judgment. It is the use of formal procedures to obtain and document these judgments that is noteworthy here.

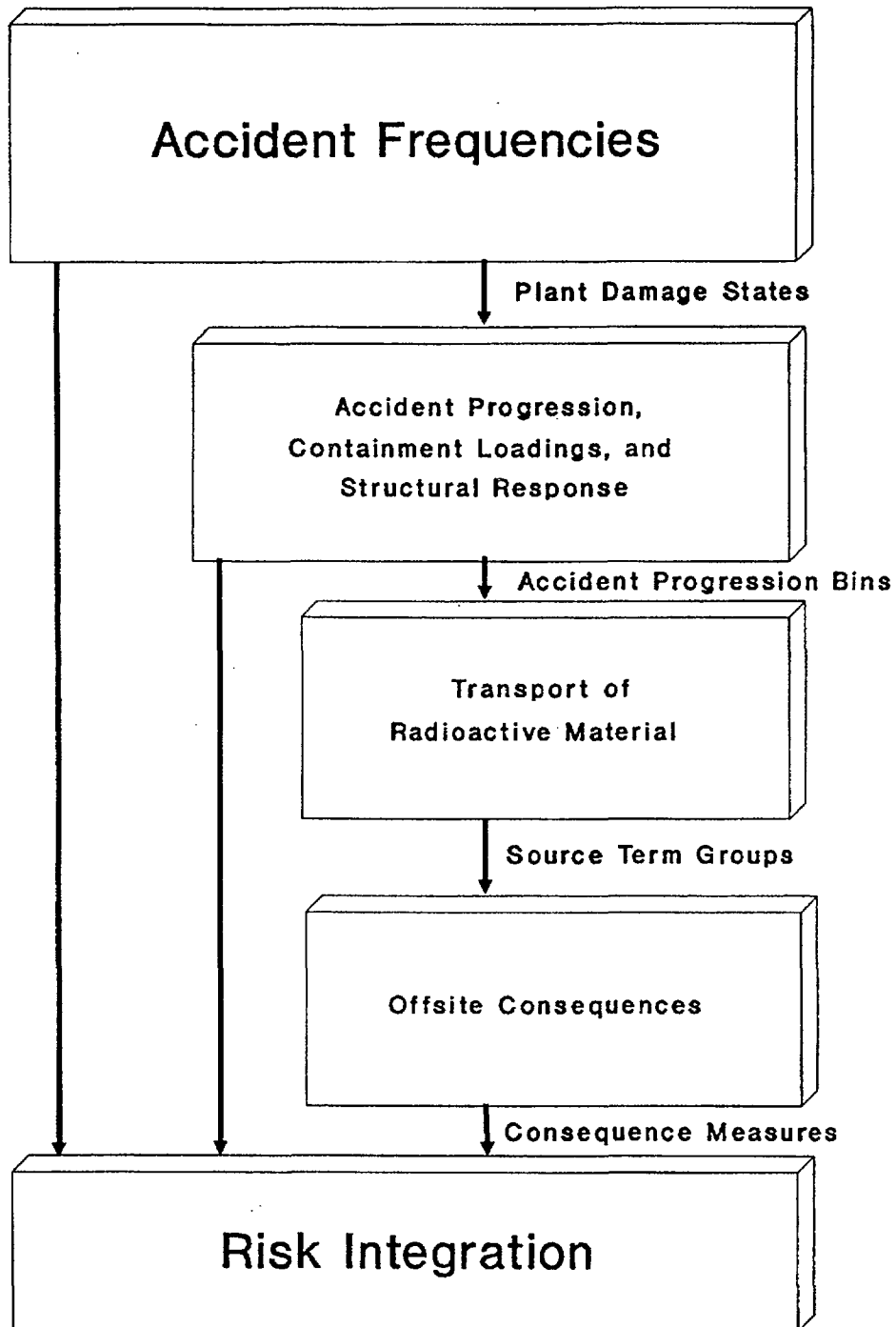

Figure 2.1 Elements of risk analysis process.

Table 2.1 Definition of some key NUREG-1150 risk analysis terms.

Core Damage Frequency: The frequency of combinations of initiating events, hardware failures, and human errors leading to core uncover with reflooding of the core not imminently expected. For the pressurized water reactors (PWRs) discussed in this report, it was assumed that onset of core damage occurs at uncover of the top of the active fuel (without imminent recovery). For the boiling water reactors (BWRs) discussed in this report, it was assumed that onset of core damage would occur when the water level was less than 2 feet above the bottom of the active fuel (without imminent recovery). (Ref. 2.1 discusses the reasons for the BWR/PWR differences.)

Internal Initiating Events: Initiating events (e.g., transient events requiring reactor shutdown, pipe breaks) occurring during the normal power generation of a nuclear power plant. In keeping with PRA tradition, loss of offsite power is considered an internal initiating event.

External Initiating Events: Events occurring away from the reactor site that result in initiating events in the plant. In keeping with PRA tradition, some events occurring within the plant during normal power plant operation, e.g., fires and floods initiated within the plant, are included in this category.

Plant Damage State: A group of accident sequences that has similar characteristics with respect to accident progression and containment engineered safety feature operability.*

Accident Progression Bin: A group of postulated accidents that has similar characteristics with respect to (for this summary report) the timing of containment building failure and other factors that determine the amount of radioactive material released.* These are analogous to containment failure modes used in previous PRAs.

Early Containment Failure: Those containment failures occurring before or within a few minutes of reactor vessel breach for PWRs and those failures occurring before or within 2 hours of vessel breach for BWRs. Containment bypass failures (e.g., interfacing-system loss-of-coolant accidents) are categorized separately from early failures.

Source Term: The fractions defining the portion of the radionuclide inventory in the reactor at the start of an accident that is released to the environment. Also included in the source term are the initial elevation, energy, and timing of the release.

Source Term Group: A group of releases of radioactive material that has similar characteristics with respect to the potential for causing early and latent cancer fatality consequences and warning times.

Offsite Consequences: The effects of a release of radioactive material from the power plant site, measured (for this summary report) as the number of early fatalities in the area surrounding the site and within 1 mile of the site boundary, latent cancer fatalities in the area surrounding the site and within 10 miles of the power plant, and population dose in the area surrounding the site and within 50 miles of the power plant.

Probability Density Function: The derivative of the cumulative distribution function. A function used to calculate the probability that a random variable (e.g., amount of hydrogen generated in a severe accident) will fall in a given interval. That probability is proportional to the height of the distribution function in the given interval.

Cumulative Distribution Function: The cumulative distribution function gives the probability of a parameter being less than or equal to a specified value. The *complementary cumulative distribution function* gives the probability of a parameter value being equal to or greater than a specified value.

*Groupings of this sort can be made in a variety of ways; the contractor reports underlying this report provide more detailed groups (Refs. 2.3 through 2.7 and 2.10 through 2.14).

2. Summary of Methods

reader is cautioned that an estimated mean may vary by about a factor of two because of sample variation. This variation can also impact the relative contribution of factors (e.g., plant damage states) to the mean (particularly small contributions).

In many risk analyses, "best estimate" analyses are performed. For these studies, many input parameters, even highly uncertain ones, are represented by single "best" values rather than probability distributions as done in this study. The resulting estimate of risk calculated with such best estimate parameter values is not simply related to the mean, median, or any other value of the distributions of risk calculated in this study.

As is implicit in Figure 2.1, the five principal risk analysis parts have clearly defined interfaces through which summary information passes to and from the constituent parts of the analysis and which provide convenient intermediate results for examination and review. Such summary information will be provided in this report; the form of the information presented will be described in the following sections.

2.2 Accident Frequency Estimation

The accident frequency estimation methods underlying this report considered accidents initiated by events occurring during the normal full-power generation* of a nuclear power plant ("internal events") and those initiated by events occurring away from the plant site ("external events"). (Historically, accidents initiated by loss of offsite power have been included in the category of internal events, while fires and floods within the plant during normal operation have been included in the category of external events. This tradition is continued in this report.) The discussion below summarizes accident frequency estimation methods first for internally initiated accidents, followed by those for externally initiated accidents.

2.2.1 Methods

2.2.1.1 Internal-Event Methods

The first part of the analysis shown in Figure 2.1 ("Accident Frequencies") represents the estimation of the frequencies of accident sequences leading to core damage. In this portion of the analysis, combinations of potential accident initiating events (e.g., a pipe break in the reactor coolant system) and system failures that could result in core damage are defined and frequencies

*Accidents initiated in non-full-power operation are the subject of ongoing study for the Surry and Grand Gulf plants.

of occurrence calculated. The methods for performing this analysis are discussed in Appendix A and in considerable detail in Reference 2.1. In summary, the basic steps in this analysis are:

- *Plant Familiarization:* In this step, information is assembled from plant documentation using such sources as the Final Safety Analysis Report, piping and instrumentation diagrams, technical specifications, operating procedures, and maintenance records, as well as a plant site visit to inspect the facility, gather further data, and clarify information with plant personnel. Regular contact is maintained with the plant personnel throughout the study to ensure that current information is used. The analyses discussed in this report reflect each plant's status as of approximately March 1988. This step of the accident frequency analysis was performed in a manner typical of recent PRAs (e.g., as described in Ref. 2.15).
- *Accident Sequence Initiating Event Analysis:* Information is assembled on the types of accident initiating events of potential interest for the specific plant. The initiating events identified include those that could result from support system failures, such as electric power or cooling water faults. Frequencies of initiating events are then assessed. In some cases, the assessed frequencies of certain events were very low; such events were not carried forward into the remaining analysis. Then, the safety functions required to prevent core damage for the individual initiating events are identified, along with specific plant systems required to perform those safety functions, the systems' success criteria (e.g., how much water flow is required from a pumping system), and related operating procedures. The initiating events are then grouped based upon the similarity of response needed from the various plant systems. This step of the analysis was performed in a manner typical of recent PRAs.
- *Accident Sequence Event Tree Analysis:* Using information from the previous step, system event trees that display the combinations of plant system failures that can result in core damage are constructed for each initiating event group. An individual path through such an event tree (an accident sequence) identifies specific combinations of system successes and failures leading to (or avoiding) core damage. As such, the event tree qualitatively identifies what systems must fail in a plant in order to cause core damage (the associated

system failure probabilities are obtained in following steps). This step of the analysis was performed in a more advanced manner relative to other recent PRAs. For example, the analyses supporting this report considered a significantly greater number of systems in the event trees, including the potential effects on core damage processes from failures of containment functions and systems.

- *Systems Analysis:* In order to estimate the frequencies of accident sequences, the failure probability of each system must be obtained. The important contributors to failure of each system are defined using fault tree analysis methods. Such methods allow the analyst to identify the ways in which system failure may occur, assign failure probabilities to individual plant components (e.g., pumps or valves) and human actions related to the system's operation, and combine the failure probabilities of individual components into an overall system failure probability. This step was performed in a manner typical of that of recent PRAs. The level of detail was determined by the system's relative importance to core damage frequency, based on screening assessments and perspectives from other studies and PRAs.*
- *Dependent and Subtle Failure Analysis:* In addition to the combining of individual component failures, plant systems can fail as a result of the failure of multiple components due to a common cause. Such "dependent failures" may be separated into two types. First, there are direct functional dependencies that can lead to failure of multiple components (e.g., lack of electric power from emergency diesel generators causing failure of emergency core cooling systems). Such dependencies are incorporated directly into the fault or event trees. Second, there are dependent failures that have been experienced in plant operations due to less direct causes and often for which no direct causal relationships have been found. Various methods exist for incorporating such "miscellaneous" failures into the quantification of system fault trees. For this study, a modified "beta factor" method was used (Ref. 2.17). This step of the accident frequency analysis was performed in greater depth than that of

typical recent PRAs, in that considerable effort was devoted to generating beta factors for multiple failures (i.e., more than two) using recent advances in common-cause analytical methods. In addition, a subtle failure "checklist" was developed and used. This checklist defined subtle failures found in previous PRAs.

- *Human Reliability Analysis:* As noted in previous steps, explicit consideration of human error was included in the analysis. Errors of two types were incorporated: pre-accident errors, including, for example, failure to properly return equipment to service after maintenance; and post-accident initiation errors, including failure to properly diagnose or respond to and recover from accident conditions. In order to assess failure probabilities for such events, operating procedures for the specific plant under study were obtained and reviewed. In general, the analysis of such errors was made using methods typical of recent PRAs (i.e., modifications of the "THERP" method (Ref. 2.18)) but at a somewhat reduced level of effort. An initial screening analysis was performed to focus the analysis to the potentially most important operator actions (including recovery actions), permitting some savings of effort. More detailed analyses were performed for the BWR anticipated transient without scram (ATWS) accident sequences (Refs. 2.6 and 2.19).
- *Data Base Analysis:* In general, a common data base of equipment and human failure rates and initiating event frequencies was used in the five plant risk analyses, based on operating experience in all commercial nuclear power plants (Ref. 2.1). In addition, the operating experience of each plant studied for this report was examined for relevant failure data on key systems and equipment. The "generic" data base (from all plants) was then replaced with plant-specific data (if available) for these key components in cases where the plant-specific data were significantly different. The methods used to obtain and apply plant-specific data were typical of those of recent PRAs; however, the level of effort expended was less than that generally performed because of limitations in the original analysis scope and, in some cases, because a plant's operating life had been too short to generate an adequate data base.
- *Accident Sequence Quantification Analysis:* In this step, the information from the

*The reader is cautioned that the level of analysis detail and screening assessments used for systems in this study was based on the designs of each of the plants. Thus, it should not be inferred that the results of such assessments necessarily apply to other plants.

2. Summary of Methods

preceding steps was assembled into an assessment of the frequencies of individual accident sequences, using the fault trees and event trees to combine probabilities of individual events. This was performed in a manner typical of recent PRAs.

- *Plant Damage State Analysis:* In order to assist the analysis of the physical processes of core damage accidents (i.e., the subsequent steps in a risk analysis), it is convenient to group the various combinations of events comprising the accident sequences into "plant damage states." These states are defined by the operability of plant systems (e.g., the availability of containment spray systems) and by certain key physical conditions in an accident (e.g., reactor coolant system pressure). The definition of the plant damage states and the associated frequencies are the principal products provided to the next step in the risk analysis, i.e., the analysis of accident progression, containment loadings, and structural response. This step was performed in a manner more advanced than most recent PRAs because of the complexity of the interface with the more detailed accident progression analysis.
- *Uncertainty Analysis and Expert Judgment:* As noted in Section 2.1, the risk analyses underlying this report include the quantitative analysis of uncertainties. This analysis was performed using the Latin hypercube sampling technique (Ref. 2.20), a specialized modification of Monte Carlo simulation tech-

niques often used in the combination of uncertainties. The elicitation of expert judgments was necessary to develop the probability distributions for some individual parameters in this uncertainty analysis. For certain key issues in the uncertainty analysis, panels of experts were convened to discuss and help develop the needed probability distributions. The methods used for uncertainty analysis and expert judgment elicitation are discussed in Sections 2.6 and 2.7. For the accident frequency analysis, six issues were evaluated by two expert panels and probability distributions developed; these issues are shown in Table 2.2. Probability distributions were developed for many other parameters as well. Section C. 1 of Appendix C includes a listing of the set of accident frequency issues assigned distributions for the Surry plant. Similar lists for the other plants may be found in References 2.11 through 2.14.

Appendix B provides a detailed example calculation for a particular accident (a station blackout) at the Surry plant. Section B.2 of that appendix describes the analysis of the accident sequence frequency.

It should be noted that the methods used in the accident frequency analysis of the Zion plant varied from those described above. A PRA was completed for this plant by the licensee (Commonwealth Edison Company) in 1981 (Ref. 2.21). This PRA was subsequently reviewed by the NRC staff and its contractors (Ref. 2.22), with the review completed in 1985. For the Zion accident

Table 2.2 Accident frequency analysis issues evaluated by expert panels.

| |
|--|
| • Accident Frequency Analysis Panel |
| Failure probabilities for check valves in the quantification of interfacing-system LOCA frequencies (PWRs) |
| Physical effects of containment structural or vent failures on core cooling equipment (BWRs) |
| Innovative recovery actions in long-term accident sequences (PWRs and BWRs) |
| Pipe rupture frequency in component cooling water system (Zion) |
| Use of high-pressure service water system as source for drywell sprays (Peach Bottom) |
| • Reactor Coolant Pump Seal Performance Panel |
| Frequency and size of reactor coolant pump seal failures (PWRs) |

frequency analysis summarized in this report, this previous PRA (as modified by the 1985 staff review) was updated to reflect the plant design and operational features in place in early 1988. As such, the Zion accident frequency analysis relied substantially on the previous PRA, rather than performing a new study.

The methods used to perform the Zion accident frequency analysis are discussed in greater detail in Section A.2.2 of Appendix A and in Reference 2.7.*

2.2.1.2 External-Event Methods

The analysis of accident frequencies for the Surry and Peach Bottom plants included the consideration of accidents initiated by external events (e.g., earthquakes, floods, fires) (Refs. 2.3 and 2.4). The methods used to perform these analyses are more efficient versions of previous methods and are described in Section A.2.3 of Appendix A and in more detail in Reference 2.23.

1. External-Event Methods: Seismic Analysis

The seismic analysis methods performed for this study consisted of seven steps. Briefly, these are:

- *Determination of Site Earthquake Hazard:* The seismic analyses in this report made use of two data sources on the frequency of earthquakes of various intensities at the specific plant site (the seismic "hazard curve" for that site): the "Eastern United States Seismic Hazard Characterization Program," funded by the NRC at Lawrence Livermore National Laboratory (LLNL) (Ref. 2.24); and the "Seismic Hazard Methodology for the Central and Eastern United States Program," sponsored by the Electric Power Research Institute (EPRI) (Ref. 2.25). In both the LLNL and EPRI programs, seismic hazard curves were developed for all U.S. commercial power plant sites east of the Rocky Mountains using expert panels to interpret available data. The NRC staff presently considers both program results to be equally valid (Ref. 2.26). For this reason, two sets of seismic results are provided in this

report. Section C.11 of Appendix C discusses the analysis of seismic hazards in more detail.

- *Identification of Accident Sequences:* The scope of the seismic analysis included loss-of-coolant accidents (LOCAs) (i.e., pipe ruptures of a spectrum of sizes including vessel rupture) and transient events. Two types of transient events were considered: those in which the power conversion system (PCS) was initially available and those in which the PCS failed as a direct consequence of the initiating event. The event trees developed in the internal-event analyses (described above) were also used to define seismically initiated accident sequences.
- *Determination of Failure Modes:* The internal-event fault trees (described above) were used in the seismic analysis, with some modification, to specify the failure modes of components, combinations of which resulted in plant system failures.
- *Determination of Fragilities:* Component seismic fragilities were obtained both from a generic fragility data base and from plant-specific fragilities estimated for components identified during a plant visit.

The generic data base of fragility functions for seismically induced failures was originally developed as part of the Seismic Safety Margins Research Program (SSMRP) (Ref. 2.27). In that program, fragility functions for the generic categories were developed based on a combination of experimental data, design analysis reports, and an extensive survey of expert judgments, providing probability distributions of fragilities.

Detailed fragility analyses were performed for all important structures at the studied plants. In addition, an analysis of liquefaction for the underlying soils was performed.

- *Determination of Seismic Responses:* Building and component seismic peak ground acceleration responses were computed using dynamic building models and time history analysis methods. Results from the SSMRP analysis of the Zion plant (Ref. 2.28) and methods studies (Ref. 2.23) formed the basis for assessing uncertainties in responses.
- *Computation of Core Damage Frequency:* Given the input from the five steps above, the frequencies of accident sequences, plant damage states, and core damage were

*The analysis of accident progression, containment loadings, and structural response; radioactive material transport; offsite consequences; and integrated risk for the Zion plant did not rely significantly on the previous PRA, but was essentially identical (in methods used) to the other four plant studies performed for this report.

2. Summary of Methods

calculated in a manner like that described above for the internal-event accident frequency analysis.

- *Estimation of Uncertainty:* The frequency distributions of individual parameters in the seismic analysis, as developed in the previous steps, were combined to yield frequency distributions of accident sequences, plant damage states, and total core damage. This process was performed using Monte Carlo techniques.

2. External-Event Methods: Fire Analysis

There were four principal steps in the fire accident frequency analysis methods used for this report. Briefly, these are:

- *Initial Plant Visit:* Based on the internal-event and seismic analyses, the general location of cables and components of the principal plant systems had previously been developed. A plant visit was then made to permit the analysis staff to see the physical arrangements in each of these areas. The analysis staff had a fire zone checklist to aid in the screening analysis and in the quantification step (described below).

Another purpose of the initial plant visit was to confirm with plant personnel that the documentation being used was in fact the best available information and to obtain answers to questions that might have arisen in a review of the documentation. As part of this, a thorough review of firefighting procedures was conducted.

- *Screening of Potential Fire Locations:* It was necessary to select fire locations within the power plant under study that had the greatest potential for producing accident sequences of high frequency or risk. The selection of fire locations was performed using a screening analysis, which identified potentially important fire zones and prioritized these zones based on the frequencies of fire-induced initiating events in the zone and the probabilities of subsequent failures of important equipment.
- *Accident Sequence Quantification:* After the screening analysis had eliminated all but the probabilistically significant fire zones, detailed quantification of dominant accident sequences was completed as follows:

- Determination of the temperature response in each fire zone;
- Computation of component fire fragilities;
- Assessment of the probability of barrier failure for the remaining combinations of fire zones; and
- Performance of operator recovery analyses (like that described above for internal-event analyses).

- *Uncertainty Analysis:* This quantification was performed using Monte Carlo techniques like those discussed above for the internal-event analysis. No expert panels were directly used to support the development of probability distributions. Distributions for needed data were developed by the analysis staff using operating experience and experimental results.

3. External-Event Methods: Other Initiating Events

In addition to the seismic and fire external-event analyses, bounding analyses were performed for other external events that were judged to potentially contribute to the estimated plant risk. Those events that were considered included extreme winds and tornadoes, turbine missiles, internal and external flooding, and aircraft impacts.

Conservative probabilistic models were initially used in these bounding analyses. If the mean initiating event frequency resulting from such an analysis was estimated to be low (e.g., less than $1E-6$ per year), the external event was eliminated from further consideration. Using this logic, the bounding analyses identified those external events in need of more study.

2.2.2 Products of Accident Frequency Analysis

The accident frequency analyses performed in this study can be displayed in a variety of ways. The specific products shown in this summary report are:

- The total core damage frequency from internal events and, where estimated, for external events.

For Part II of this report (plant-specific results), tabular data and a histogram-type plot are used to represent the distribution of total core damage frequency. This histogram displays the fraction of Latin hypercube

sampling (LHS) observations falling within each interval.* Figure 2.2 displays an example histogram (on the right side of the figure). Four measures of the probability distribution are identified in Figure 2.2 (and throughout this report):

- Mean (arithmetic average or expected value);
- Median (50th percentile value);
- 5th percentile value; and
- 95th percentile value.

In some circumstances, the calculated probability distributions extend to very small values. When this occurs, the staff has chosen to group together all observations below a specific value. This grouped set of observations is displayed apart from (but on the same figure as) the probability distribution.

A second display of accident frequency results is used in Part III of this report, where results for all five plants are displayed together. This rectangular display (shown on the left side of Fig. 2.2) provides a summary of these four specific measures in a simple graphical form.

For those plants in which both internal and external events have been analyzed (Surry and Peach Bottom), the core damage frequency results are provided separately for internal, seismic, and fire accident initiators.

The NRC-sponsored review of the second draft of this report includes some cautions on the interpretation of low accident frequencies (Ref. 2.29). These cautions are noted on appropriate figures throughout the remainder of this report.

- The definitions and estimated frequencies of plant damage states.

The total core damage frequency estimates described above are the sum of the frequencies of various types of accidents. For this

*Care should be taken in using these histograms to estimate probability density functions. These histogram plots were developed such that the heights of the individual rectangles were not adjusted so that the rectangular areas represented probabilities. The shape of a corresponding density function may be very different from that of the histogram. The histograms represent the probability distribution of the logarithm of the core damage frequency.

summary report, the total core damage frequency has been divided into the contributions of plant damage states such as:**

- Loss of all ac electric power (station blackout);
- Transient events with failure of the reactor protection system (ATWS events);
- Other transient events;
- LOCAs resulting from reactor coolant system pipe ruptures, reactor coolant pump seal failures, and failed relief valves occurring within the containment building; and
- LOCAs that bypass the containment building (steam generator tube ruptures and interfacing-system LOCAs).

Figure 2.3 is an example display of these results. In this figure, a pie chart is used to display the mean value of the total core damage frequency distribution for each of these plant damage states.

In addition to these quantitative displays, the results of the accident frequency analyses also can be discussed with respect to the qualitative perspectives obtained. In this summary report, qualitative perspectives are provided in two levels:

- *Important Plant Characteristics:* The discussion of important plant characteristics focuses on general system design and operational aspects of the plant. Perspectives are thus provided on, for example, the design and operation of the emergency diesel generators, or the capability for the "feed and bleed" mode of emergency core cooling. These results are provided in Section 3.2.2 of Chapter 3 and like numbered sections in Chapters 4 through 7.
- *Measures of Importance of Individual Events:* One typical product of a PRA is a set of "importance measures." Such measures are used to assess the relative importance of individual items (such as the failure rates of

**Plant damage states were defined in these risk analyses at two levels. "Summary" plant damage states were defined for use in this report and were created by combining much more detailed damage states that consider more specific types of failures and convey much more detailed information to the accident progression analysis. These more detailed plant damage states were used in the actual risk calculations. An example of the level of detail may be found in Appendix B; the contractor reports underlying this report provide and discuss the complete set of plant damage states for all plants (Refs. 2.3 through 2.7 and 2.10 through 2.14).

Frequency (per reactor year)

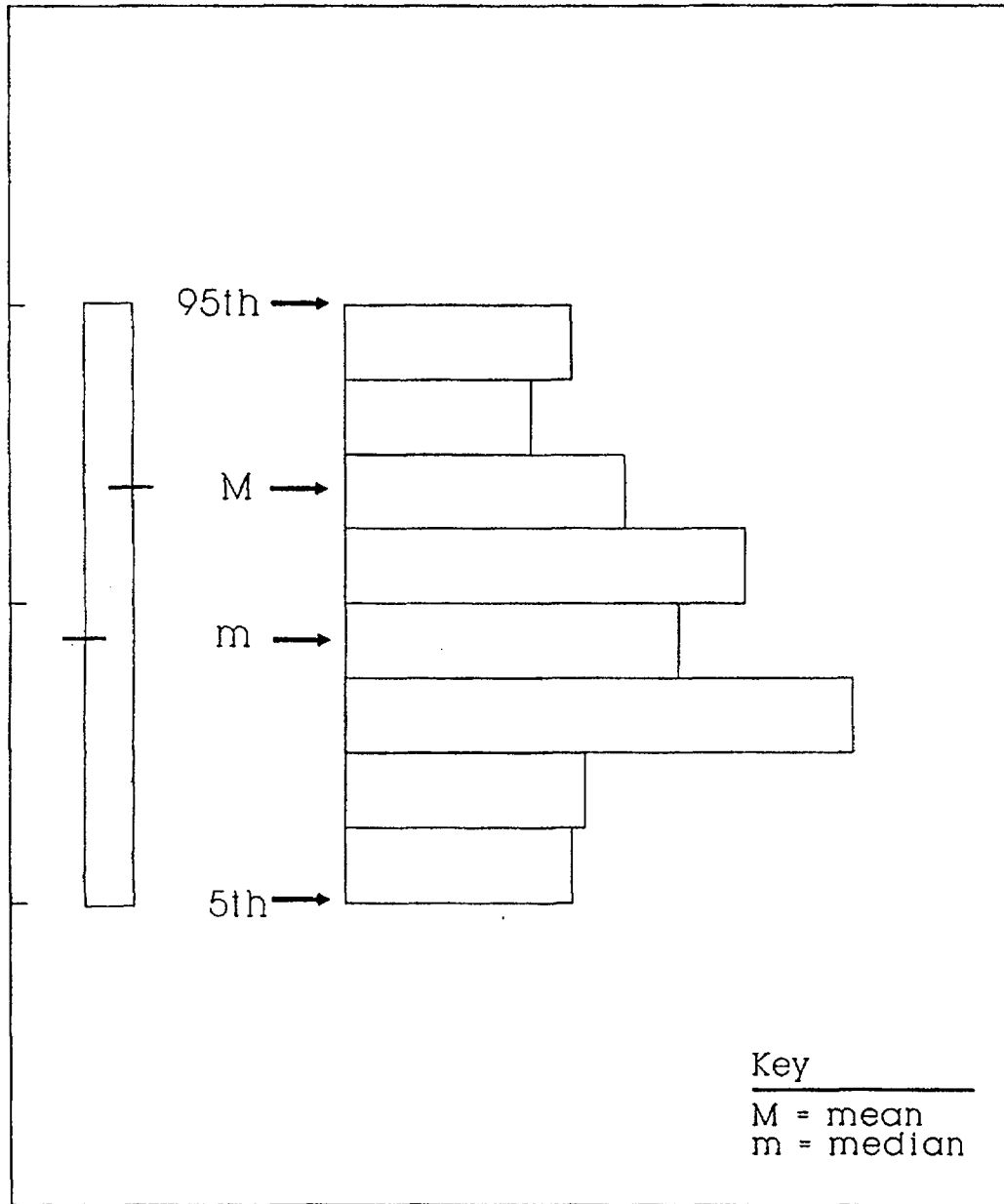

Figure 2.2 Example display of core damage frequency distribution.

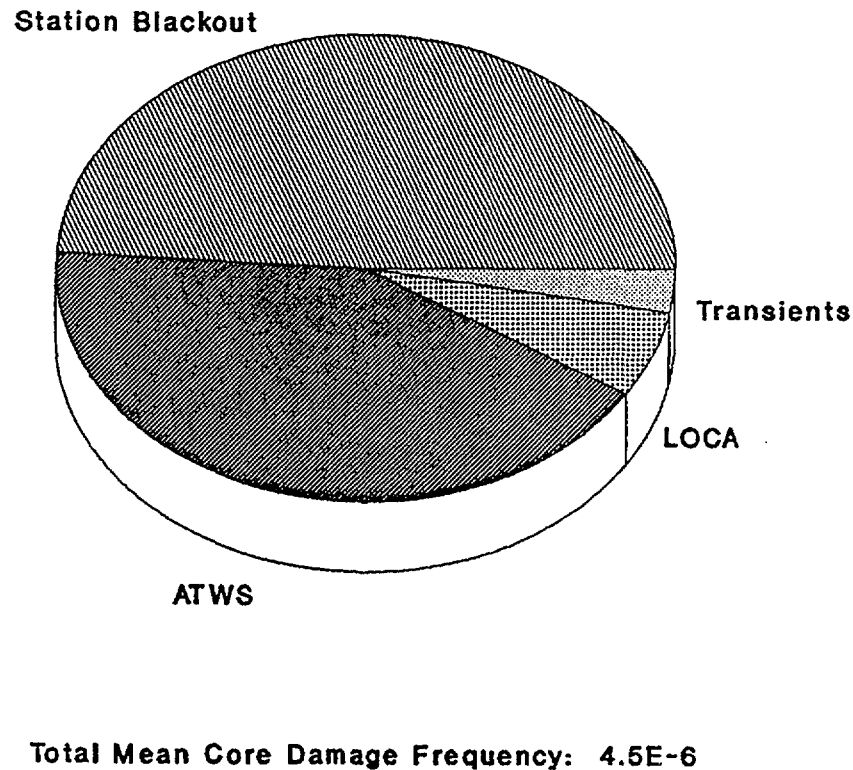

Figure 2.3 Example display of mean plant damage state frequencies.

individual plant components or the uncertainties in such failure rates) to the total core damage frequency. While a variety of measures exist, two are discussed (qualitatively) in this summary report. The first measure shows the effect of significant reductions in the frequencies of individual plant component failures or plant events (e.g., loss of offsite power, specific human errors) on the total core damage frequency. In effect, this measure shows how to most effectively reduce core damage frequency by reducing the frequencies of these individual events. The second importance measure discussed in this summary report indicates the relative contribution of key uncertainty distributions to the uncertainty in total core damage frequency. In effect, this measure shows how most effectively to reduce the uncertainty in core damage frequency by reductions in the uncertainty in individual events. These results are provided in Section 3.2.4 of Chapter 3 and like numbered sections in Chapters 4 through 7.

2.3 Accident Progression, Containment Loading, and Structural Response Analysis

2.3.1 Methods

The second part of the risk analysis process shown in Figure 2.1 ("Accident Progression, Containment Loading, and Structural Response") is the analysis of the progression of the accident after the core has begun to degrade. For each general type of accident, defined by the plant damage states, the analysis considers the important characteristics of the core melting process, the challenges to the containment building, and the response of the building to those challenges. Event trees were used to organize and quantify the large amounts of information used in this analysis. The event trees combined information from many sources, e.g., detailed computer accident simulations and panels of experts providing interpretations of available data.

2. Summary of Methods

In summary, the principal steps of the accident progression analysis are:

- *Development of Accident Progression Event Trees:* Accident progression event trees were used in this study to identify, sequentially order, and probabilistically quantify the important events in the progression of a severe accident. The development of an accident progression event tree consisted of identifying potentially important parameters to the accident progression and associated containment building structural response, determining possible values of each parameter (including dependencies on outcomes of previous parameters in the event tree), ordering the events chronologically, and defining the information needed to determine each parameter. The information base used consisted of accident and experimental data and calculational results from accident simulation computer codes, analyses of containment building structures, etc.* While the event tree development process used for this study is conceptually similar to that of other PRAs, both the complexity of the tree (the number of parameters and possible outcomes) and the supporting data base developed were substantially greater than those of other recent PRAs, so that more explicit use could be made of severe accident experimental and calculational information (additional discussion of the supporting data base is provided below).
- *Probabilistic Quantification of Event Trees:* Using the event tree structure and information base developed in the previous step, probability distributions for the most uncertain parameters in the accident progression event tree were generated in this step. As is typical of any PRA, this assignment of values was subjective, based on the interpretation of the data base by the risk analyst. For instance, the applicable data base is sometimes conflicting. The choice of which data to emphasize and use is a matter of each analyst's judgment, based on personal experience and familiarity. However, for this study, both the degree to which experts in accident analysis were used and the degree of documentation of the rationale for the probability distribu-

tions used were significantly greater than in other recent PRAs (additional discussion of the supporting data base is provided below).

- *Grouping of Event Tree Outcomes:* Accident progression event trees such as those constructed for this study produce a large set of alternative outcomes of a severe accident. As is typically done in PRAs, these outcomes were grouped into a smaller set of "accident progression bins." For this summary report, bins were defined principally according to the timing of containment building failure. This summary set of accident progression bins is subdivided into bins of greater detail in the supporting contractor reports (Refs. 2.10 through 2.14).

As noted above, the accident progression event trees developed for this study made extensive use of the available severe accident experimental and calculational data bases. The analysis staff made use of calculational results from a number of accident simulation computer codes, including the Source Term Code Package (Ref. 2.30), CONTAIN (Ref. 2.31), MELCOR (Ref. 2.32), and MELPROG (Ref. 2.33).

To support the analysis of certain key issues in the accident progression analysis, expert panels were convened. Fourteen accident progression, containment loadings, and structural response issues were considered by four panels, as shown in Table 2.3. These panels considered a wide range of information available from experiments and computer calculations. Using expert elicitation methods summarized in Section 2.7, probability distributions were developed based on the experts' interpretations of these issues. In addition to this set of key issues, probability distributions were developed for many other issues. Section C.1 of Appendix C provides a listing of such issues, using the Surry plant as an example. Similar listings for the other plants may be found in References 2.11 through 2.14.

Additional discussion of the methods used to develop and quantify the accident progression event trees may be found in Section A.3 of Appendix A. Reference 2.8 provides an extensive discussion of the methods used, suitable for the reader expert in severe accident and risk analysis.

Section B.3 of Appendix B provides a detailed example calculation showing how the accident progression analysis methods summarized above were used in the risk analyses supporting this report.

*In the accident progression analysis of seismic-initiated accidents, some additional loads on containment structures are considered for high-intensity earthquakes (e.g., structural loads resulting from motion of piping).

Table 2.3 Accident progression and containment structural issues evaluated by expert panels.

-
- In-Vessel Accident Progression Panel
 - Probability of temperature-induced reactor coolant system hot leg failure (PWRs)
 - Probability of temperature-induced steam generator tube failure (PWRs)
 - Magnitude of in-vessel hydrogen generation (PWRs and BWRs)
 - Mode of temperature-induced reactor vessel bottom head failure (PWRs and BWRs)
 - Containment Loadings Panel
 - Containment pressure increase at reactor vessel breach (PWRs and BWRs)
 - Probability and pressure of hydrogen combustion before reactor vessel breach (Sequoyah and Grand Gulf)
 - Probability and effects of hydrogen combustion in reactor building (Peach Bottom)
 - Molten Core-Containment Interactions Panel
 - Drywell shell meltthrough (Peach Bottom)
 - Pedestal erosion from core-concrete interaction (Grand Gulf)
 - Containment Structural Performance Panel
 - Static containment failure pressure and mode (PWRs and BWRs)
 - Probability of ice condenser failure due to hydrogen detonation (Sequoyah)
 - Strength of reactor building (Peach Bottom)
 - Probability of drywell and containment failure due to hydrogen detonation (Grand Gulf)
 - Pedestal strength during concrete erosion (Grand Gulf)
-

2.3.2 Products of Accident Progression, Containment Loading, and Structural Response Analysis

The product of the accident progression and containment loading analysis is a set of accident progression bins. Each bin consists of a group of postulated accidents (with associated probabilities for each plant damage state) that has similar outcomes with respect to the subsequent portion of the risk analysis, analysis of radioactive material transport. As such, the accident progression bins are analogous to the plant damage states described in Section 2.2.1, in that they are defined based on their impact on the next analysis part. Quantitatively, the product consists of a matrix of conditional probabilities (as shown in Fig. 2.4*), with the rows and columns defined by the sets of

plant damage states and accident progression bins, respectively. The matrix defines the probabilities that an accident will have an outcome characteristic of a given accident progression bin if the accident began as one having the characteristic of a given plant damage state.

In this summary report, products of the accident progression analysis are shown in the following ways:

- The distribution of the probability of early containment failure** for each plant damage state.

An example display of early containment failure probability is provided in Figure 2.5.* As may be seen, the probability distribution is represented by a histogram like that discussed above for core damage frequency.

*The mean plant damage state frequencies shown in Figures 2.4 and 2.5 (and like figures in Chapters 3 through 7) may be somewhat different from those shown in tables such as Table 3.2. The data in the latter tables resulted from uncertainty analyses using a large number of variables. The frequencies shown in the figures resulted from the uncertainty analysis of only the key accident frequency issues included in the integrated task analysis.

**In this report, early containment failure includes failures occurring before or within a few minutes of reactor vessel breach for pressurized water reactors and those failures occurring before or within 2 hours of vessel breach for boiling water reactors. Containment bypass failures are categorized separately from early failures.

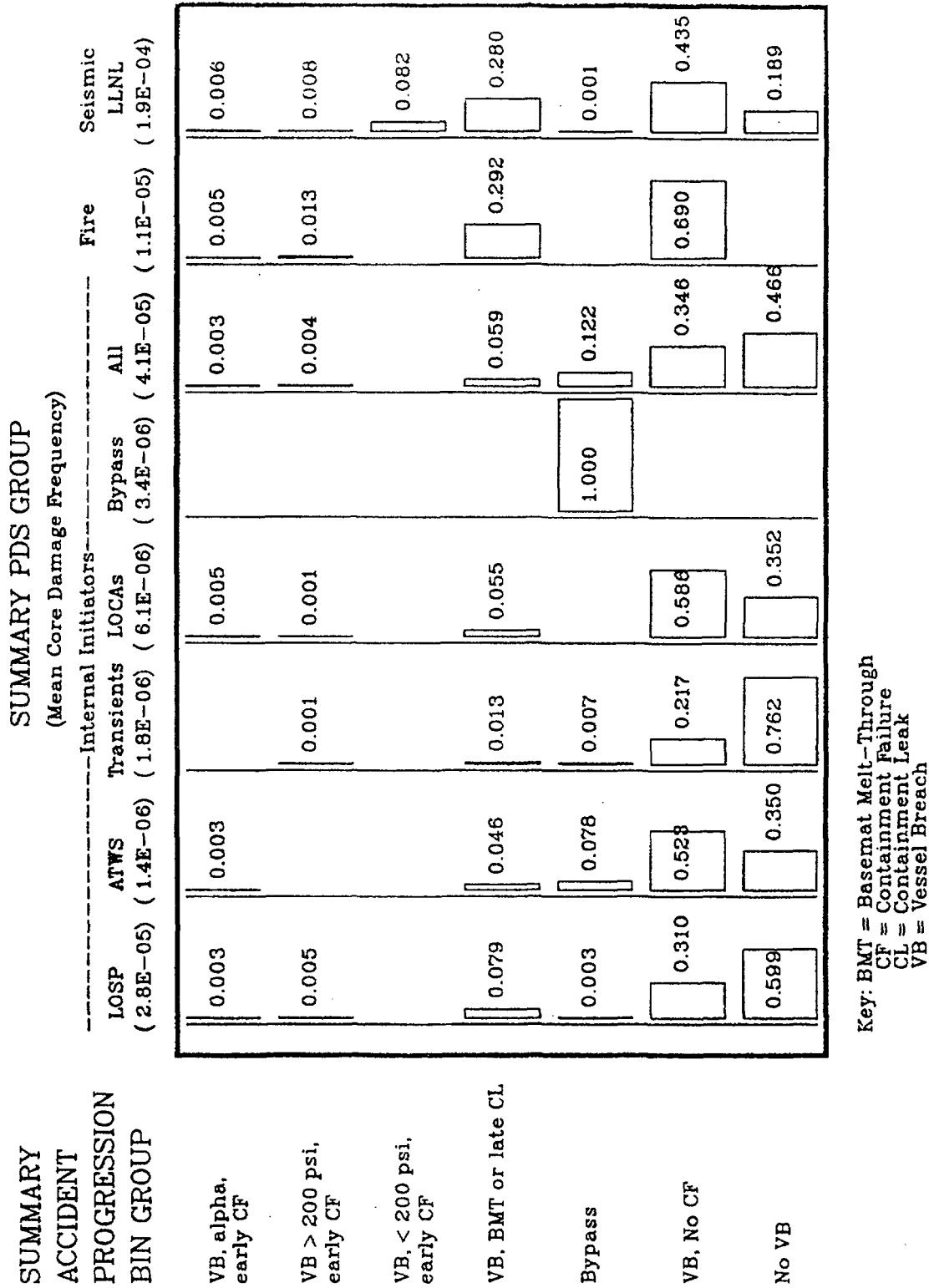

Figure 2.4 Example display of mean accident progression bin conditional probabilities.

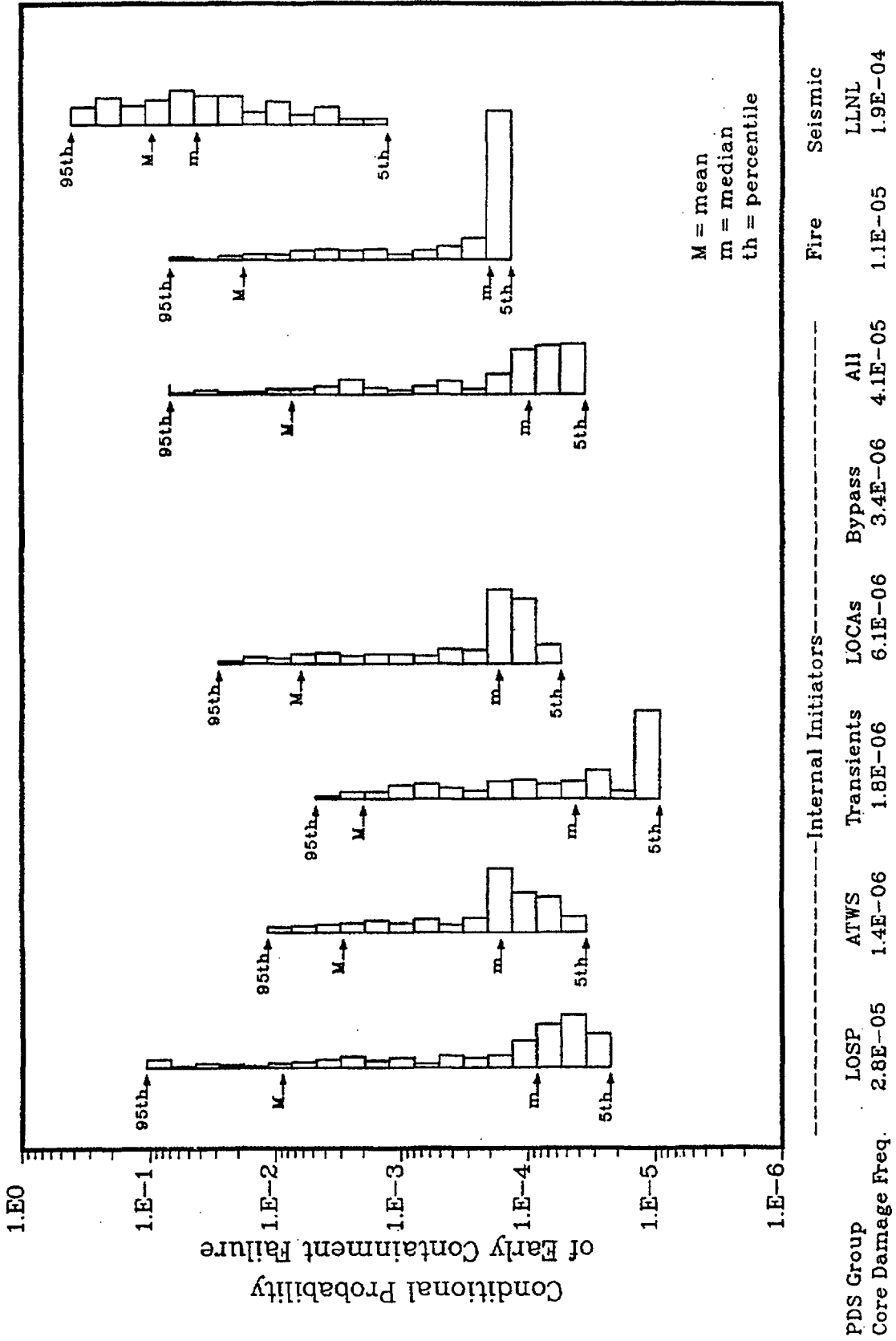

Figure 2.5 Example display of early containment failure probability distribution.

2. Summary of Methods

Measures of this distribution provided include:

- Mean;
 - Median;
 - 5th percentile value; and
 - 95th percentile value.
- The mean conditional probability of each accident progression bin for each plant damage state.

Figure 2.4 displays example results of the mean conditional probability of each accident progression bin for each plant damage state. Results are provided both in tabular and graphical (bar chart) forms.

2.4 Analysis of Radioactive Material Transport

2.4.1 Methods

The radioactive material transport analysis tracks the transport of the radioactive materials from the fuel to the reactor coolant system, then to the containment and other buildings, and finally into the environment. The fractions of the core inventory released to the atmosphere, and the timing and other release information needed to calculate the offsite consequences, together are termed the "source term." The removal and retention of radioactive material by natural processes, such as deposition on surfaces, and by engineered sys-

tems, such as sprays, are accounted for in each location.

Briefly, the principal steps in this analysis include:

- *Development of Parametric Models of Material Transport:* Because of the complexity and cost of radioactive material transport calculations performed with detailed codes, the number of accidents that could be investigated with these codes was rather limited. Further, no one detailed code available for the analyses contained models of all physical processes considered important to the risk analyses. Therefore, source terms for the variety of accidents of interest were calculated using simplified algorithms. The source terms were described as the product of release fractions and transmission factors at successive stages in the accident progression for a variety of release pathways, a variety of accident progressions, and nine classes of radionuclides. The release fraction at each stage of the accident and for each pathway is determined using various information such as predictions of detailed mechanistic codes, experimental data, etc. For the more important release parameters, listed in Table 2.4, probability distributions were developed by a panel of experts. The set of codes (one for each plant) used to calculate the source terms is known collectively as the "XSOR" codes (Ref. 2.34). The XSOR codes are parametric in nature; that is, they are designed to use the results of more detailed mechanistic codes or analyses as input.

Table 2.4 Source term issues evaluated by expert panel.

| |
|--|
| • Source Term Expert Panel |
| In-vessel retention and release of radioactive material (PWRs and BWRs) |
| Revolatization of radioactive material from the reactor vessel and reactor coolant system (early and late) (PWRs and BWRs) |
| Radioactive releases during high-pressure melt ejection/direct containment heating (PWRs and BWRs) |
| Radioactive releases during core-concrete interaction (PWRs and BWRs) |
| Retention and release from containment of core-concrete interaction radioactive releases (PWRs and BWRs) |
| Ice condenser decontamination factor (Sequoyah) |
| Reactor building decontamination factor (Grand Gulf) |
| Late sources of iodine (Grand Gulf) |

Release terms are divided into two time periods, an early release and a delayed release. The timing of release is particularly important for the prediction of early health effects.

- Detailed Analysis of Radioactive Material Transport for Selected Accident Progression Bins:* Once the basic XSOR algorithm was defined, it was necessary to insert parameters analogous to the quantification of the accident progression event tree in the previous part of the analysis. Since a quantitative uncertainty analysis was one of the objectives of this study, data on the more important parameters were constructed in the form of probability distributions. These distributions were developed based on calculations from the Source Term Code Package (STCP) (Ref. 2.30), CONTAIN (Ref. 2.31), MELCOR (Ref. 2.32), and other calculational and experimental data. The source term parameters determined by an expert panel are shown in Table 2.4. Distributions for parameters that were judged of lesser importance were evaluated by experts drawn from the analysis staff or from other groups at national laboratories. (See Section C.1 of Appendix C for a listing of such parameters for the Surry plant. Similar listings for the other plants may be found in Refs. 2.11 through 2.14.) In rare instances, single-valued estimates were used.
- Grouping of Radioactive Releases:* For these risk analyses, radioactive releases were grouped according to their potential to cause early and latent cancer fatalities and warning time.* Through this "partitioning" process, the large number of radioactive releases calculated with the XSOR codes were collected into a small set of source term groups (30 to 60 in number). This set of groups was then used in the offsite consequence calculations discussed below.

Additional discussion of the methods used to perform the radioactive material transport analysis may be found in Section A.4 of Appendix A. Reference 2.8 provides an extensive discussion of the methods used that is suitable for the reader expert in severe accident and risk analysis.

Section B.4 of Appendix B provides a detailed example calculation showing how the radioactive

*This grouping of source terms by offsite consequence effects is analogous to the grouping of accident sequences into plant damage states by their potential effect on accident progression.

material transport analysis methods summarized above were used in the risk analyses supporting this report.

2.4.2 Products of Radioactive Material Transport Analysis

The product of this part of the risk analysis is the estimate of the radioactive release magnitude, with associated energy content, time, elevation, and duration of release, for each of the specified source term groups developed in the "partitioning" process described above.

The radioactive release estimates generated in this part of the risk analysis can be displayed in a variety of ways. In this report, radioactive release magnitudes are shown in the following ways:

- Distribution of release magnitudes for each of the nine isotopic groups for selected accident progression bins.

The results of the radioactive material transport analysis can vary in form depending on the intended use. For purposes of this report, example results that display the distribution of release magnitudes for selected accident progression bins were obtained. In Part II of this report, the results for two accident progression bins are displayed for each plant. For these selected accident progression bins, the distribution of the radioactive release magnitude (for each of the nine radionuclide groups) is characterized by the mean, median, 5th percentile, and 95th percentile. An example distribution is displayed in Figure 2.6. (Distributions of this type are constructed with the assumption that all estimated source terms are equally likely and thus do not incorporate the frequencies of the individual source terms. Recalculation of these distributions, including consideration of frequencies, does not significantly change the results.)
- Frequency distribution of radioactive releases of iodine, cesium, strontium, and lanthanum.

Chapter 10 displays the absolute frequency* of source term release magnitudes. These results are presented in the form of complementary cumulative distribution functions (CCDFs) of the magnitude of iodine, cesium, strontium, and lanthanum releases.** This

*That is, the combined frequency of all plant damage state frequencies and conditional accident progression bin probabilities.

**These four groups are used to represent the spectrum of possible chemical groups, i.e., from chemically volatile to nonvolatile species.

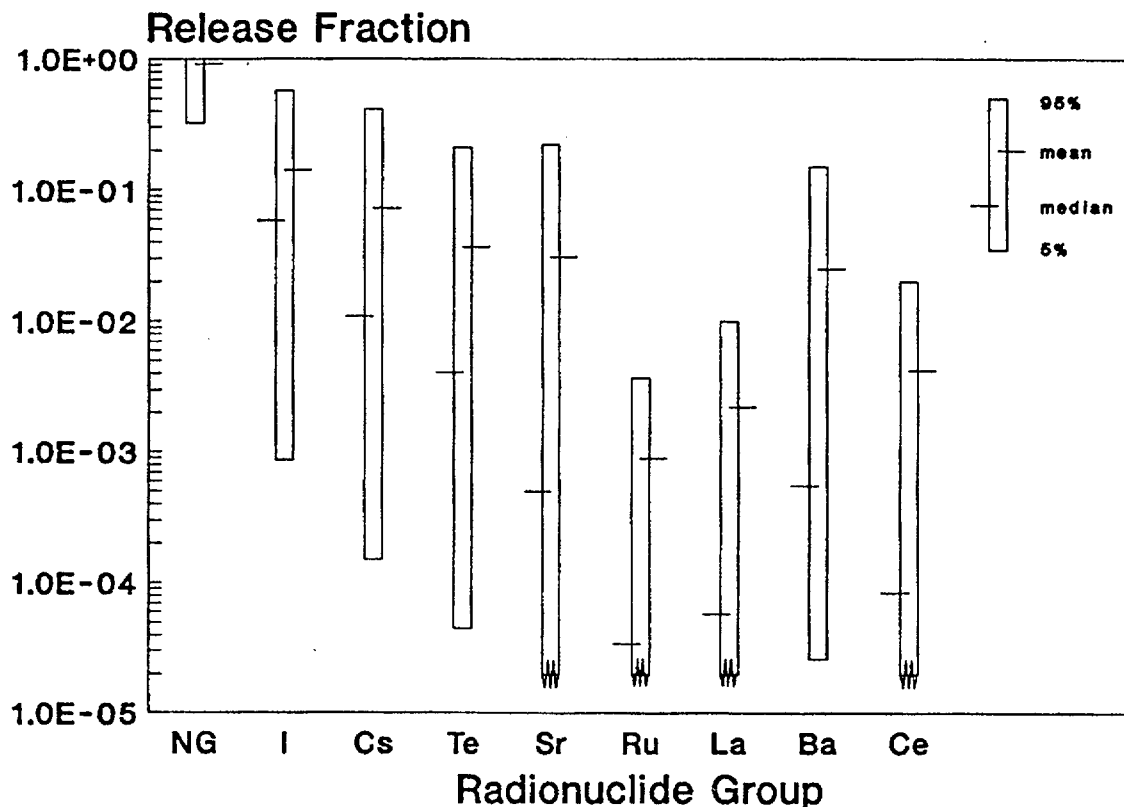

Figure 2.6 Example display of radioactive release distributions.

display provides information on the frequency of source term magnitudes exceeding a specific value for each of the plants. Figure 2.7 displays an example CCDF for one chemical group.

2.5 Offsite Consequence Analysis

2.5.1 Methods

The severe accident radioactive releases described in the preceding section are of concern because of their potential for impacts on the surrounding environment and population. The impacts of such releases to the atmosphere can manifest themselves in a variety of early and delayed health effects, loss of habitability of areas close to the plant site, and economic losses. The fourth part of the risk analysis process shown in Figure 2.1 represents the estimation of these offsite consequences, given the radioactive releases (source term groups) generated in the previous analysis part.

There are five principal steps in the offsite consequence analysis. Briefly, these are:

- Assessment of Pre-accident Inventories of Radioactive Material:* An assessment was made of the pre-accident inventories of each radioactive species in the reactor fuel, using information on the thermal power and refueling cycles for the plants studied. For the source term and offsite consequence analysis, the radioactive species were collected into groups of similar chemical behavior. For these risk analyses, nine groups were used to represent 60 radionuclides considered to be of most importance to offsite consequences: noble gases, iodine, cesium, tellurium, strontium, ruthenium, cerium, barium, and lanthanum.
- Analysis of Transport and Dispersion of Radioactive Material:* The transport and dispersion of radioactive material to offsite

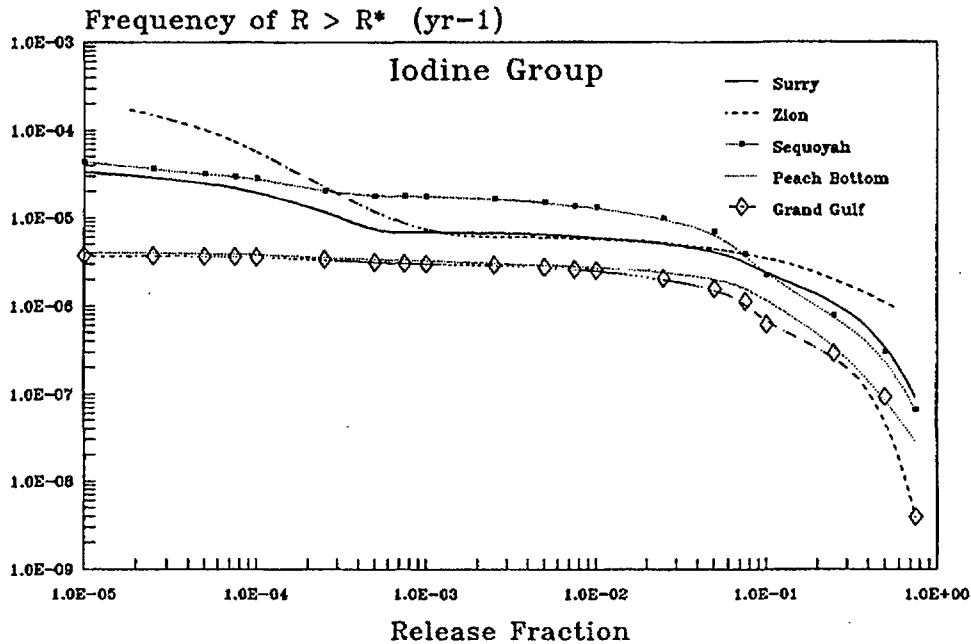

Note: As discussed in Reference 2.29, estimated risks at or below $1E-7$ per reactor year should be viewed with caution because of the potential impact of events not studied in the risk analyses.

Figure 2.7 Example display of source term complementary cumulative distribution function.

areas was modeled in two parts: the initial development of a plume in the wake of plant buildings, using models described in Reference 2.35; and the subsequent downwind transport, which used a straight-line Gaussian plume model, as described in Reference 2.36. The effect of the initial sensible energy content of the plume was included in these models so that under some conditions plume "liftoff" could occur, elevating the contained radioactive material into the atmosphere.

The dispersion models used in this report also explicitly accounted for the variability of transport and deposition with weather conditions.

Meteorological data for each specific power plant site were used. For each of a set of approximately 160 representative weather conditions, a dispersion pattern of the plume was calculated. Deposition of radioactive material

from the plume onto the ground (or water bodies) beneath the plume was based on a set of experimentally derived deposition rates for dry and wet (rain) conditions.

- *Analysis of the Radiation Doses:* Using the dispersion and deposition patterns developed in the previous step and a set of dose conversion factors (which relate a concentration of a radioactive species to a dose to a given body organ) (Refs. 2.37, 2.38, and 2.39), calculations were made of the doses received by the exposed populations via direct (cloudshine, inhalation, groundshine) and indirect (ingestion, resuspension of radioactive material from the ground into the air) pathways. Site-specific population data were used in these calculations. The doses were calculated on a body organ-by-organ basis and combined into health effect estimates in a later step.

2. Summary of Methods

- *Analysis of Dose Mitigation by Emergency Response Actions:* Consideration was given to the mitigating effects of emergency response actions taken immediately after the accident and in the longer term. Effects included were evacuation, sheltering, and relocation of people, interdiction of milk and crops, and decontamination, temporary interdiction, and/or condemnation of land and buildings.

The analysis of offsite consequences for this study included a "base case" and several sets of alternative emergency response actions. For the base case, it was assumed that 99.5 percent of the population within the 10-mile emergency planning zone (EPZ) participated in an evacuation. This set of people was assumed to move away from the plant site at a speed estimated from the plant licensee's emergency plan, after an initial delay (to reach the decision to evacuate and permit communication of the need to evacuate) also estimated from the licensee's plan. It was also assumed that the 0.5 percent of the population that did not participate in the initial evacuation was relocated within 12 to 24 hours after plume passage, based on the measured concentrations of radioactive material in the surrounding area and the comparison of projected doses with proposed Environmental Protection Agency (EPA) guidelines (Ref. 2.40). Similar relocation assumptions were made for the population outside the 10-mile planning zone. Longer-term countermeasures (e.g., crop or land interdiction) were based on EPA and Food and Drug Administration guidelines (Ref. 2.41).

Several alternative emergency response assumptions were also analyzed in this study's offsite consequence and risk analyses. These included:

- Evacuation of 100 percent of the population within the 10-mile emergency planning zone;
- Indoor sheltering of 100 percent of the population within the EPZ (during plume passage) followed by rapid subsequent relocation after plume passage;
- Evacuation of 100 percent of the population in the first 5 miles of the planning zone, and sheltering followed by fast relocation of the population in the second 5 miles of the EPZ; and

- In lieu of evacuation or sheltering, only relocation from the EPZ within 12 to 24 hours after plume passage, using relocation criteria described above.

In each of these alternatives, the region outside the 10-mile zone was subject to a common assumption that relocation was performed based on comparisons of projected doses with EPA guidelines (as discussed above).

- *Calculation of Health Effects:* The offsite consequence analysis calculated the following health effect measures:
 - The number of early fatalities and early injuries expected to occur within 1 year of the accident and the latent cancer fatalities expected to occur over the lifetime of the exposed individuals;
 - The total population dose received by the people living within specific distances (e.g., 50 miles) of the plant; and
 - Other specified measures of offsite health effect consequences (e.g., the number of early fatalities in the population living within 1 mile of the reactor site boundary).

The health effects calculated in this analysis were based on the models of Reference 2.42. This work in turn used the work of the BEIR III report (Ref. 2.43) for its models of latent cancer effects.

The schedule for completing the risk analyses of this report did not permit the performance of uncertainty analyses for parameters of the offsite consequence analysis, although variability due to annual variations in meteorological conditions is included. Such an analysis is, however, planned to be performed.

Section A.5 of Appendix A provides additional discussion of the methods used for performing the offsite consequence analysis. The reader seeking extensive discussion of the methods used is directed to Reference 2.8 and to Reference 2.36, which discusses the computer code used to perform the offsite consequence analysis (i.e., the MELCOR Accident Consequence Code System (MACCS), Version 1.5).

2.5.2 Products of Offsite Consequence Analysis

The product of this part of the risk analysis process is a set of offsite consequence measures for

each source term group. For this report, the specific consequence measures discussed include early fatalities, latent cancer fatalities, total population dose (within 50 miles and entire site region), and two measures for comparison with NRC's safety goals (average individual early fatality probability within 1 mile and average individual latent cancer fatality probability within 10 miles of the site boundary) (Ref. 2.44).

For display in this report, the results of the offsite consequence analyses are combined with the frequencies generated in the previous analysis steps and shown in the form of complementary cumulative distribution functions (CCDFs). This display shows the frequency of consequences occurring at a level greater than a specified amount. Figure 2.8 provides a display of such a CCDF. This information is also provided in tabular form in Chapter 11.

2.6 Uncertainty Analysis

As stated in the introduction to the chapter, an important characteristic of the probabilistic risk analyses conducted in support of this report is that they have explicitly included an estimation of the uncertainties in the calculations of core damage frequency and risk that exist because of incomplete understanding of reactor systems and severe accident phenomena.

There are four steps in the performance of uncertainty analyses. Briefly, these are:

- *Scope of Uncertainty Analyses:* Important sources of uncertainty exist in all four stages of the risk analysis shown in Figure 2.1. In this study, the total number of parameters that could be varied to produce an estimate of the uncertainty in risk was large, and it was somewhat limited by the computer capacity required to execute the uncertainty analyses. Therefore, only the most important sources of uncertainty were included. Some understanding of which uncertainties would be most important to risk was obtained from previous PRAs, discussion with phenomenologists, and limited sensitivity analyses. Subjective probability distributions for parameters for which the uncertainties were estimated to be large and important to risk and for which there were no widely accepted data or analyses were generated by expert panels. Those issues for which expert panels generated probability distributions are listed in Tables 2.2 through 2.4.

- *Definition of Specific Uncertainties:* In order for uncertainties in accident phenomena to be included in the probabilistic risk analyses conducted for this study, they had to be expressed in terms of uncertainties in the parameters that were used in the study. Each section of the risk analysis was conducted at a slightly different level of detail. However, each analysis part (except for offsite consequence analysis, which was not included in the uncertainty analysis) did not calculate the characteristics of the accidents in as much detail as would a mechanistic and detailed computer code. Thus, the uncertain input parameters used in this study are "high level" or summary parameters. The relationships between fundamental physical parameters and the summary parameters of the risk analysis parts are not always clear; this lack of understanding leads to what is referred to in this study as modeling uncertainties. In addition, the values of some important physical or chemical parameters are not known and lead to uncertainties in the summary parameters. These uncertainties were referred to as data uncertainties. Both types of uncertainties were included in the study, and no consistent effort was made to differentiate between the effects of the two types of uncertainties.

Parameters were chosen to be included in the uncertainty analysis if the associated uncertainties were estimated to be large and important to risk.

- *Development of Probability Distributions:* Probability distributions for input parameters were developed by a number of methods. As stated previously, distributions for many key input parameters were determined by panels of experts. The experts used a large variety of techniques to generate probability distributions, including reliance on detailed code calculations, extrapolation of existing experimental and accident data to postulated conditions during the accident, and complex logic networks. Probability distributions were obtained from the expert panels using formalized procedures designed to minimize bias and maximize accuracy and scrutability of the experts' results. These procedures are described in more detail in Section 2.7. Probability distributions for some parameters believed to be of less importance to risk were generated by analysts on the project staff or by phenomenologists from several different

2. Summary of Methods

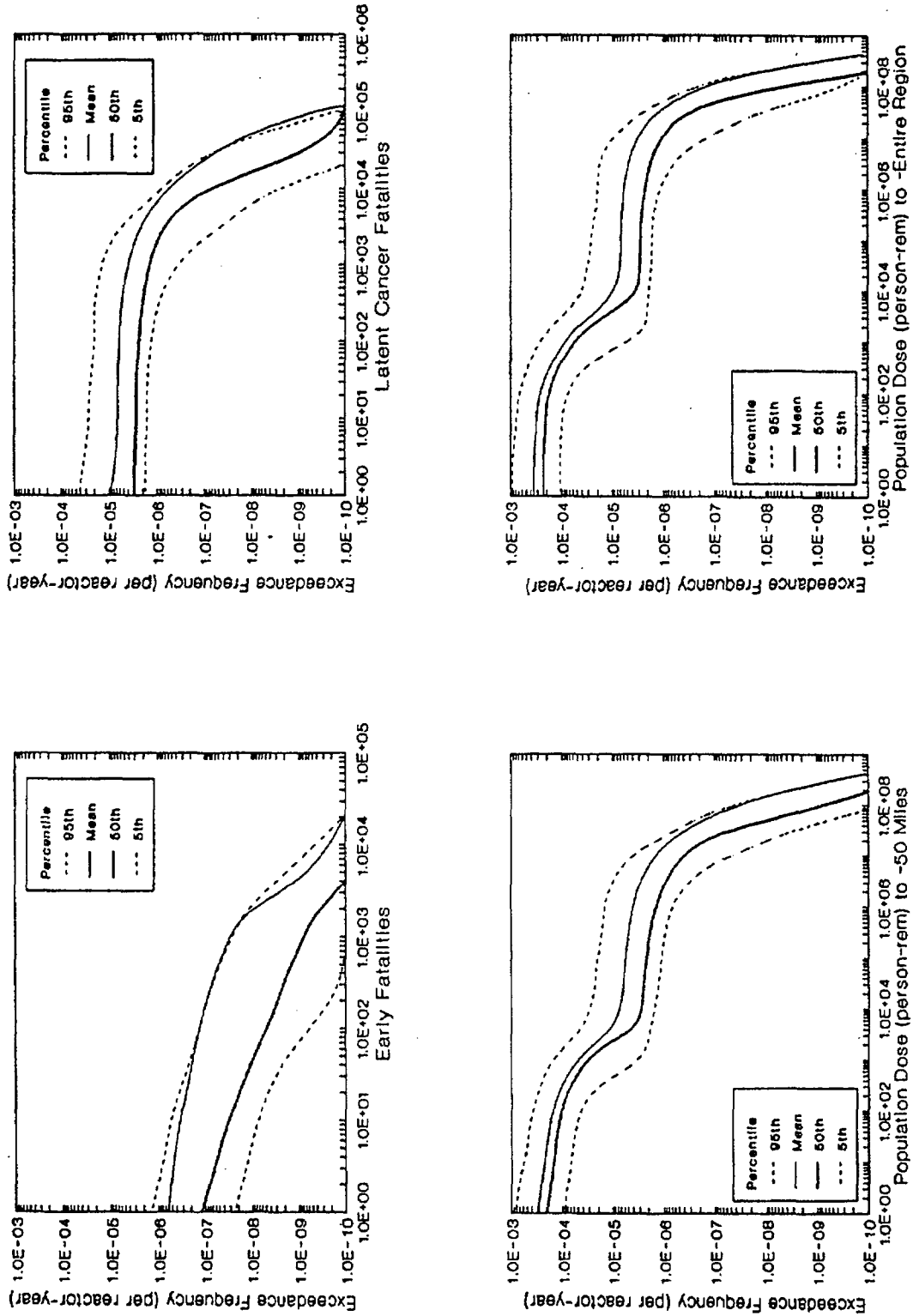

Note: As discussed in Reference 2.29, estimated risks at or below 1E-7 per reactor year should be viewed with caution because of the potential impact of events not studied in the risk analyses.

Figure 2.8 Example display of offsite consequences complementary cumulative distribution function.

national laboratories using techniques like those employed with the expert panels. (Section C.1 of Appendix C provides a listing of parameters to which probability distributions were assigned for the Surry plant. Similar listings for the other plants may be found in Refs. 2.11 through 2.14.)

Probability distributions for many of the most important accident sequence frequency variables were generated using statistical analyses of plant data or data from other published sources.

- *Combination of Uncertainties:* A specialized Monte Carlo method, Latin hypercube sampling, was used to sample the probability distributions defined for the many input parameters. The sample observations were propagated through the constituent analyses to produce probability distributions for core damage frequency and risk. Monte Carlo methods produce results that can be analyzed with a variety of techniques, such as regression analysis. Such methods easily treat distributions with wide ranges and can incorporate correlations between variables. Latin hypercube sampling (Ref. 2.20) provides for a more efficient sampling technique than straightforward Monte Carlo sampling while retaining the benefits of Monte Carlo techniques. It has been shown to be an effective technique when compared to other, more costly, methods (Ref. 2.45). Since many of the probability distributions used in the risk analyses are subjective distributions, the composite probability distributions for core damage frequency and risk must also be considered subjective.

Additional discussion of uncertainty analysis methods is provided in Section A.6 of Appendix A and in detail in Reference 2.8.

2.7 Formal Procedures for Elicitation of Expert Judgment

The risk analysis of severe reactor accidents inherently involves the consideration of parameters for which little or no experiential data exist. Expert judgment was needed to supplement and interpret the available data on these issues. The elicitation of experts on key issues was performed using a formal set of procedures, discussed in greater detail in Reference 2.8. The principal steps of this process are shown in Figure 2.9. Briefly, these steps are:

- *Selection of Issues:* As stated in Section 2.6, the total number of uncertain parameters that could be included in the core damage frequency and risk uncertainty analyses was somewhat limited. The parameters considered were restricted to those with the largest uncertainties, expected to be the most important to risk, and for which widely accepted data were not available. In addition, the number of parameters that could be determined by expert panels was further restricted by time and resource limitations. The parameters that were determined by expert panels are, in the vernacular of this project, referred to as "issues." An initial list of issues was chosen from the important uncertain parameters by the plant analyst, based on results from the first draft NUREG-1150 analyses (Ref. 2.46). The list was further modified by the expert panels. Tables 2.2 through 2.4 list those issues studied by expert panels.
- *Selection of Experts:* Seven panels of experts were assembled to consider the principal issues in the accident frequency analyses (two panels), accident progression and containment loading analyses (three panels), containment structural response analyses (one panel), and source term analyses (one panel). The experts were selected on the basis of their recognized expertise in the issue areas, such as demonstrated by their publications in refereed journals. Representatives from the nuclear industry, the NRC and its contractors, and academia were assigned to panels to ensure a balance of "perspectives." Diversity of perspectives has been viewed by some (e.g., Refs. 2.47 and 2.48) as allowing the problem to be considered from more viewpoints and thus leading to better quality answers. The size of the panels ranged from 3 to 10 experts.
- *Training in Elicitation Methods:* Both the experts and analysis team members received training from specialists in decision analysis. The team members were trained in elicitation methods so that they would be proficient and consistent in their elicitations. The experts' training included an introduction to the elicitation and analysis methods, to the psychological aspects of probability estimation (e.g., the tendency to be overly confident in the estimation of probabilities), and to probability estimation. The purpose of this training was to better enable the experts to transform their knowledge and judgments into the form of probability distributions and to avoid

2. Summary of Methods

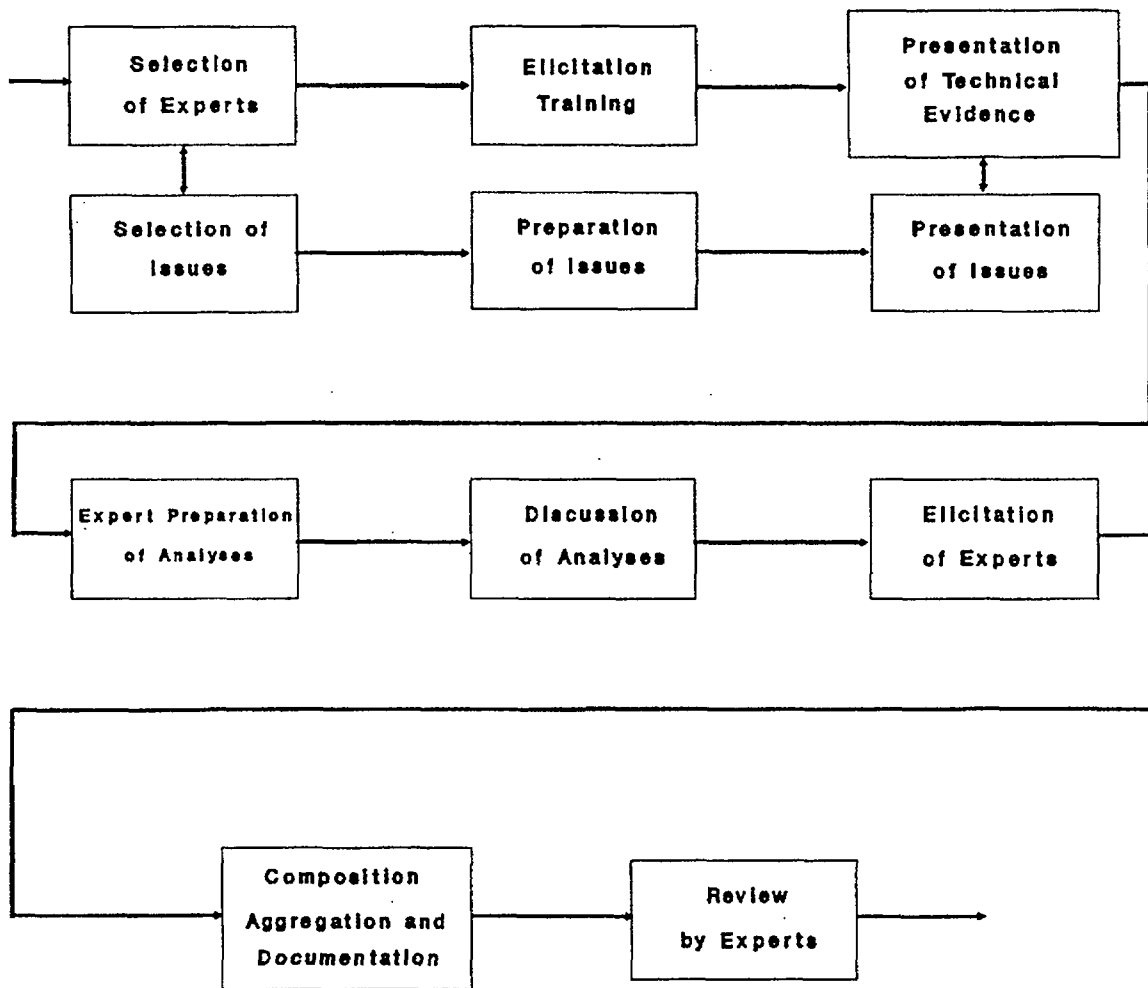

Figure 2.9 Principal steps in expert elicitation process.

particular psychological biases such as overconfidence. Additionally, the experts were given practice in assigning probabilities to sample questions with known answers (almanac questions). Studies such as those discussed in Reference 2.49 have shown that feedback on outcomes can reduce some of the biases affecting judgmental accuracy.

- *Presentation and Review of Issues:* Presentations were made to each panel on the set of issues to be considered, the definition of each issue, and relevant data on each issue. Other parameters considered by the analysis staff to be of somewhat lesser importance were also described to the experts. The purposes of these presentations were to permit the panel to add or drop issues depending on their judgments as to their importance; to provide a specific definition of each issue chosen and the sets of associated boundary conditions imposed by other issue definitions; and to obtain information from additional data sources known to the experts.

In addition, written descriptions of the issues were provided to the experts by the analysis staff. The descriptions provided the same information as provided in the presentations, in addition to reference lists of relevant technical material, relevant plant data, detailed descriptions of the types of accidents of most importance, and the context of the issue within the total analysis. The written descriptions also included suggestions of how the issues could be decomposed into their parts using logic trees. The issues were to be decomposed because the decomposition of problems has been shown to ease the cognitive burden of considering complex problems and to improve the accuracy of judgments (Ref. 2.50).

For the initial meeting, researchers, plant representatives, and interested parties were invited to present their perspectives on the issues to the experts. Frequently, these presentations took several days.

- *Preparation of Expert Analyses:* After the initial meeting at which the issues were presented, the experts were given time to prepare their analyses of the issues. This time ranged from 1 to 4 months. The experts were encouraged to use this time to investigate alternative methods for decomposing the is-

ssues, to search for additional sources of information on the issues, and to conduct calculations. During this period, several panels met to exchange information and ideas concerning the issues. During some of these meetings, expert panels were briefed by the project staff on the results from other expert panels in order to provide the most current data.

- *Expert Review and Discussion:* After the expert panels had prepared their analyses, a final meeting was held in which each expert discussed the methods he/she used to analyze the issue. These discussions frequently led to modifications of the preliminary judgments of individual experts. However, the experts' actual judgments were not discussed in the meeting because group dynamics can cause people to unconsciously alter their judgments in the desire to conform (Ref. 2.51).
- *Elicitation of Experts:* Following the panel discussions, each expert's judgments were elicited. These elicitations were performed privately, typically with an individual expert, an analysis staff member trained in elicitation techniques, and an analysis staff member familiar with the technical subject. With few exceptions, the elicitations were done with one expert at a time so that they could be performed in depth and so that an expert's judgments would not be adversely influenced by other experts. Initial documentation of the expert's judgments and supporting reasoning were obtained in these sessions.
- *Composition and Aggregation of Judgments:* Following the elicitation, the analysis staff composed probability distributions for each expert's judgments. The individual judgments were then aggregated to provide a single composite judgment for each issue. Each expert was weighted equally in the aggregation because this simple method has been found in many studies (e.g., Ref. 2.52) to perform the best.
- *Review by Experts:* Each expert's probability distribution and associated documentation developed by the analysis staff was reviewed by that expert. This review ensured that potential misunderstandings were identified and corrected and that the issue documentation properly reflected the judgments of the expert.

2.8 Risk Integration

2.8.1 Methods

The fifth part of the risk analysis process shown in Figure 2.1 ("Risk Integration") is the integration of the other analysis products into the overall estimate of plant risk. Risk for a given consequence measure is the sum over all postulated accidents of the product of the frequency and consequence of the accident. This part of the analysis consisted of both the combination of the results of the constituent analyses and the subsequent assessment of the relative contributions of different types of accidents (as defined by the plant damage states, accident progression bins, or source term groups) to the total risk.

Appendix A provides a more detailed description of the risk integration process. In order to assist the reader seeking a detailed understanding of this process, an example calculation is provided in Appendix B. This example makes use of actual results for the Surry plant.

2.8.2 Products of Risk Integration

The risk analyses performed in this study can be displayed in a variety of ways. The specific products shown in this summary report are described below, with similar products provided for early fatality risk, latent cancer fatality risk, population dose risk within 50 miles and within the entire area surrounding the site, and for two measures related to NRC's safety goals (Ref. 2.44).

- The total risks from internal and fire events.*

Reflecting the uncertain nature of risk results, such results can be displayed using a probability density function. For Part II of this report (plant-specific results), a histogram is used. This histogram for risk results is like that shown on the right side of Figure 2.2 for the results of the accident frequency analysis. In addition, four measures of the

*For reasons described in Chapter 1, seismic risk is not displayed or discussed in this report.

probability distribution are identified in Figure 2.2 (and throughout this report):

- Mean;
- Median;
- 5th percentile value; and
- 95th percentile value.

A second display of risk results is used in Part III of this report, where results for all five plants are displayed together. This rectangular display (shown on the left side of Fig. 2.2) provides a summary of these four specific measures in a simple graphical form.

- Contributions of plant damage states and accident progression bins to mean risk.

The risk results generated in this report can be decomposed to determine the fractional contribution of individual plant damage states and accident progression bins to the mean risk. An example display of the fractional contribution of plant damage states to mean early and latent cancer fatality risk is provided in Figure 2.10. The estimated values of these relative contributions are somewhat sensitive to the Monte Carlo sampling variation, particularly those contributions that are small. References 2.10 through 2.14 discuss this sensitivity to sampling variation in more detail. These references also include discussion of an alternative method for calculating the relative contributions to mean risk that provides somewhat different results.

- Contributions to risk uncertainty.

Regression analyses were performed to assess the relative contributions of the uncertainty in individual parameters (or groups of parameters) to the uncertainty in risk. Results of these analyses are discussed in Part III of this report and in more detail in References 2.10 through 2.14.

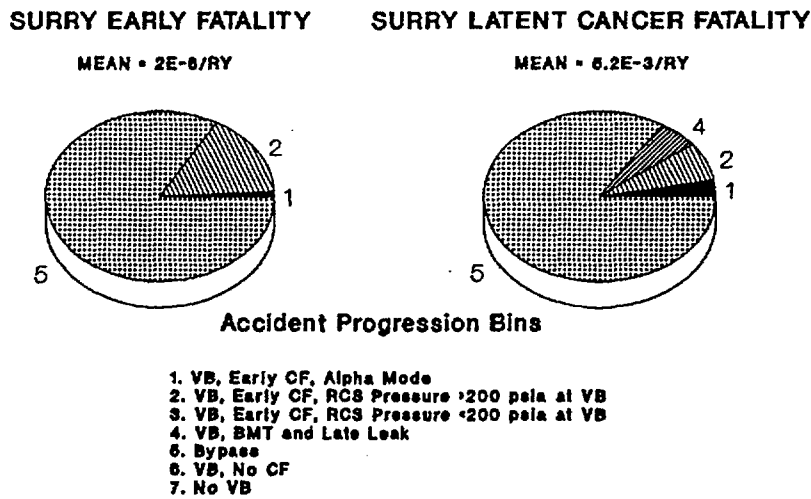
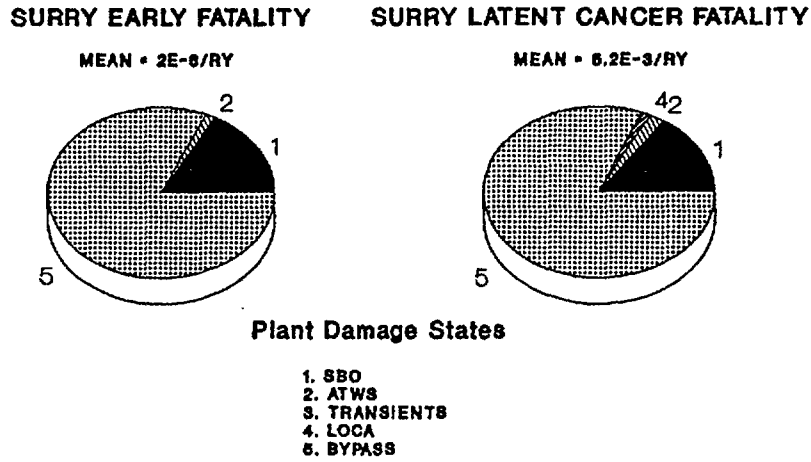

Figure 2.10 Example display of relative contributions to mean risk.

REFERENCES FOR CHAPTER 2

- 2.1 D. M. Ericson, Jr., (Ed.) et al., "Analysis of Core Damage Frequency: Internal Events Methodology," Sandia National Laboratories, NUREG/CR-4550, Vol. 1, Revision 1, SAND86-2084, January 1990.
- 2.2 T. A. Wheeler et al., "Analysis of Core Damage Frequency from Internal Events: Expert Judgment Elicitation," Sandia National Laboratories, NUREG/CR-4550, Vol. 2, SAND86-2084, April 1989.
- 2.3 R. C. Bertucio and J. A. Julius, "Analysis of Core Damage Frequency: Surry Unit 1," Sandia National Laboratories, NUREG/CR-4550, Vol. 3, Revision 1, SAND86-2084, April 1990.
- 2.4 A. M. Kolaczowski et al., "Analysis of Core Damage Frequency: Peach Bottom Unit 2," Sandia National Laboratories, NUREG/CR-4550, Vol. 4, Revision 1, SAND86-2084, August 1989.
- 2.5 R. C. Bertucio and S. R. Brown, "Analysis of Core Damage Frequency: Sequoyah Unit 1," Sandia National Laboratories, NUREG/CR-4550, Vol. 5, Revision 1, SAND86-2084, April 1990.
- 2.6 M. T. Drouin et al., "Analysis of Core Damage Frequency: Grand Gulf Unit 1," Sandia National Laboratories, NUREG/CR-4550, Vol. 6, Revision 1, SAND86-2084, September 1989.
- 2.7 M. B. Sattison and K. W. Hall, "Analysis of Core Damage Frequency: Zion Unit 1," Idaho National Engineering Laboratory, NUREG/CR-4550, Vol. 7, Revision 1, EGG-2554, May 1990.
- 2.8 E. D. Gorham-Bergeron et al., "Evaluation of Severe Accident Risks: Methodology for the Accident Progression, Source Term, Consequence, Risk Integration, and Uncertainty Analyses," Sandia National Laboratories, NUREG/CR-4551, Vol. 1, Draft Revision 1, SAND86-1309, to be published.*
- 2.9 F. T. Harper et al., "Evaluation of Severe Accident Risks: Quantification of Major Input Parameters," Sandia National Laboratories, NUREG/CR-4551, Vol. 2, Revision 1, SAND86-1309, December 1990.
- 2.10 R. J. Breeding et al., "Evaluation of Severe Accident Risks: Surry Unit 1," Sandia National Laboratories, NUREG/CR-4551, Vol. 3, Revision 1, SAND86-1309, October 1990.
- 2.11 A. C. Payne, Jr., et al., "Evaluation of Severe Accident Risks: Peach Bottom Unit 2," Sandia National Laboratories, NUREG/CR-4551, Vol. 4, Draft Revision 1, SAND86-1309, to be published.*
- 2.12 J. J. Gregory et al., "Evaluation of Severe Accident Risks: Sequoyah Unit 1," Sandia National Laboratories, NUREG/CR-4551, Vol. 5, Revision 1, SAND86-1309, December 1990.
- 2.13 T. D. Brown et al., "Evaluation of Severe Accident Risks: Grand Gulf Unit 1," Sandia National Laboratories, NUREG/CR-4551, Vol. 6, Draft Revision 1, SAND86-1309, to be published.*
- 2.14 C. K. Park et al., "Evaluation of Severe Accident Risks: Zion Unit 1," Brookhaven National Laboratory, NUREG/CR-4551, Vol. 7, Draft Revision 1, BNL-NUREG-52029, to be published.*
- 2.15 J. W. Hickman, "PRA Procedures Guide. A Guide to the Performance of Probabilistic Risk Assessments for Nuclear Power Plants," American Nuclear Society and Institute of Electrical and Electronic Engineers, NUREG/CR-2300 (2 of 2), January 1983.
- 2.16 USNRC, "Probabilistic Risk Assessment Reference Document," NUREG-1050, September 1984.
- 2.17 A. Mosleh et al., "Procedures for Treating Common Cause Failures in Safety and Reliability Studies. Procedural Framework and Examples," NUREG/CR-4780, Vol. 1, EPRI NP-5613, January 1988.
- 2.18 A. D. Swain III, "Accident Sequence Evaluation Program—Human Reliability Analysis Procedure," Sandia National

*Available in the NRC Public Document Room, 2120 L Street NW., Washington, DC.

- Laboratories, NUREG/CR-4772, SAND 86-1996, February 1987.
- 2.19 W. J. Luckas, Jr., "A Human Reliability Analysis for the ATWS Accident Sequence with MSIV Closure at the Peach Bottom Atomic Power Station," Brookhaven National Laboratory, May 1986.
- 2.20 M. D. McKay, Jr., "A Comparison of Three Methods for Selecting Values in Input Variables in the Analysis of Output from a Computer Code," *Technometrics* 21(2), 1979.
- 2.21 Commonwealth Edison Company of Chicago, "Zion Probabilistic Safety Study," September 1981.
- 2.22 D. L. Berry et al., "Review and Evaluation of the Zion Probabilistic Safety Study: Plant Analysis," Sandia National Laboratories, NUREG/CR-3300, Vol. 1, SAND83-1118, May 1984.
- 2.23 M. P. Bohn and J. A. Lambright, "Procedures for the External Event Core Damage Frequency Analyses for NUREG-1150," Sandia National Laboratories, NUREG/CR-4840, SAND88-3102, November 1990.
- 2.24 D. L. Bernreuter et al., "Seismic Hazard Characterization of 69 Nuclear Power Sites East of the Rocky Mountains," Lawrence Livermore National Laboratory, NUREG/CR-5250, Vols. 1-8, UCID-21517, January 1989.
- 2.25 Seismicity Owners Group and Electric Power Research Institute, "Seismic Hazard Methodology for the Central and Eastern United States," EPRI NP-4726, July 1986.
- 2.26 J. E. Richardson, USNRC, letter to R. A. Thomas, Seismicity Owners Group, "Safety Evaluation Review of the SOG/EPRI Topical Report Titled 'Seismic Hazard Methodology for the Central and Eastern United States,'" dated September 20, 1988.
- 2.27 G. E. Cummings, "Summary Report on the Seismic Safety Margins Research Program," Lawrence Livermore National Laboratory, NUREG/CR-4431, UCID-20549, January 1986.
- 2.28 M. P. Bohn et al., "Application of the SSMRP Methodology to the Seismic Risk at the Zion Nuclear Power Plant," Lawrence Livermore National Laboratory, NUREG/CR-3428, UCRL-53483, January 1984.
- 2.29 H. J. C. Kouts et al., "Special Committee Review of the Nuclear Regulatory Commission's Severe Accident Risks Report (NUREG-1150)," NUREG-1420, August 1990.
- 2.30 J. A. Gieseke et al., "Source Term Code Package: A User's Guide," Battelle Columbus Division, NUREG/CR-4587, BMI-2138, July 1986.
- 2.31 K. D. Bergeron et al., "User's Manual for CONTAIN 1.0, A Computer Code for Severe Reactor Accident Containment Analysis," Sandia National Laboratories, NUREG/CR-4085, SAND84-1204, July 1985.
- 2.32 R. M. Summers et al., "MELCOR In-Vessel Modeling," *Proceedings of the Fifteenth Water Reactor Safety Information Meeting* (Gaithersburg, MD), NUREG/CP-0091, February 1988.
- 2.33 S. S. Dosanjh, "MELPROG-PWR/MOD1: A Two-Dimensional, Mechanistic Code for Analysis of Reactor Core Melt Progression and Vessel Attack Under Severe Accident Conditions," Sandia National Laboratories, NUREG/CR-5193, SAND88-1824, May 1989.
- 2.34 H. N. Jow et al., "XSOR Codes User's Manual," Sandia National Laboratories, NUREG/CR-5360, SAND89-0943, to be published.*
- 2.35 G. A. Briggs, "Plume Rise Prediction," *Proceedings of Workshop: Lectures on Air Pollution and Environmental Analysis*, American Meteorological Society, 1975.
- 2.36 D. I. Chanin, H. Jow, J. A. Rollstin et al., "MELCOR Accident Consequence Code System (MACCS)," Sandia National Laboratories, NUREG/CR-4691, Vols. 1-3, SAND86-1562, February 1990.
- 2.37 D. C. Kocher, "Dose Rate Conversion Factors for External Exposure to Photons

*Available in the NRC Public Document Room, 2120 L Street NW., Washington, DC.

2. Summary of Methods

- and Electrons," Oak Ridge National Laboratory, NUREG/CR-1918, ORNL/NUREG-79, August 1981.
- 2.38 International Commission on Radiological Protection, "Recommendations of ICRP," Publication 26, *Annals of ICRP*, Vol. 1, No. 3, 1977.
- 2.39 International Commission on Radiological Protection, "Limits for Intakes of Radionuclides by Workers," Publication 30, *Annals of ICRP*, Vol. 2, Nos. 3 and 4, 1978.
- 2.40 U. S. Environmental Protection Agency, "Manual of Protective Action Guides and Protective Actions for Nuclear Incidents," Office of Radiation Programs, Draft, 1989.
- 2.41 U.S. Department of Health and Human Services/Food and Drug Administration, "Accidental Radioactive Contamination of Human Food and Animal Feeds; Recommendations for State and Local Agencies," *Federal Register*, Vol. 47, No. 205, pp. 47073-47083, October 22, 1982.
- 2.42 J. S. Evans et al., "Health Effects Model for Nuclear Power Plant Accident Consequence Analysis," Harvard University, NUREG/CR-4214, SAND85-7185, August 1985.
- 2.43 U.S. National Research Council, National Academy of Sciences, Committee on the Biological Effects of Ionizing Radiation, "The Effects on Populations of Exposure to Low Levels of Ionizing Radiation: 1980," National Academy Press, 1980.
- 2.44 USNRC, "Safety Goals for the Operation of Nuclear Power Plants; Policy Statement," *Federal Register*, Vol. 51, p. 30028, August 21, 1986.
- 2.45 R. L. Iman and J. C. Helton, "A Comparison of Uncertainty and Sensitivity Analysis Techniques for Computer Models," Sandia National Laboratories, NUREG/CR-3904, SAND84-1461, May 1985.
- 2.46 USNRC, "Reactor Risk Reference Document," NUREG-1150, Vols. 1-3, Draft for Comment, February 1987.
- 2.47 P. A. Seaver, "Assessments of Group Preferences and Group Uncertainty for Decision Making," University of Southern California, Social Sciences Research Institute, 1976.
- 2.48 J. M. Booker and M. A. Meyer, "Sources and Effects of Interexpert Correlation: An Empirical Study," *IEEE Transactions on Systems, Man, and Cybernetics*, Vol. 18, No. 1, pp. 135-142, 1988.
- 2.49 S. Lichtenstein et al., "Calibration of Probabilities: The State of the Art to 1980," in *Judgment Under Uncertainty: Heuristics and Biases*, Cambridge University Press, 1982.
- 2.50 J. S. Armstrong et al., "Use of the Decomposition Principle in Making Judgments," *Organizational Behavior and Human Performance*, 14: 257-263, 1975.
- 2.51 I. C. Janis, *Victims of Group Think: A Psychological Study of Foreign Policy Decisions and Fiascoes*, Houghton Mifflin, Boston, MA.
- 2.52 H. F. Martz et al., "Eliciting and Aggregating Subjective Judgments—Some Experimental Results," *Proceedings of the 1984 Statistical Symposium on National Energy Issues* (Seattle, WA), NUREG/CP-0063, July 1985.

PART II

Summary of Plant Results

3. SURRY PLANT RESULTS

3.1 Summary Design Information

The Surry Power Station is a two-unit site. Each unit, designed by the Westinghouse Corporation, is a three-loop pressurized water reactor (PWR) rated at 2441 MWt (788 MWe) and is housed in a subatmospheric containment designed by Stone and Webster Engineering Corporation. The balance of plant systems were engineered and built by Stone and Webster Engineering Corporation. Located on the James River near Williamsburg, Virginia, Surry 1 started commercial operation in 1972. Some important system design features of the Surry plant are described in Table 3.1. A general plant schematic is provided in Figure 3.1.

This chapter provides a summary of the results obtained in the detailed risk analyses underlying this report (Refs. 3.1 and 3.2). A discussion of perspectives with respect to these results is provided in Chapters 8 through 12.

3.2 Core Damage Frequency Estimates

3.2.1 Summary of Core Damage Frequency Estimates

The core damage frequency and risk analyses performed for this study considered accidents initiated by both internal and external events (Ref. 3.1). The core damage frequency results obtained from internal events are provided in graphical form, displayed as a histogram, in Figure 3.2 (Section 2.2.2 discusses histogram development). The core damage frequency results obtained from both internal and external events are provided in tabular form in Table 3.2.

The Surry plant was previously analyzed in the Reactor Safety Study (RSS) (Ref. 3.3). The RSS calculated a point estimate core damage frequency from internal events of $4.6E-5$ per year. The present study calculated a total median core damage frequency from internal events of $2.3E-5$ per year. For a detailed discussion of, and insights into, the comparison between this study and the RSS, see Chapter 8.

3.2.1.1 Internally Initiated Accident Sequences

A detailed description of accident sequences important at the Surry plant is provided in Reference 3.1. For this summary report, the accident se-

quences described in that report have been grouped into five summary plant damage states. These are:

- Station blackout,
- Large and small loss-of-coolant accidents (LOCAs),
- Anticipated transients without scram (ATWS),
- All other transients except station blackout and ATWS, and
- Interfacing-system LOCA and steam generator tube rupture.

The relative contributions of these groups to the mean internal-event core damage frequency at Surry are shown in Figure 3.3. From Figure 3.3, it is seen that station blackout sequences are the largest contributors to mean core damage frequency. It should be noted that the plant configuration was modeled as of March 1988 and thus does not reflect implementation of the station blackout rule.

Within the general class of station blackout accidents, the more probable combinations of failures leading to core damage are:

- Loss of onsite and offsite ac power and failure of the auxiliary feedwater (AFW) system. All core heat removal is unavailable after failure of AFW. Station blackout results in the unavailability of the high-pressure injection system, the containment spray system, and the inside and outside containment spray recirculation systems. For station blackout at Unit 1 alone, it was assessed that one high-pressure injection (HPI) pump at Unit 2 would not be sufficient to provide feed and bleed cooling through the crossconnect while at the same time provide charging flow to Unit 2. Core damage was estimated to begin in approximately 1 hour if AFW and HPI flow had not been restored by that time.
- Loss of onsite and offsite ac power results in the unavailability of the high-pressure injection system, the containment spray system, the inside and outside containment spray recirculation systems, and the motor-driven auxiliary feedwater pumps. While the loss of all ac power does not affect instrumentation at the start of the station blackout, a long

3. Surry Plant Results

Table 3.1 Summary of design features: Surry Unit 1.

| | |
|---|---|
| 1. Coolant Injection Systems | <ul style="list-style-type: none">a. High-pressure safety injection and recirculation system with 2 trains and 3 pumps.b. Low-pressure injection and recirculation system with 2 trains and 2 pumps.c. Charging system provides normal makeup flow with safety injection crosstie to Unit 2. |
| 2. Steam Generator Heat Removal Systems | <ul style="list-style-type: none">a. Power conversion system.b. Auxiliary feedwater system (AFWS) with 3 trains and 3 pumps (2 MDPs, 1 TDP)* and crosstie to Unit 2 AFWS. |
| 3. Reactivity Control Systems | <ul style="list-style-type: none">a. Control rods.b. Chemical and volume control systems. |
| 4. Key Support Systems | <ul style="list-style-type: none">a. dc power provided by 2-hour design basis station batteries.b. Emergency ac power provided by 1 dedicated and 1 swing diesel generator (both self-cooled).c. Component cooling water provides cooling to RCP thermal barriers.d. Service water is gravity-fed system that provides heat removal from containment following an accident. |
| 5. Containment Structure | <ul style="list-style-type: none">a. Subatmospheric (10 psia).b. 1.8 million cubic feet.c. 45 psig design pressure.d. Reinforced concrete. |
| 6. Containment Systems | <ul style="list-style-type: none">a. Spray injection initiated at 25 psia with 2 trains and 2 pumps.b. Inside spray recirculation initiated (with 2-minute time delay) at 25 psia with 2 trains and 2 pumps (both pumps inside containment).c. Outside spray recirculation initiated (with 5-minute time delay) at 25 psia with 2 trains and 2 pumps (both pumps outside containment).d. Inside and outside spray recirculation systems are the only sources of containment heat removal after a LOCA. |

*MDP — Motor-Driven Pump.
TDP — Turbine-Driven Pump.

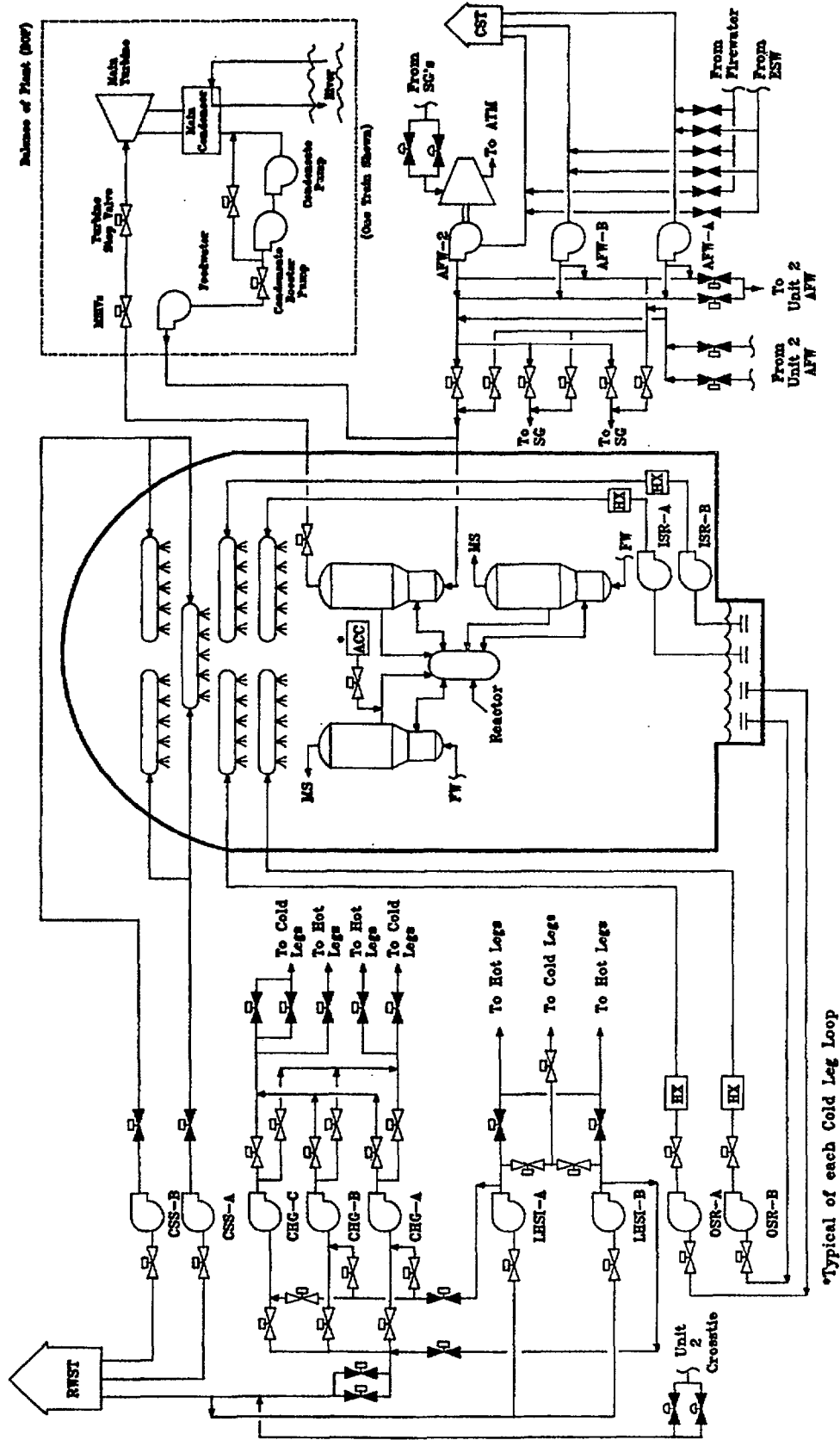

Figure 3.1 Surry plant schematic.

3. Surry Plant Results

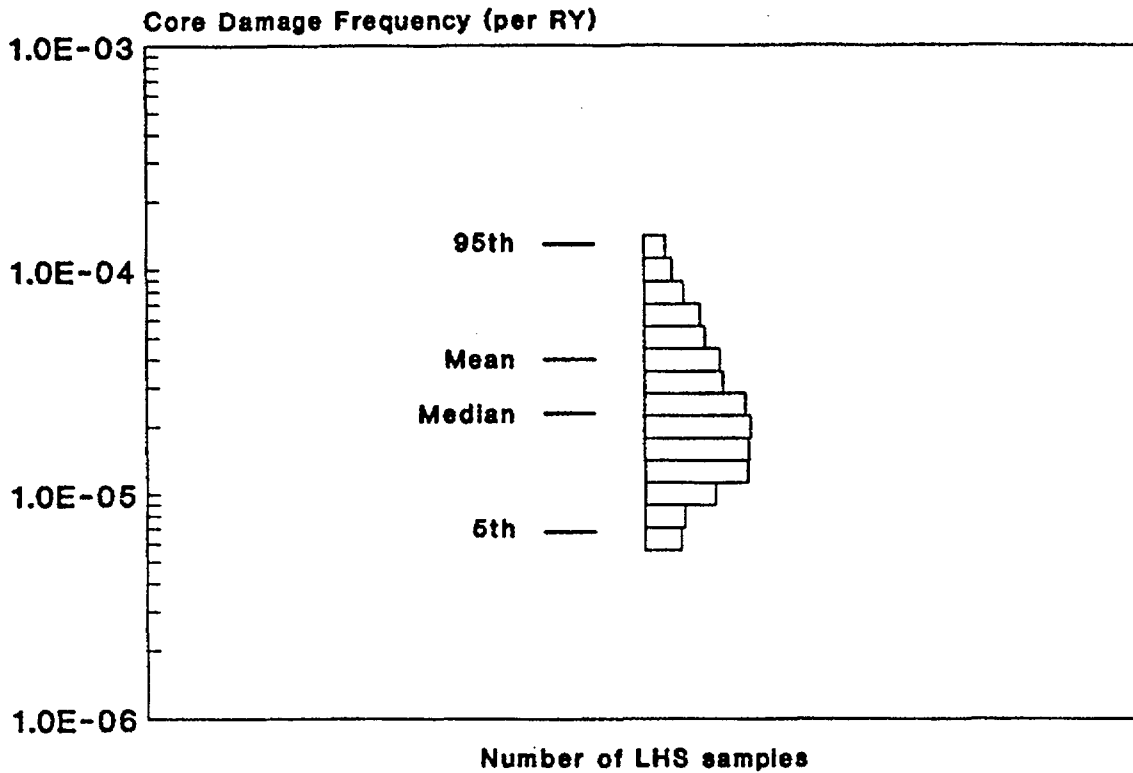

Figure 3.2 Internal core damage frequency results at Surry.*

Table 3.2 Summary of core damage frequency results: Surry.*

| | 5% | Median | Mean | 95% |
|-------------------|---------|--------|--------|--------|
| Internal Events | 6.8E-6 | 2.3E-5 | 4.0E-5 | 1.3E-4 |
| Station Blackout | | | | |
| Short Term | 1.1E-7 | 1.7E-6 | 5.4E-6 | 2.3E-5 |
| Long Term | 6.1E-7 | 8.2E-6 | 2.2E-5 | 9.5E-5 |
| ATWS | 3.2E-8 | 4.2E-7 | 1.6E-6 | 5.9E-6 |
| Transient | 7.2E-8 | 6.9E-7 | 2.0E-6 | 6.0E-6 |
| LOCA | 1.2E-6 | 3.8E-6 | 6.0E-6 | 1.6E-5 |
| Interfacing LOCA | 3.8E-11 | 4.9E-8 | 1.6E-6 | 5.3E-6 |
| SGTR | 1.2E-7 | 7.4E-7 | 1.8E-6 | 6.0E-6 |
| External Events** | | | | |
| Seismic (LLNL) | 3.9E-7 | 1.5E-5 | 1.2E-4 | 4.4E-4 |
| Seismic (EPRI) | 3.0E-7 | 6.1E-6 | 2.5E-5 | 1.0E-4 |
| Fire | 5.4E-7 | 8.3E-6 | 1.1E-5 | 3.8E-5 |

*As discussed in Reference 3.4, core damage frequencies below 1E-5 per reactor year should be viewed with caution because of the remaining uncertainties in PRA (e.g., events not considered).

**See "Externally Initiated Accident Sequences" in Section 3.2.1.2 for discussion.

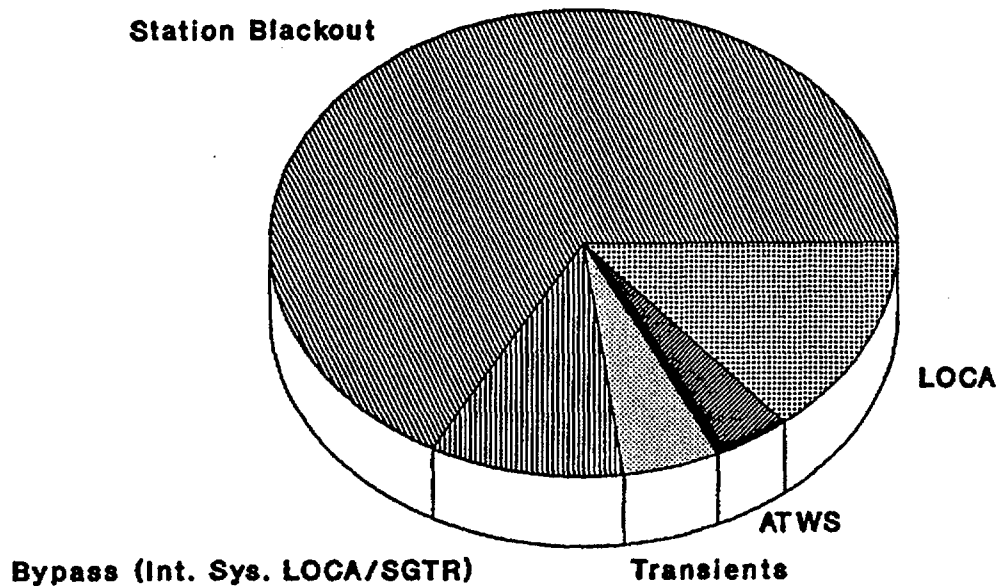

Total Mean Core Damage Frequency: $4.0E-5$

Figure 3.3 Contributors to mean core damage frequency from internal events at Surry.

duration station blackout leads to battery depletion and subsequent loss of vital instrumentation. Battery depletion was concluded to occur after approximately 4 hours. The ability to subsequently provide decay heat removal with the turbine-driven AFW pump is lost because of the loss of all instrumentation and control power. Using information from Reference 3.5, approximately 3 hours beyond the time of battery depletion was allowed for restoration of ac power before core uncover would occur.

- Loss of onsite and offsite ac power, followed by a reactor coolant pump seal LOCA due to loss of all seal cooling. Station blackout also results in the unavailability of the HPI system, as well as the auxiliary feedwater motor-driven pumps, the containment spray system, and the inside and outside spray recirculation systems. Continued coolant loss through the failed seals, with unavailability of the HPI system, leads to core uncover.

Within the general class of LOCAs, the more probable combinations of failures are:

- LOCA with an equivalent diameter of greater than 6 inches in the reactor coolant system (RCS) piping with failure of the low-pressure injection or recirculation system. Recovery of equipment is unlikely for the system failures assessed to be most likely and, because the break size is sufficiently large, the time to core uncover is approximately 5 to 10 minutes, leaving virtually no time for recovery actions. All containment heat removal systems are available. The dominant contributors to failure of the low-pressure recirculation function are the common-cause failure of the refueling water storage tank (RWST) isolation valves to close, common-cause failure of the pump suction valves to open, common-cause failure of the discharge isolation valves to the hot legs to open, or miscalibration of the RWST level sensors.
- Intermediate-size LOCAs with an equivalent diameter of between 2 and 6 inches in the

3. Surry Plant Results

RCS piping with failure of the low-pressure injection or recirculation core cooling system. All containment heat removal systems are available, but the continued heatup and boiloff of primary coolant leads to core uncover in 20 to 50 minutes. The dominant contributors to low-pressure injection failure are common-cause failure of the low-pressure injection (LPI) pumps to start or plugging of the normally open LPI injection valves.

- Small-size LOCAs with an equivalent diameter of between 1/2 and 2 inches in the RCS piping with failure of the HPI system. All containment heat removal systems are available, but the continued heatup and boiloff of primary coolant leads to core uncover in 1 to 8 hours. The dominant contributors to HPI system failures are hardware failures of the check valves in the common suction and discharge line of all three charging pumps or common-cause failure of the motor-operated valves in the HPI discharge line.

Within the general class of containment bypass accidents, the more probable combinations of failures are:

- An interfacing-system LOCA resulting from a failure of any one of the three pairs of check valves in series that are used to isolate the high-pressure RCS from the LPI system. The failure modes of interest for Event V are rupture of valve internals on both valves or failure of one valve to close upon repressurization (e.g., during a return to power from cold shutdown) combined with rupture of the other valve. The resultant flow into the low-pressure system is assumed to result in failure (rupture) of the low-pressure piping or components outside the containment boundary. Although core inventory makeup by the high-pressure systems is initially available, inability to switch to recirculation would eventually lead to core damage approximately 1 hour after the initial failure. Because of the location of the postulated system failure (outside containment), all containment mitigating systems are bypassed.
- A steam generator tube rupture (SGTR) accident initiated by the double-ended guillotine rupture of one steam generator (SG) tube. (Multiple tube ruptures may be possible but were not considered in this analysis.) If the operators fail to depressurize the reactor

coolant system in a timely manner (in about 45 minutes), there is a high probability that water will be forced through the safety relief valves (SRVs) on the steam line from the affected SG. The probability that the SRVs will fail to reclose under these conditions is also estimated to be very high (near 1.0). Failure to close (gag the SRVs) by a local, manual action results in a non-isolable path from the RCS to the environment. After the entire contents of the refueling water storage tank are pumped through the broken SG tube, the core uncovers. The onset of core degradation is thus not expected until about 10 hours after the start of the accident.

3.2.1.2 Externally Initiated Accident Sequences

A detailed description of accident sequences initiated by external events important at the Surry plant is provided in Part 3 of Reference 3.1. The accident sequences described in that reference have been divided into two main types for this study. These are:

- Seismic, and
- Fire.

A scoping study has also been performed to assess the potential effects of other externally initiated accidents (Ref. 3.1, Part 3). This analysis indicated that the following external-event sources could be excluded based on the low frequency of the initiating event:

- Air crashes,
- Hurricanes,
- Tornados,
- Internal flooding, and
- External flooding.

1. Seismic Accident Frequency Analysis

The relative contribution of classes of seismically and fire-initiated accidents to the total mean frequency of externally initiated core damage accidents is provided in Figure 3.4. As may be seen, seismically initiated loss of offsite power plant transients and transients that (through cooling system failures) lead to reactor coolant pump seal LOCAs are the most likely causes of externally caused core damage accidents. For these two accident initiators, the more probable combinations of system failures are:

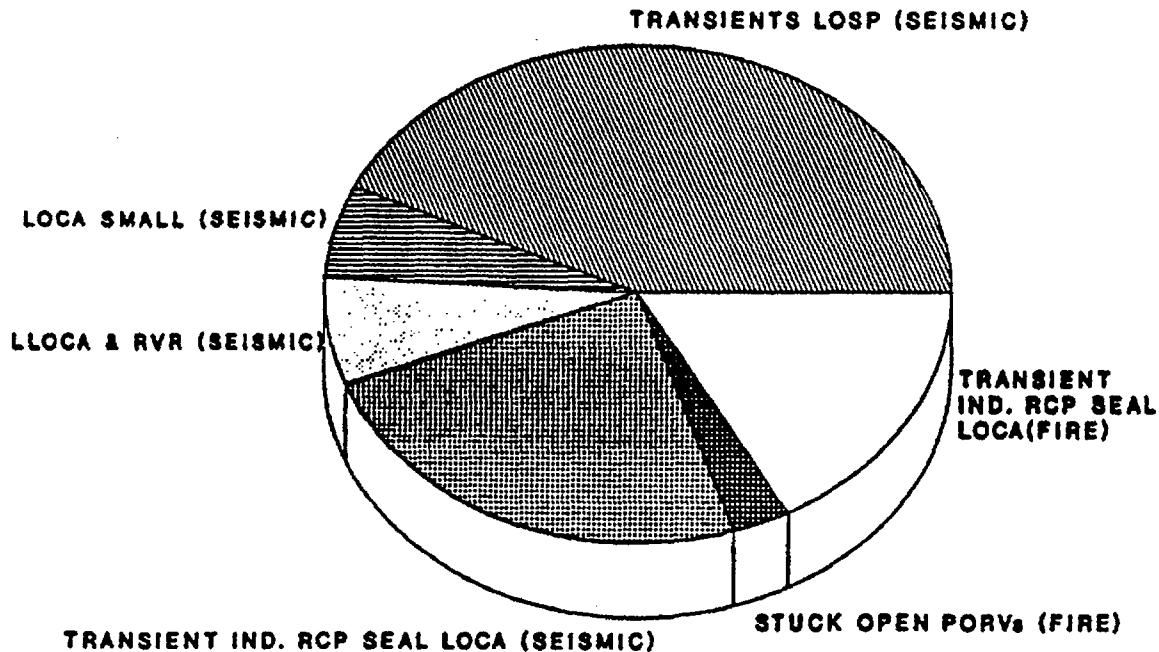

Figure 3.4 Contributors to mean core damage frequency from external events (LLNL hazard curve) at Surry.

- Transient-initiated accident sequences resulting from loss of offsite power in conjunction with failures of the auxiliary feedwater system and failure of the feed and bleed mode of core cooling. These result from either seismically induced diesel generator failures (causing station blackout and eventual battery depletion) or from seismically induced failure of the condensate storage tank in conjunction with power-operated relief valve (PORV) failures.
- Loss of offsite power (LOSP) due to seismically induced failure of ceramic insulators in the switchyard, with simultaneous (seismic) failure of both high-pressure injection (HPI) and component cooling water (CCW) systems (the redundant sources of seal cooling). Failures of HPI result from seismic failures of the refueling water storage tank or emergency diesel generator load panels, while seismic failures of the diesels or the CCW

heat exchanger supports result in loss of the CCW system.

As discussed in Chapter 2, the seismic analysis in this report made use of two sets of hazard curves from Lawrence Livermore National Laboratory (LLNL) (Ref. 3.6) and the Electric Power Research Institute (EPRI) (Ref. 3.7). The above accident sequences are dominant for both sets of hazard curves. In addition, the differences between the seismic risk estimates shown in Table 3.2 for the LLNL and the EPRI cases are due entirely to the differences between the two sets of hazard curves. That is, the system models, failure rates, and success logic were identical for both estimates.

The seismic hazard associated with the curves developed by EPRI was significantly less than that of the LLNL curves. Differences between these curves result primarily from differences between the methodology and assumptions used to develop the hazard curves. In the LLNL program, considerable emphasis was placed on a wide range

3. Surry Plant Results

of uncertainty in the ground-motion attenuation models, while a relatively coarse set of seismic tectonic provinces was used in characterizing each site. By contrast, in the EPRI program considerable emphasis was placed on a fine zonation for the tectonic provinces, and very little uncertainty in the ground-motion attenuation was considered. In any case, it is the difference between the two sets of hazard curves that causes the differences between the numeric estimates in Table 3.2.

2. Fire Accident Frequency Analysis

The fire-initiated accident frequency analyses performed for this report considered the impact of fires beginning in a variety of separate locations within the plant. Those locations found to be most important were:

- Emergency switchgear room,
- Control room,
- Auxiliary building, and
- Cable vault and tunnel.

In the emergency switchgear room, a fire is assumed to fail either control or power cables for both HPI and CCW, leading directly to a reactor coolant pump seal LOCA. No additional random failures were required for this sequence to lead to core damage. (Credit was given for operator recovery by crossconnecting the Unit 2 HPI system.) The identical scenario arises as the result of fires postulated in the auxiliary building and the cable vault and tunnel. Thus, fires in these three areas both cause the initiating event (a seal LOCA) and fail the system required to mitigate the scenario (i.e., HPI).

In the control room, a fire in a bench board was determined to lead to spurious actuation of a PORV with smoke-induced abandonment of the control room. A low probability of successful operator recovery actions from the remote shutdown panel (RSP) was assessed since the PORV closure status is not displayed at the RSP. In addition, the PORV block valve controls in the RSP are not routed independently of the control room bench board and thus may not function.

The frequency of fire-initiated accident scenarios in other locations contributed less than 10 percent to the total fire-initiated core damage frequency.

3.2.2 Important Plant Characteristics (Core Damage Frequency)

Characteristics of the Surry plant design and operation that have been found to be important in the analysis of core damage frequency include:

1. Crossties Between Units

The Surry plant has numerous crossties between similar systems at Units 1 and 2. Some of these were installed in order to comply with requirements of 10 CFR Part 50, Appendix R (fire protection) (Ref. 3.8) or high-energy line-break threats, and some were installed for operational reasons. Crossties exist for the auxiliary feedwater system, the charging pump system, the charging pump cooling system, and the refueling water storage tanks. These crossties are subject to technical specifications, their potential use is included in the plant operating procedures, and they are reviewed in operator training. The availability of such crossties was estimated to reduce the internal-event core damage frequency by approximately a factor of 3.

2. Diesel Generators

Surry is a two-unit site with three emergency diesel generators (DGs), one of which is a swing diesel (which can be aligned to one unit or the other), while many other PWR plants have dedicated diesels for each safety-grade power train (i.e., four DGs for a two-unit site). Each DG is self-cooled and supplied with a dedicated battery (independent of the batteries providing power to the vital dc buses) for starting. The latter two factors eliminate potential common-cause failure modes found important at other plants in this study (e.g., Peach Bottom and Grand Gulf). The Surry site also has a gas turbine generator. However, administrative procedures and design characteristics of support equipment (e.g., dc batteries and compressed air) preclude its use during a station blackout accident.

3. Reactor Coolant Pump Seals

At Surry, there are two diverse and independent methods for providing reactor coolant pump seal cooling: the component cooling water system and the charging system (which has its own dedicated cooling system). The only common support systems for seal cooling are ac and dc power. As such, reactor coolant pump seal LOCAs have been

found important only in station blackout sequences. This is in contrast to some other PWR plants that have a dependency between charging pumps and the component cooling water system and thus greater potential for loss of seal cooling. Without cooling, the seals were expected to degrade or fail. The probability of seal failure upon loss of seal cooling was studied in detail by the expert panel elicitation (Ref. 3.9). Reflecting this, the Surry analyses have found that station blackout accident sequences with significant seal leakage are important contributors to the total frequency of core damage.

4. Battery Capacity

For the Surry plant, the station Class 1E battery depletion time following station blackout has been estimated to be 4 hours (Ref. 3.5). The inability to ensure availability for longer times contributes significantly to the frequency of core damage resulting from station blackout accident sequences. The batteries are designed and tested for 2 hours. A 4-hour battery depletion time is considered realistic because of the margin in the design and possible load shedding.

5. Capability for Feed and Bleed Core Cooling

In the Surry plant, the high-pressure injection system and the power-operated relief valves have the capability to provide feed and bleed core cooling in the event of loss of the cooling function of the steam generators. This capability to provide core cooling through feed and bleed is estimated to result in approximately a factor of 1.4 reduction in core damage frequency. Without the crossties of auxiliary feedwater to Unit 2, which enhances overall reliability of the auxiliary feedwater system, the benefit of feed and bleed cooling would be much greater.

3.2.3 Important Operator Actions

The estimation of accident sequence and total core damage frequencies depends substantially on the credit given to operating crews in performing actions before and during an accident. Failure to perform these actions correctly and reliably will have a substantial impact on estimated core damage frequency. For the Surry plant, actions found to be important are discussed below.

During loss of offsite power and station blackout, important actions required to be taken by the operating crew to prevent core damage include:

- Align alternative source of condensate to condensate storage tank

The primary source of condensate for the AFW system is a 100,000-gallon tank. This is nominally sufficient for the duration of most station blackout events. But in the event that a steam generator becomes faulted, the increased AFW flow would require the provision of additional condensate water. This would involve manual local actions.

- Isolate condenser water box

Surry has a somewhat unique gravity-fed service water system that relies on the head difference between the intake canal and the discharge canal to provide flow through service water heat exchangers. The intake canal is normally supplied with water by the circulating water pumps. These pumps are not provided with emergency power and are thus unavailable after a loss of offsite power. The condenser at each unit is provided with four inlet and four outlet isolation valves. These isolation valves are provided with emergency power. Each inlet isolation valve is provided with a hand wheel, located in the turbine building, in order to allow manual condenser isolation during station blackout to avoid draining the canal.

- Cool down and depressurize the RCS

The Emergency Contingency Actions (ECAs) call for depressurization of the secondary side of the steam generators during a station blackout to provide cooldown and depressurization of the reactor coolant system. This action is done through manual, local valve lineups.

During steam generator tube rupture, the most important operator action is to cool down and depressurize the RCS within approximately 45 minutes after the event in order to prevent lifting the relief valves on the damaged steam generator. Other possible recovery actions considered in this accident sequence include: provision of an alternative source of steam generator feed flow in response to a loss of feed flow; crossconnect of HPI from Unit 2 or opening of alternative injection paths in response to failure of safety injection flow; and isolation of a damaged, faulted steam generator.

3. Surry Plant Results

During small-break and medium-break LOCA accident sequences, two human actions are principally important in response to loss of core coolant injection or recirculation. These are:

- Cool down and depressurize the RCS

RCS cooldown and depressurization is the procedure directed for all small-break LOCAs. This event is important to reduce the pressure in the RCS and thus reduce the leak rate. Successful cooldown and depressurization of the RCS will delay the need to go to recirculation cooling.

- Crossconnect high-pressure injection (HPI)

In the event that HPI pumps or water sources are unavailable at Unit 1, HPI flow can be provided via a crosstie with the Unit 2 charging system. This crosstie requires an operator to locally open and/or close valves in the charging pump area. It was estimated that the crossconnect of HPI would require 15 to 20 minutes. This and other timing considerations were such that the HPI crossconnect was considered viable only for small and very small LOCAs.

3.2.4 Important Individual Events and Uncertainties (Core Damage Frequency)

As discussed in Chapter 2, the process of developing a probabilistic model of a nuclear power plant involves the combination of many individual events (initiators, hardware failures, operator errors, etc.) into accident sequences and eventually into an estimate of the total frequency of core damage. After development, such a model can also be used to assess the relative importance and contribution of the individual events. The detailed studies underlying this report have been analyzed using several event importance measures. The results of the analyses using two measures, "risk reduction" and "uncertainty" importance, are summarized below.

- Risk (core damage frequency) reduction importance measure (internal events)

The risk-reduction importance measure is used to assess the change in core damage frequency as a result of setting the probability of an individual event to zero. Using this measure, the following individual events were found to cause the greatest reduction in the

estimated core damage frequency if their probabilities were set to zero:

- Loss of offsite power initiating event. The core damage frequency would be reduced by approximately 61 percent.
- Failure of diesel generator number one to start. The core damage frequency would be reduced by approximately 25 percent.
- Probability of not recovering ac electric power between 3 and 7 hours after loss of offsite power. The core damage frequency would be reduced by approximately 24 percent.
- Failure to recover diesel generators. The core damage frequency would be reduced by approximately 18 to 21 percent.
- Uncertainty importance measure (internal events)

A second importance measure used to evaluate the core damage frequency results is the uncertainty importance measure. For this measure, the relative contribution of the uncertainty of groups of component failures and basic events to the uncertainty in total core damage frequency is calculated. Using this measure, the following event groups were found to be most important:

- Probabilities of diesel generators failing to start when required;
- Probabilities of diesel generators failing to run for 6 hours;
- Frequency of loss of offsite power; and
- Frequency of interfacing-system LOCA.

It should be noted that many events each contribute a small amount to the uncertainty in core damage frequency; no single event dominates the uncertainty.

3.3 Containment Performance Analysis

3.3.1 Results of Containment Performance Analysis

The Surry containment system uses a sub-atmospheric concept in which the containment building housing the reactor vessel, reactor coolant system, and secondary system's steam

generator is maintained at 10 psia. The containment building is a reinforced concrete structure with a volume of 1.8 million cubic feet. Its design basis pressure is 45 psig, whereas its mean failure pressure is estimated to be 126 psig. As previously discussed in Chapter 2, the method used to estimate accident loads and containment structural response for Surry made extensive use of expert judgment to interpret and supplement the limited data available.

The potential for early Surry containment failure is of major interest in this risk analysis. The principal threats identified in the Surry risk analyses (Ref. 3.2) as potentially leading to early containment failure are: (1) pressure loads, i.e., hydrogen combustion and direct containment heating due to ejection of molten core material via the rapid expulsion of hot steam and gases from the reactor coolant system; and (2) in-vessel steam explosions leading to vessel failure with the vessel upper head being ejected and impacting the containment building dome area (the so-called alpha-mode failure). Containment bypass (such as failures of reactor coolant system isolation check valves in the emergency core cooling system or steam generator tubes) is another serious threat to the integrity of the containment system.

The results of the Surry containment analysis are summarized in Figures 3.5 and 3.6. Figure 3.5 displays information in which the conditional probabilities of seven containment-related accident progression bins; e.g., VB, alpha, early CF, are presented for each of seven plant damage states; e.g., loss of offsite power. This information indicates that, on a plant damage state frequency-weighted average,* the conditional mean probability from internally initiated accidents of: (1) early containment failure is about 0.01, (2) late containment failure (basemat melt-through or leakage) is about 0.06, (3) direct bypass of the containment is about 0.12, and (4) no containment failure is 0.81. Figure 3.6 further displays the conditional probability distribution of early containment failure for each plant damage state to show the estimated range of uncertainties in these containment failure predictions. The important conclusions to be drawn from the information in Figures 3.5 and 3.6 are: (1) the mean conditional probability of early containment failure from internal events is low; i.e., less than 0.01; (2) the principal containment release

mechanism is bypass due to interfacing-system LOCA; and (3) external initiating events such as fire and earthquakes produce higher early and late containment failure probabilities.

The accident progression analyses performed for this report are particularly noteworthy in that, for core melt accidents at Surry, there is a high probability that the reactor coolant system (RCS) will be at relatively low pressures (less than 200 psi) at the time of molten core penetration of the lower reactor vessel head, thereby reducing the potential for direct containment heating (DCH). There are several reasons for concluding that the RCS will be at low system pressure such as: stuck-open PORVs, operator depressurization, failed reactor coolant pump seals, induced failures of RCS piping due to high temperatures, and the relative "mix" of plant damage states (i.e., for the frequency of plant damage states initially at high versus low RCS pressures). Accordingly, it has been concluded that the potential for early containment failure due to the phenomenon of DCH is less in the risk analyses underlying this report relative to previous studies (Ref. 3.10) on the basis of a combination of higher probabilities of low RCS pressures (discussed above), lower calculated pressures given direct containment heating, and greater estimated strength of the Surry containment building (Ref. 3.2). (See Section C.5 of Appendix C for additional discussion of DCH and why its importance is now less.)

Additional discussions on containment performance (for all studied plants) are provided in Chapter 9.

3.3.2 Important Plant Characteristics (Containment Performance)

Characteristics of the Surry plant design and operation that are unique to the containment building during core damage accidents include:

1. Subatmospheric Containment Operation

The Surry containment is maintained at a subatmospheric pressure (10 psia) during operation with a continual monitoring of the containment leakage. As a result, the likelihood of pre-existing leaks of significant size is negligible.

2. Post-Accident Heat Removal System

The Surry containment does not have fan cooler units that are qualified for post-accident heat removal as do some other PWR plants. Containment (and core) heat removal

*Each value in the column in Figure 3.5 labeled "All" is obtained by calculating the products of individual accident progression bin conditional probabilities for each plant damage state and the ratio of the frequency of that plant damage state to the total core damage frequency.

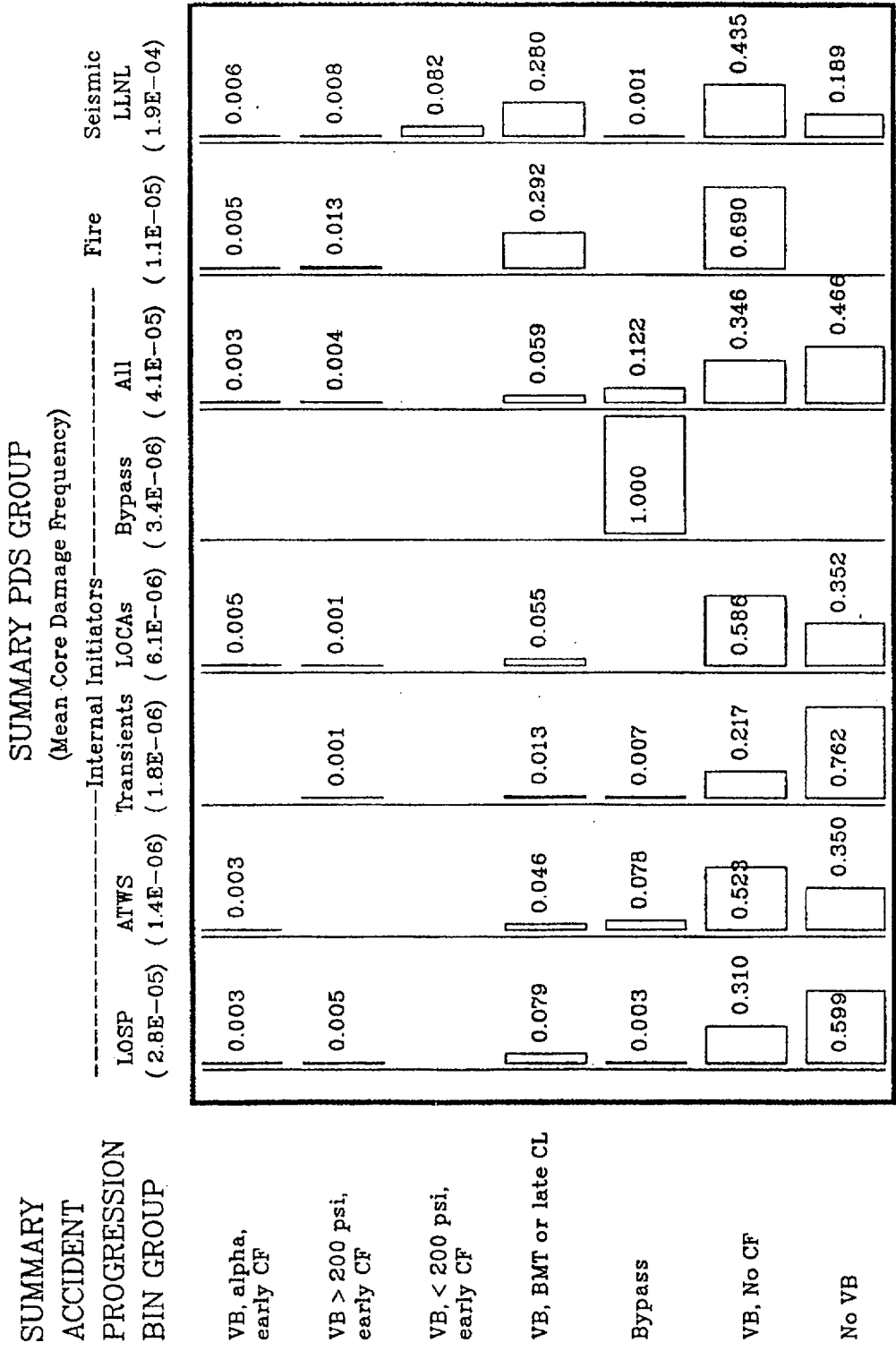

Key: BMT = Basemat Melt-Through
 CF = Containment Failure
 CL = Containment Leak
 VB = Vessel Breach

Figure 3.5 Conditional probability of accident progression bins at Surry.

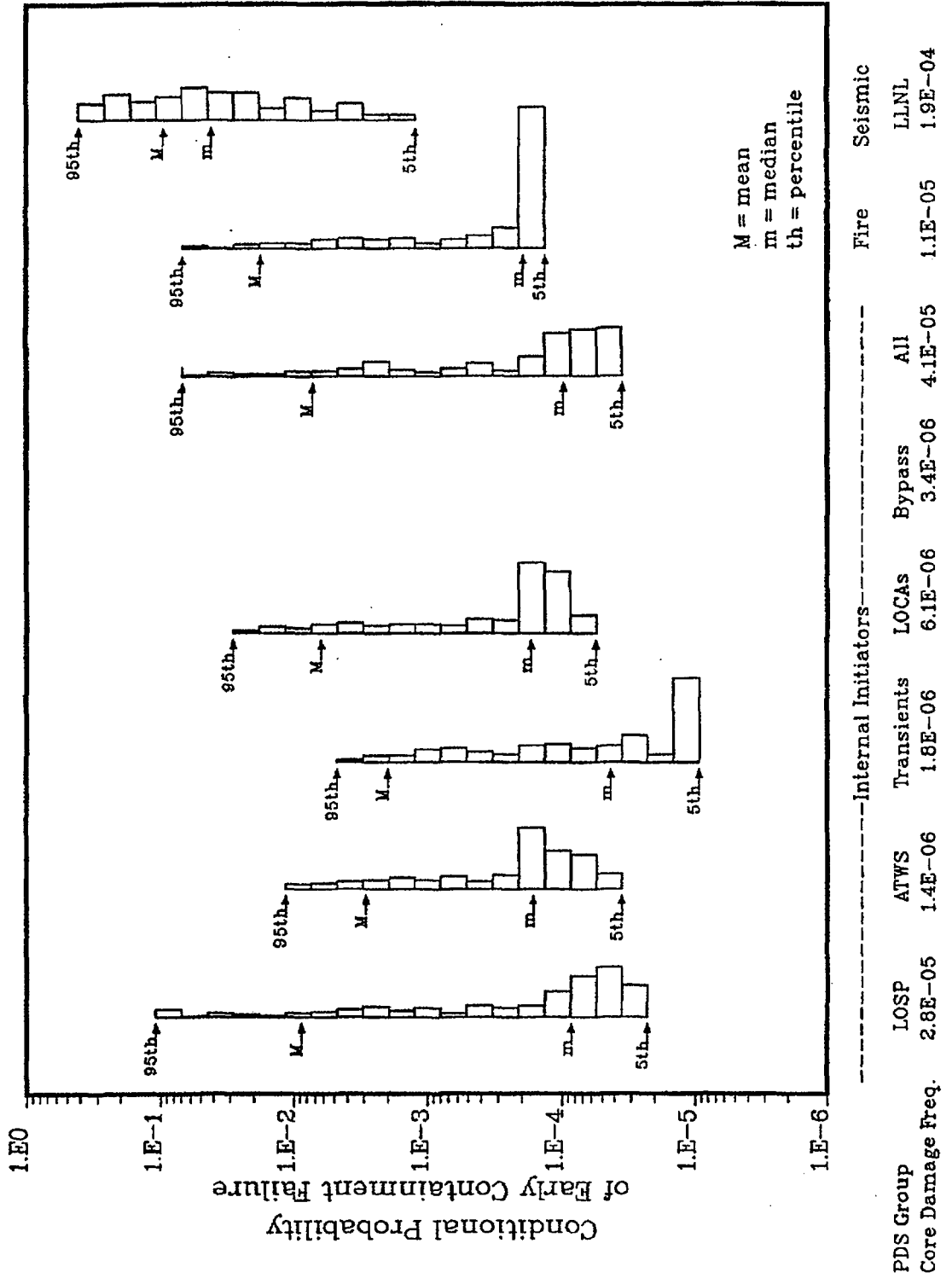

Figure 3.6 Conditional probability distributions for early containment failure at Surry.

3. Surry Plant Results

following an accident is provided by the containment spray recirculation system, whereas, in some PWR plants, post-accident heat removal can also be provided by the residual heat removal system heat exchangers in the emergency core cooling system.

3. Reactor Cavity Design

The reactor cavity area is not connected directly with the containment sump area. As a result, if the containment spray systems fail to operate during an accident, the reactor cavity will be relatively dry. The amount of water in the cavity can have a significant influence on phenomena that can occur after reactor vessel lower head failure, such as magnitude of containment pressurization from direct containment heating and post-vessel failure steam generation, the formation of coolable debris beds, and the retention of radioactive material released during core-concrete interactions.

4. Containment Building Design

The containment volume and high failure pressure provide considerable capacity for accommodation of severe accident pressure loads.

3.4 Source Term Analysis

3.4.1 Results of Source Term Analysis

In the Surry plant, the absolute frequency of an early failure of the containment* due to the loads produced in a severe accident is small. Although the absolute frequency of containment bypass is also small, for internal accident initiators it is greater than the absolute early failure frequency. Thus, bypass sequences are the more likely means of obtaining a large release of radioactive material. Figure 3.7 illustrates the distribution of source terms associated with the accident progression bin representing containment bypass. The range of release fractions is quite large, primarily as the result of the range of parameters provided by the experts. The magnitude of the release for many of the elemental groups is also large, indicative of a potentially serious accident. Typically, consequence analysis codes only predict the occurrence of early fatalities in the surrounding population when the release fractions of the vola-

tile groups (iodine, cesium, and tellurium) exceed approximately 10 percent (Ref. 3.11). For the bypass accident progression bin, the median value for the volatile radionuclides is approximately at the 10 percent level whereas for the early containment failure bin not shown, the releases are lower. The median values are somewhat smaller than 10 percent, but the ranges extend to approximately 30 percent.

In contrast to the large source term for the bypass bin, Figure 3.8 provides the range of source terms predicted for an accident progression bin involving late failure of the containment. The fractional release of radionuclides for this bin is several orders of magnitude smaller than for the bypass bin, except for iodine, which can be reevolved late in the accident. It should be noted that, for many of the elemental groups, the mean of the distribution falls above the 95th percentile value. For distributions that occur over a range of many orders of magnitude, sampling from the extreme tail of the distribution (at the high end) can dominate and cause this result.

Additional discussion on source term perspectives is provided in Chapter 10.

3.4.2 Important Plant Characteristics (Source Term)

Plant design features that affect the mode and likelihood of containment failure also influence the magnitude of the source term. These features were described in the previous section. Plant features that have a more direct influence on the source term are described in the following paragraphs.

1. Containment Spray System

The Surry plant has an injection spray system that uses the refueling water storage tank as a water source and a recirculation spray system that recirculates water from the containment sump. Sprays are an effective means for removing airborne radioactive aerosols. For sequences in which sprays operate throughout the accident, it is most likely that the containment will not fail and the leakage to the environment will be minor. If the containment does fail late in the accident following extended spray operation, analyses indicate that the release of aerosols will be extremely small. Even in a station blackout case with delayed recovery of sprays, condensation of steam from the air, and a subsequent hydrogen explosion that fails containment, Source Term Code Package (STCP) analyses indicate that spray operation results in substantially reduced source terms (Ref. 3.12).

*In this section, the absolute frequencies of early containment failure are discussed (i.e., including the frequencies of the plant damage states). This is in contrast to the previous section, which discusses conditional failure probabilities (i.e., given that a plant damage state occurs).

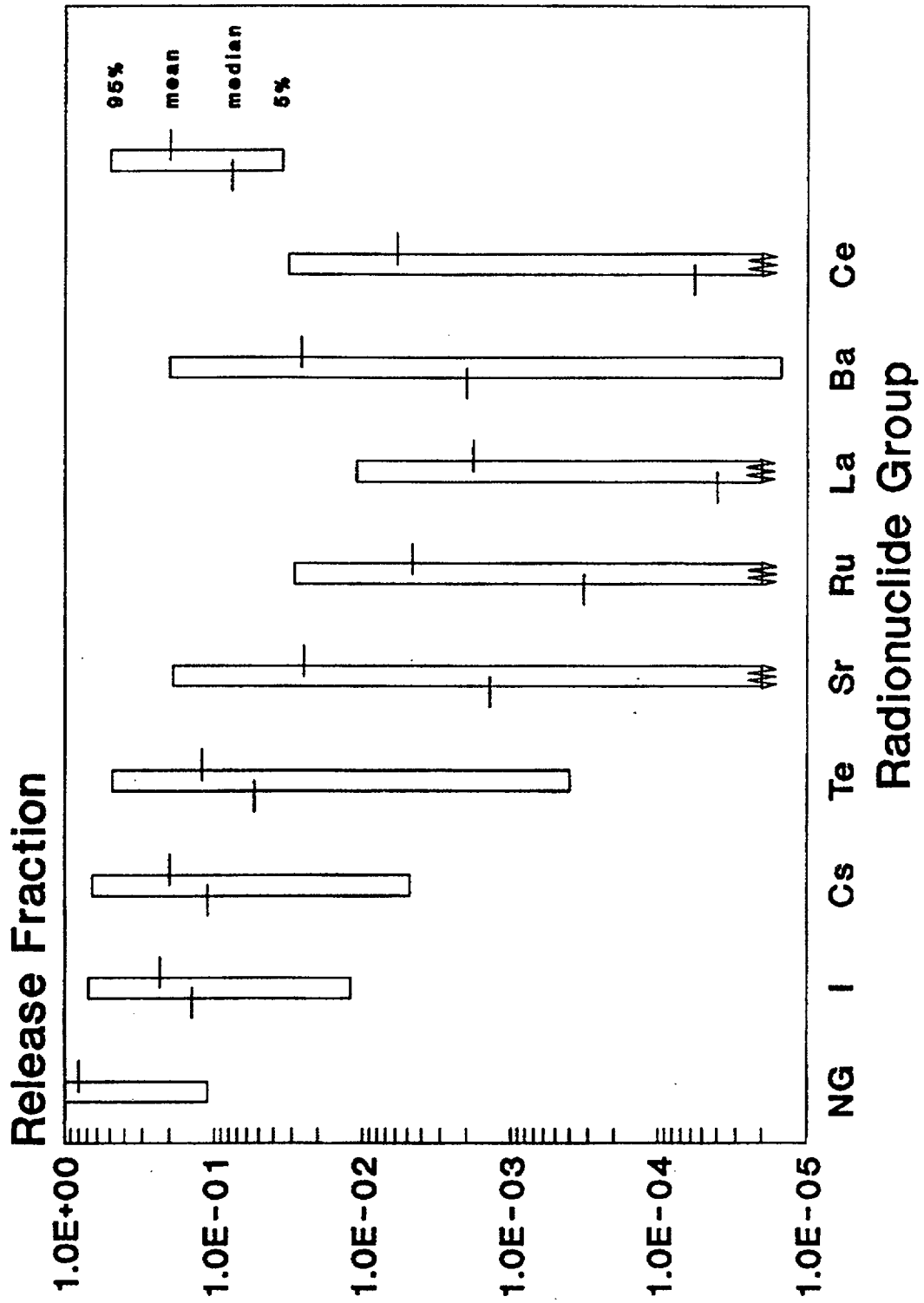

Figure 3.7 Source term distributions for containment bypass at Surry.

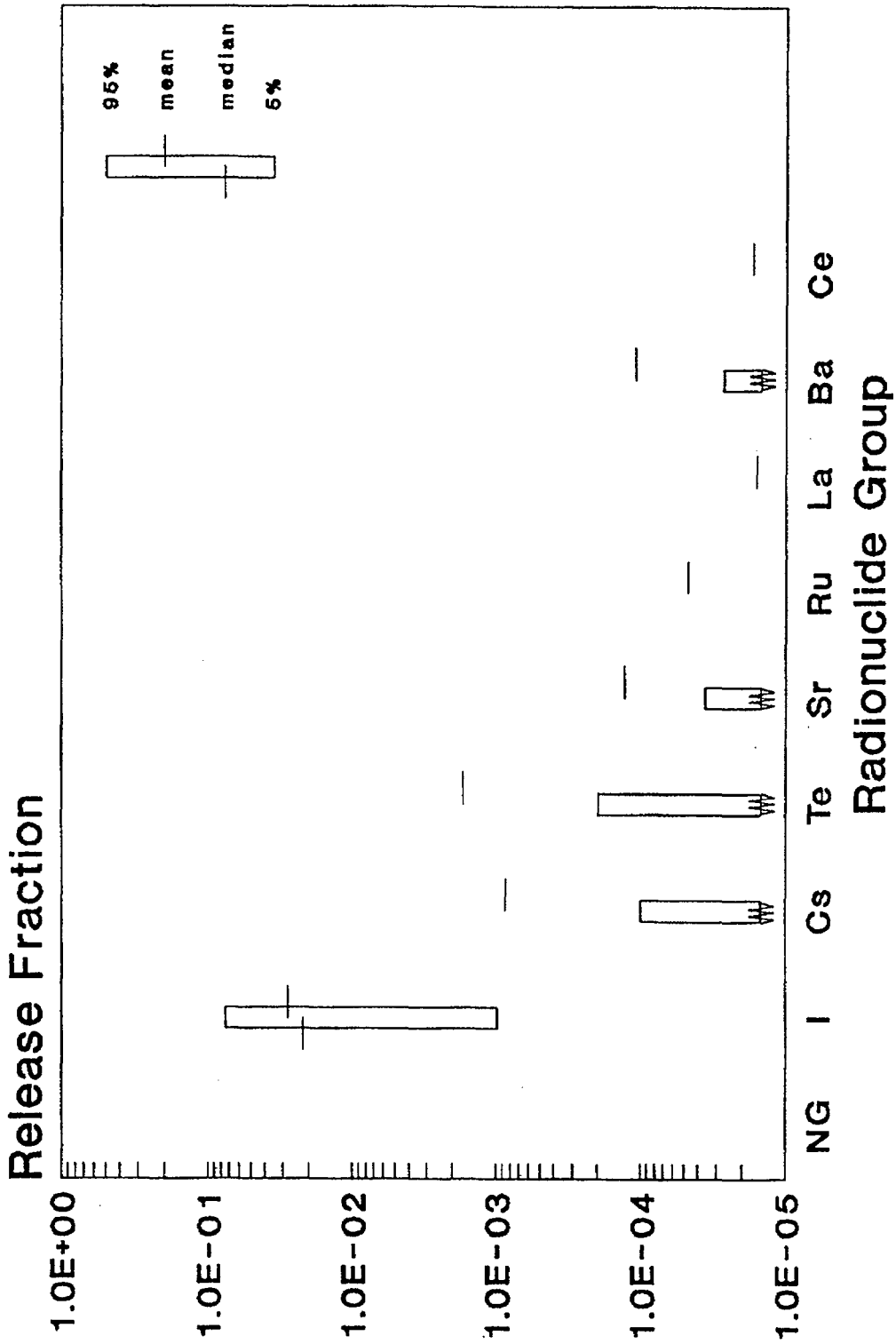

Figure 3.8 Source term distributions for late containment failure at Surry.

Sprays are not always effective in reducing the source term, however. The risk-dominant containment bypass sequences are largely unaffected by operation of the spray systems. Early containment failure scenarios involving high-pressure melt ejection have a component of the release that occurs almost simultaneously with containment failure, for which the sprays would not be effective.

In addition to removing aerosols from the atmosphere, containment sprays are an important source of water to the reactor cavity at Surry, which is otherwise dry. A coolable debris bed can be established in the cavity, preventing interactions between the hot core and concrete. If a coolable debris bed is not formed, a pool of water overlaying the hot core as it attacks concrete can effectively mitigate the release of radioactive material to the containment from this interaction.

2. Cavity Configuration

Water collecting on the floor of the Surry containment cannot flow into the reactor cavity. As a result, the cavity will be dry at the time of vessel meltthrough unless the containment spray system has operated. As discussed earlier, water in the cavity can have a substantial effect on mitigating or eliminating the release of radioactive material from the molten core-concrete interaction.

3.5 Offsite Consequence Results

Figures 3.9 and 3.10 display the frequency distributions in the form of graphical plots of complementary cumulative distribution functions (CCDFs) of four offsite consequence measures—early fatalities, latent cancer fatalities, and the 50-mile and entire site region population exposures (in person-rems). The CCDFs in Figures 3.9 and 3.10 include contributions from all source terms associated with reactor accidents caused by the internal initiating events and fire, respectively. Four CCDFs, namely, the 5th percentile, 50th percentile (median), 95th percentile, and the mean CCDFs, are shown for each consequence measure.

Surry plant-specific and site-specific parameters were used in the consequence analysis for these CCDFs. The plant-specific parameters included source terms and their frequencies, the licensed thermal power (2441 MWt) of the reactor, and the approximate physical dimensions of the power plant building complex. The site-specific param-

eters included exclusion area radius (520 meters), meteorological data for 1 full year collected at the site meteorological tower, the site region population distribution based on the 1980 census data, topography (fraction of the area that is land—the remaining fraction is assumed to be water), land use, agricultural practice and productivity, and other economic data for up to 1,000 miles from the Surry plant.

The consequence estimates displayed in these figures have incorporated the benefits of the following protective measures: (1) evacuation of 99.5 percent of the population within the 10-mile plume exposure pathway emergency planning zone (EPZ), (2) early relocation of the remaining population only from the heavily contaminated areas both within and outside the 10-mile EPZ, and (3) decontamination, temporary interdiction, or condemnation of land, property, and foods contaminated above acceptable levels.

The population density within the Surry 10-mile EPZ is about 230 persons per square mile. The average delay time before evacuation (after a warning prior to radionuclide release) from the 10-mile EPZ and average effective evacuation speed used in the analyses were derived from information contained in a utility-sponsored Surry evacuation time estimate study (Ref. 3.13) and the NRC requirements for emergency planning.

The results displayed in Figures 3.9 and 3.10 are discussed in Chapter 11.

3.6 Public Risk Estimates

3.6.1 Results of Public Risk Estimates

A detailed description of the results of the Surry risk analysis is provided in Reference 3.2. For this summary report, results are provided for the following measures of public risk:

- Early fatality risk,
- Latent cancer fatality risk,
- Population dose within 50 miles of the site,
- Population dose within the entire site region,
- Individual early fatality risk in the population within 1 mile of the Surry exclusion area boundary, and
- Individual latent cancer fatality risk in the population within 10 miles of the Surry site.

3. Surry Plant Results

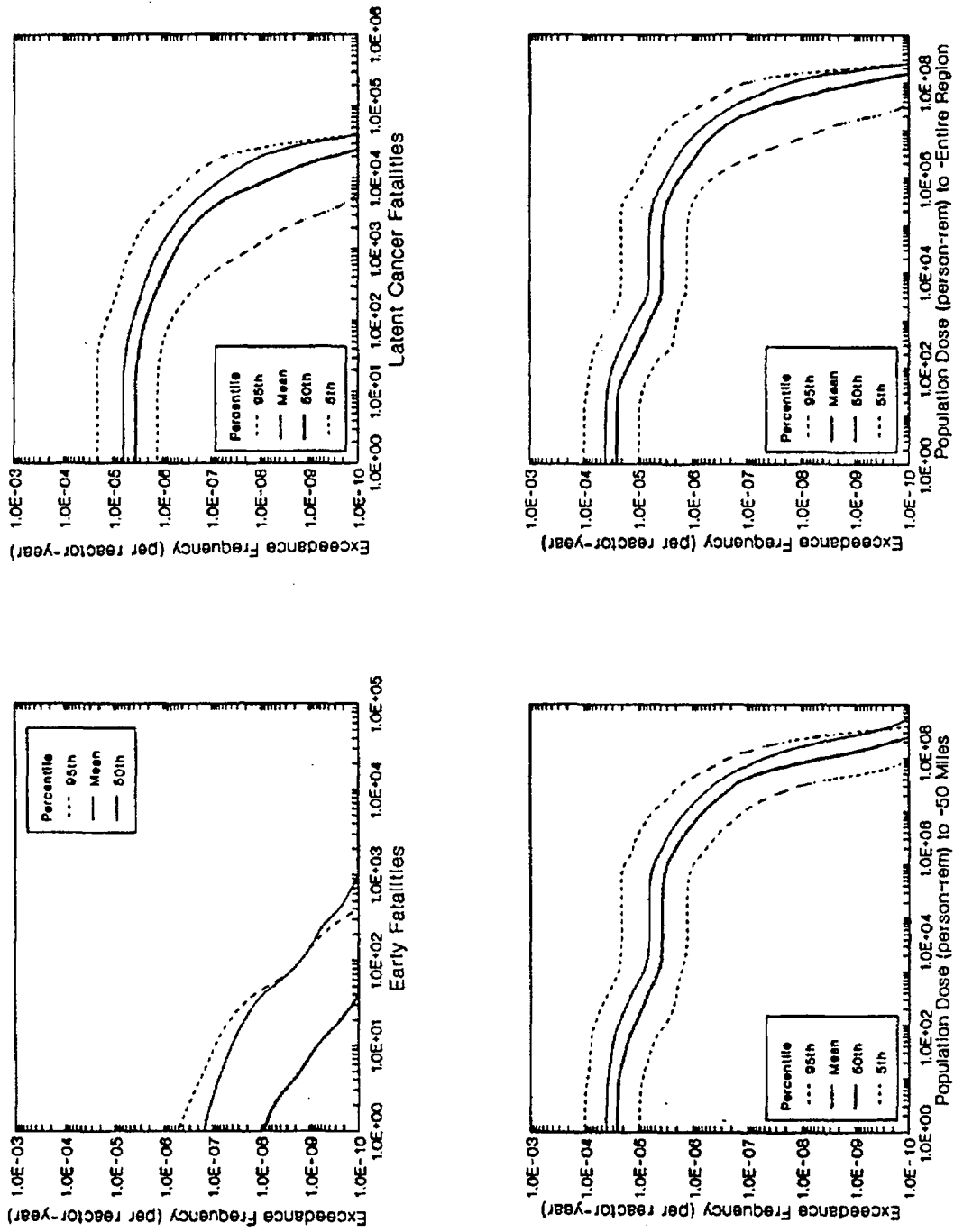

Note: As discussed in Reference 3.4, consequences at frequencies estimated at or below 1E-7 per reactor year should be viewed with caution because of the potential impact of events not studied in the risk analyses.

Figure 3.9 Frequency distributions of offsite consequence measures at Surry (internal initiators).

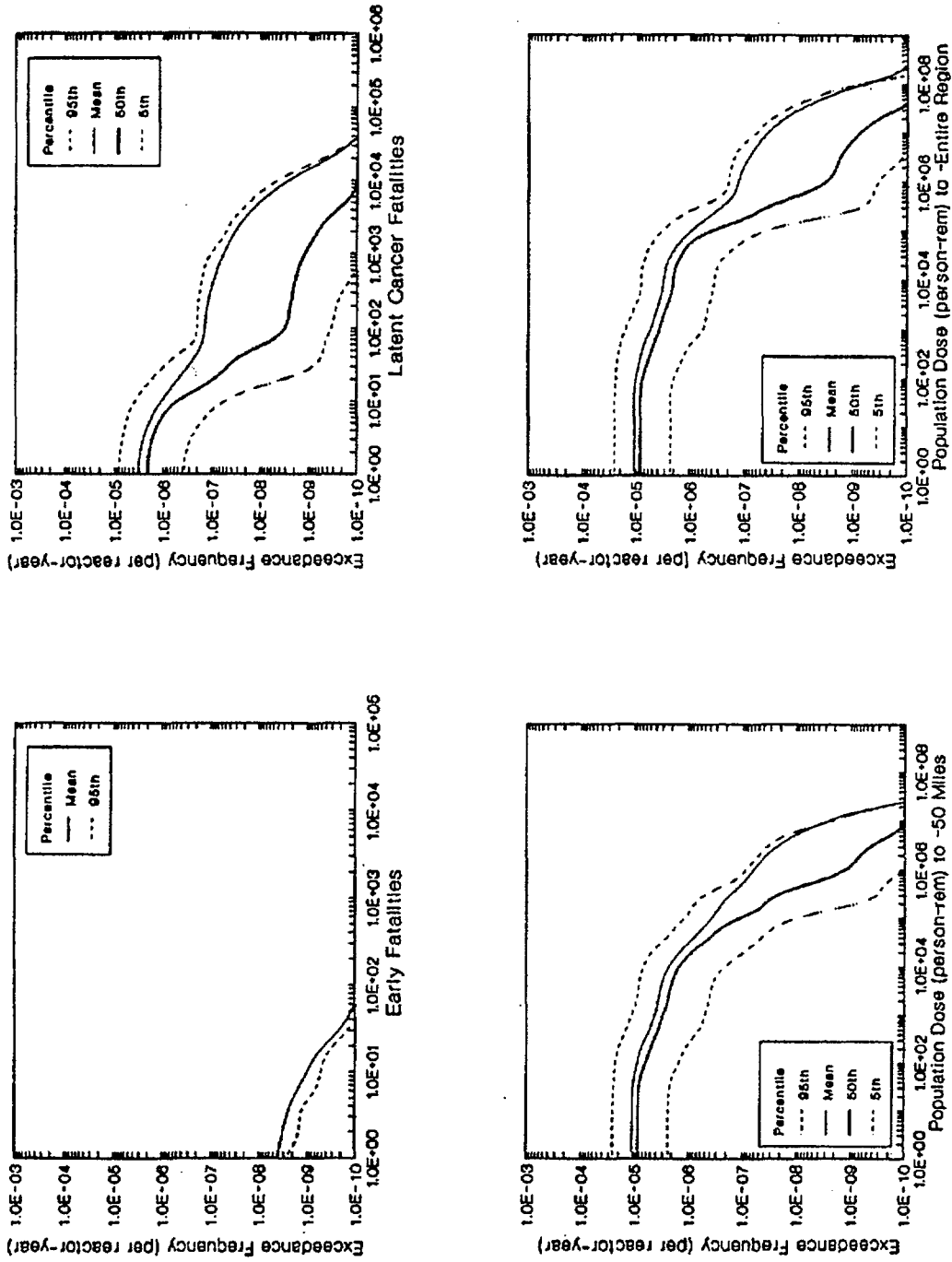

Note: As discussed in Reference 3.4, consequences at frequencies estimated at or below 1E-7 per reactor year should be viewed with caution because of the potential impact of events not studied in the risk analyses.

Figure 3.10 Frequency distributions of offsite consequence measures at Surry (fire initiators).

3. Surry Plant Results

The first four of the above measures are commonly used measures in nuclear power plant risk studies. The last two are those used to compare with the NRC safety goals (Ref. 3.14).

3.6.1.1 Internally Initiated Accident Sequences

The results of the risk studies using the above measures are provided in Figures 3.11 through 3.13 for internally initiated accidents. The figures display the variabilities in mean risks estimated from the meteorology-averaged conditional mean values of the consequence measures. For the first two measures, the results of the first risk study of Surry, the Reactor Safety Study (Ref. 3.3), are also provided. As may be seen, both the early fatality risks and latent cancer fatality risks are lower than those of the Reactor Safety Study. The early fatality risk distribution, however, has a longer tail at the low end indicating a belief by the experts that there is a finite probability that risks may be orders of magnitude lower than those of the Reactor Safety Study. The risks of population dose within 50 miles of the plant site as well as within the entire site region are very low. Individual early fatality and latent cancer fatality risks are well below the NRC safety goals.

For the early and latent cancer fatality risk measures, the Reactor Safety Study values lie in the upper portions of the present risk range. This is because of the current estimates of better containment performance and source terms. The estimated probability of early containment failure in this study is significantly lower than the Reactor Safety Study values. The source term ranges of the Reactor Safety Study are comparable with the upper portions of the present study. The median core damage frequencies of the two studies, however, are about the same ($2.3E-5$ per reactor year for this study compared to $4.6E-5$ per reactor year for the Reactor Safety Study). A more detailed comparison between results is provided in Chapters 12.

The risk results shown in Figure 3.11 have been analyzed to determine the relative contributions of plant damage states and containment-related accident progression bins to mean risk. The results of this analysis are provided in Figures 3.14 and 3.15. As may be seen, the mean early and latent cancer fatality risks of the Surry plant are principally due to accidents that bypass the containment building (interfacing-system LOCA (Event V) and steam generator tube ruptures).

Details of these accident sequences are provided in Section 3.2.1.1. It should be noted from these discussions that for the steam generator tube rupture accident, if corrective or protective actions are taken (e.g., alternative sources of water are made available, emergency response is initiated*) before the refueling water storage tank water is totally depleted, i.e., within about a 10-hour period after start of the accident, risks from this accident may be substantially reduced.

3.6.1.2 Externally Initiated Accident Sequences

The Surry plant has been analyzed for two externally initiated accidents: earthquakes and fire (see Section 3.2.1.2). The fire risk analysis has been performed, including estimates of consequences and risk, while the seismic analysis has been conducted up to the containment performance (as discussed in Chapter 2). Sensitivity analyses of seismic risk at Surry are provided in Reference 3.2.

Results of fire risk analysis (variabilities in mean risks estimated from meteorology-averaged conditional mean values of the consequence measures) of Surry are shown in Figures 3.16 through 3.18 for the early fatality, latent cancer fatality, population dose (within 50 miles of the site and within the entire site region), and individual early and latent cancer fatality risks. As can be seen, the risks from fire are substantially lower than those from internally initiated events.

Major contributors to early and latent cancer fatality risks are shown in Figure 3.19. (Note that there are no bypass initiating events in the fire plant damage state.) The most risk-important sequence is a fire in the emergency switchgear room that leads to loss of ac power throughout the station. The principal risk-important accident progression bin is early containment failure with the reactor coolant system at high pressure (>200 psia) at vessel breach leading to direct containment heating.

Additional discussion of risk perspectives (for all five plants studied) is provided in Chapter 12.

3.6.2 Important Plant Characteristics (Risk)

The plant characteristics discussed in Section 3.2.2 that were important in the analysis of core damage frequency were primarily related to the station blackout accident sequences and have not been found to be important in the risk analysis.

*See Chapter 11 for sensitivity of offsite consequences to alternative modes of emergency response.

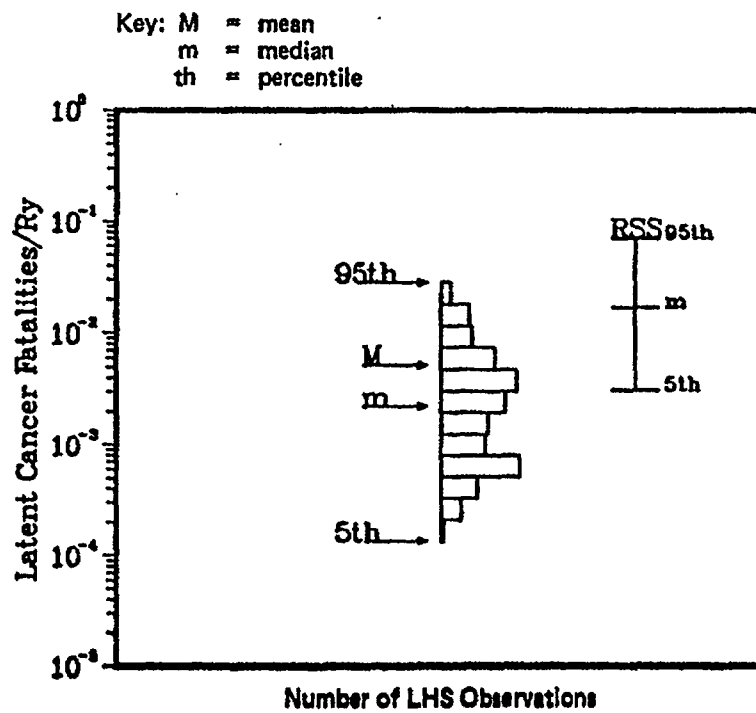
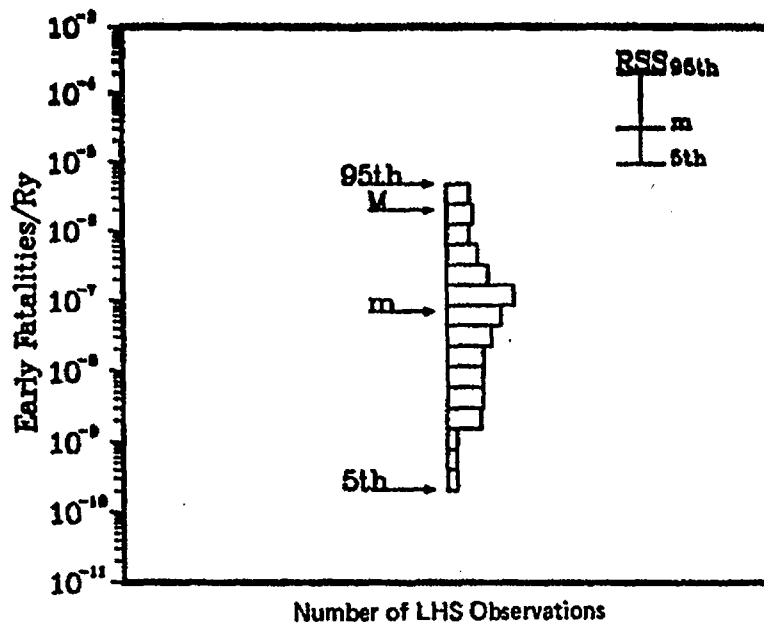

Note: As discussed in Reference 3.4, estimated risks at or below $1E-7$ per reactor year should be viewed with caution because of the potential impact of events not studied in the risk analyses.

Figure 3.11 Early and latent cancer fatality risks at Surry (internal initiators).

3. Surry Plant Results

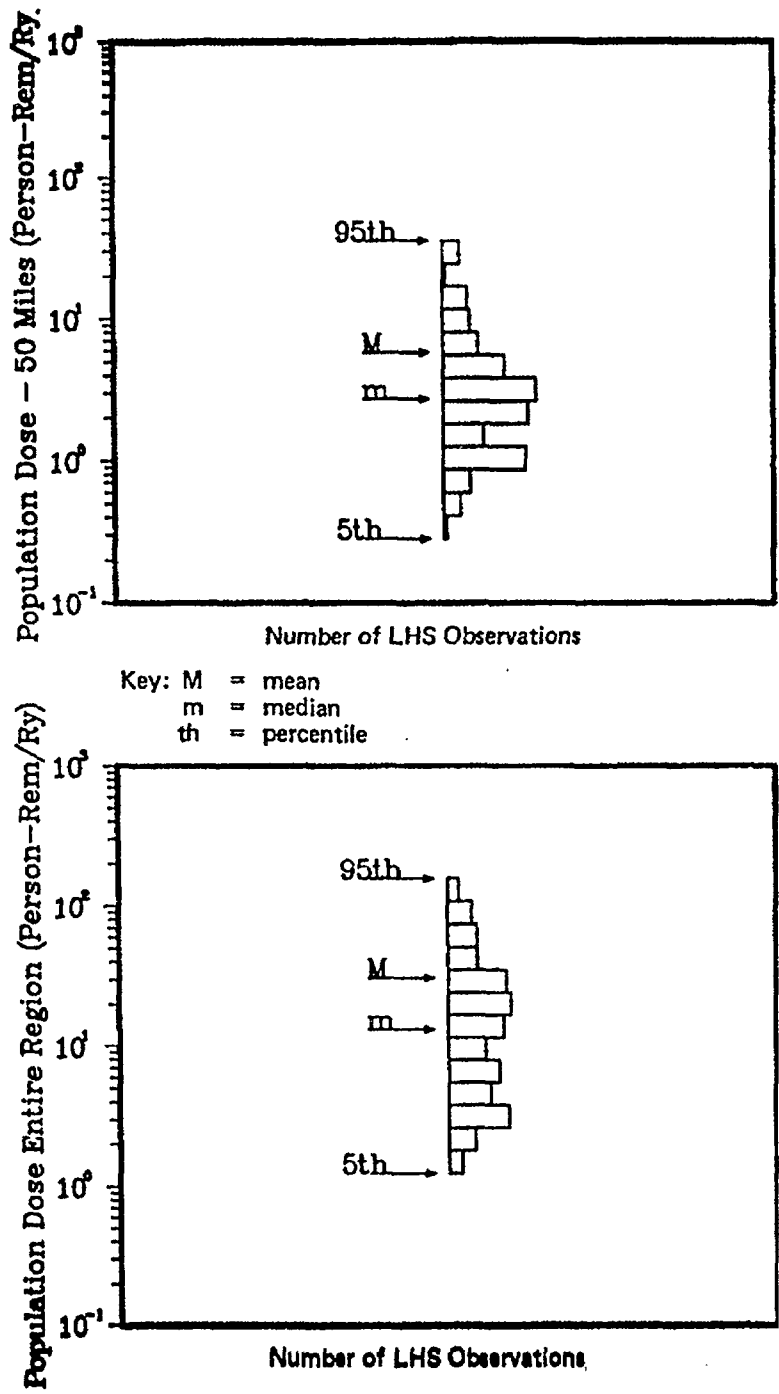

Note: As discussed in Reference 3.4, estimated risks at or below $1E-7$ per reactor year should be viewed with caution because of the potential impact of events not studied in the risk analyses.

Figure 3.12 Population dose risks at Surry (internal initiators).

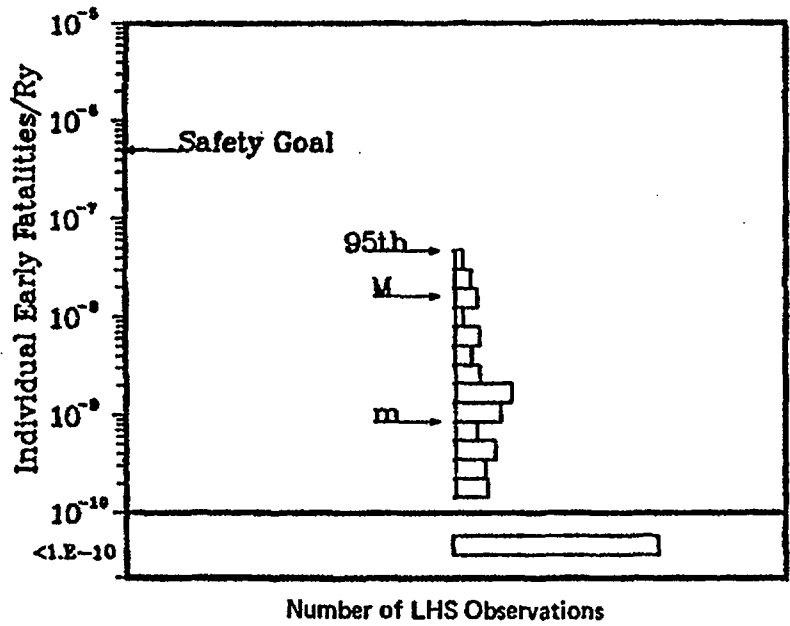

Key: M = mean
 m = median
 th = percentile

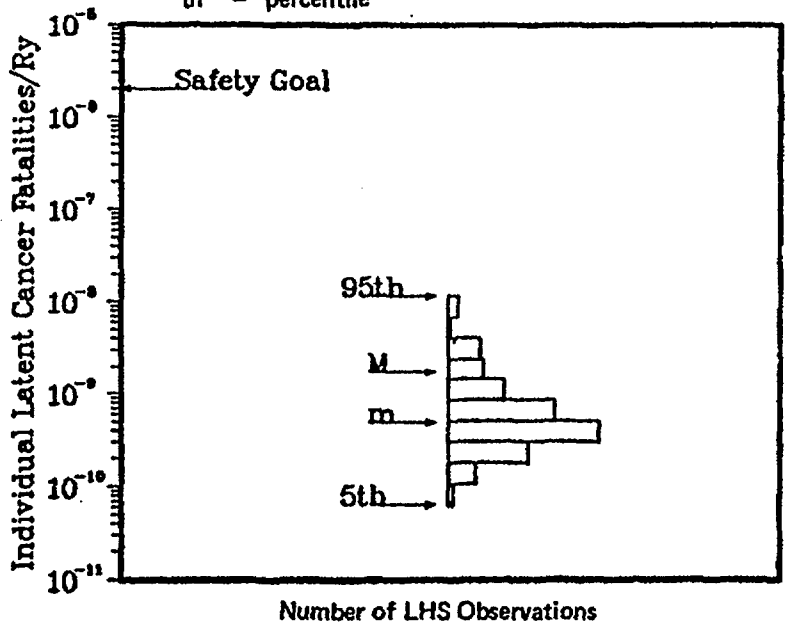

Note: As discussed in Reference 3.4, estimated risks at or below $1E-7$ per reactor year should be viewed with caution because of the potential impact of events not studied in the risk analyses.

Figure 3.13 Individual early and latent cancer fatality risks at Surry (internal initiators).

3. Surry Plant Results

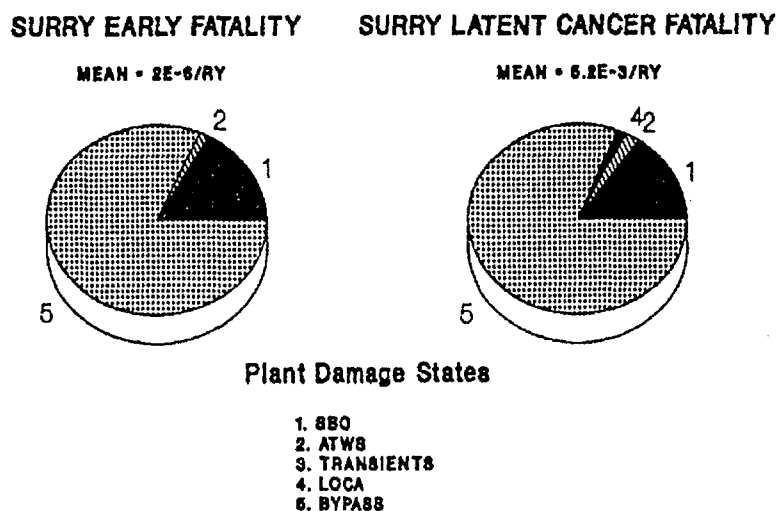

Figure 3.14 Major contributors (plant damage states) to mean early and latent cancer fatality risks at Surry (internal initiators).

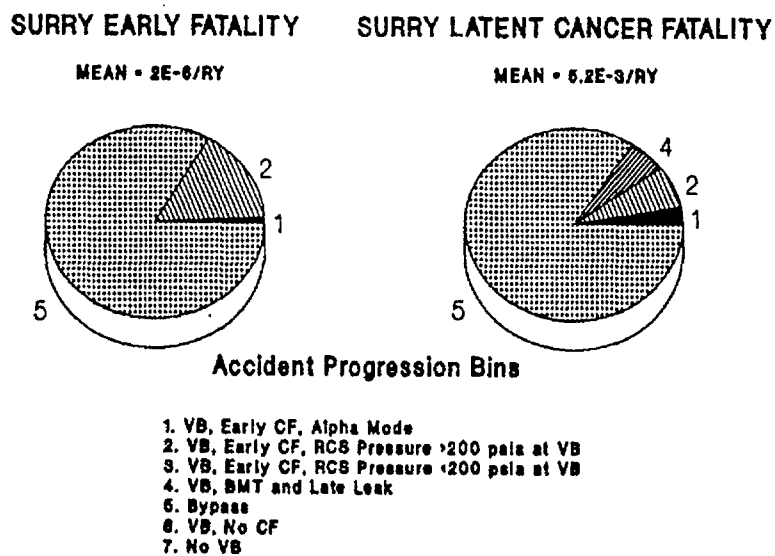
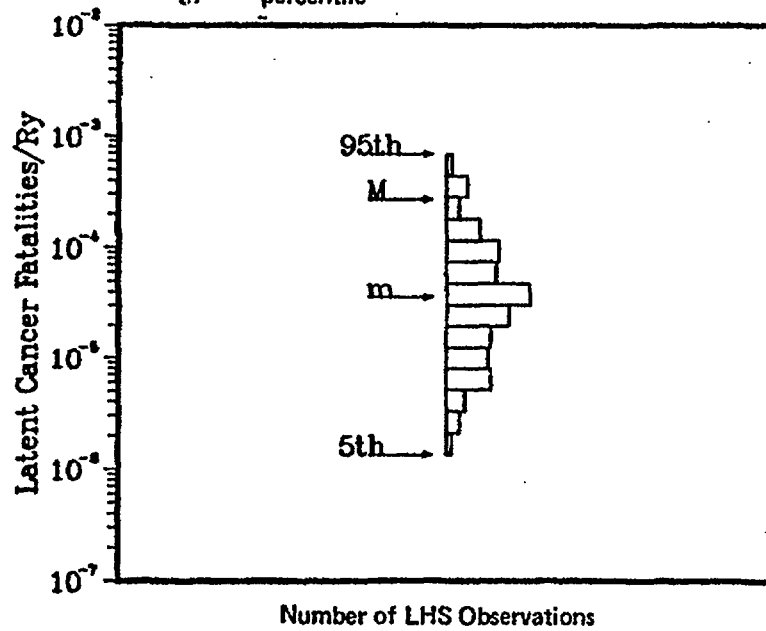
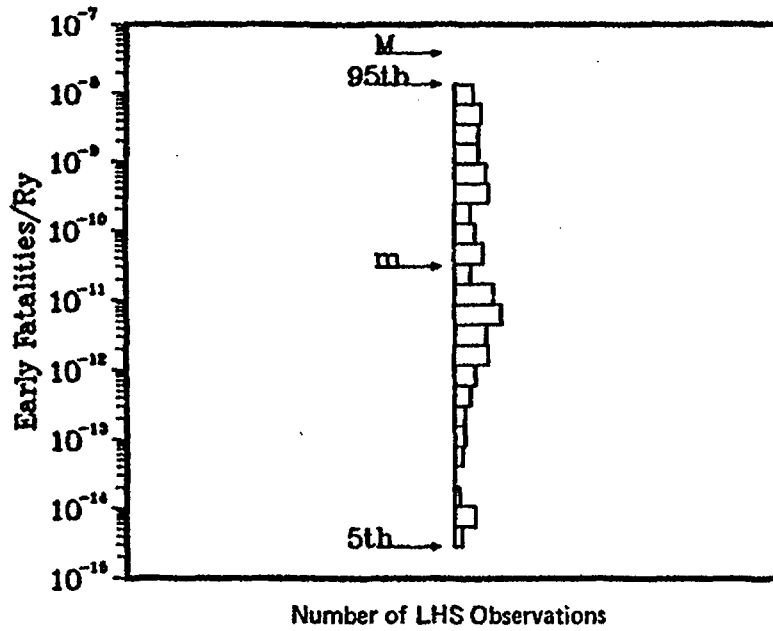

Figure 3.15 Major contributors (accident progression bins) to mean early and latent cancer fatality risks at Surry (internal initiators).



Note: As discussed in Reference 3.4, estimated risks at or below $1E-7$ per reactor year should be viewed with caution because of the potential impact of events not studied in the risk analyses.

Figure 3.16 Early and latent cancer fatality risks at Surry (fire initiators).

3. Surry Plant Results

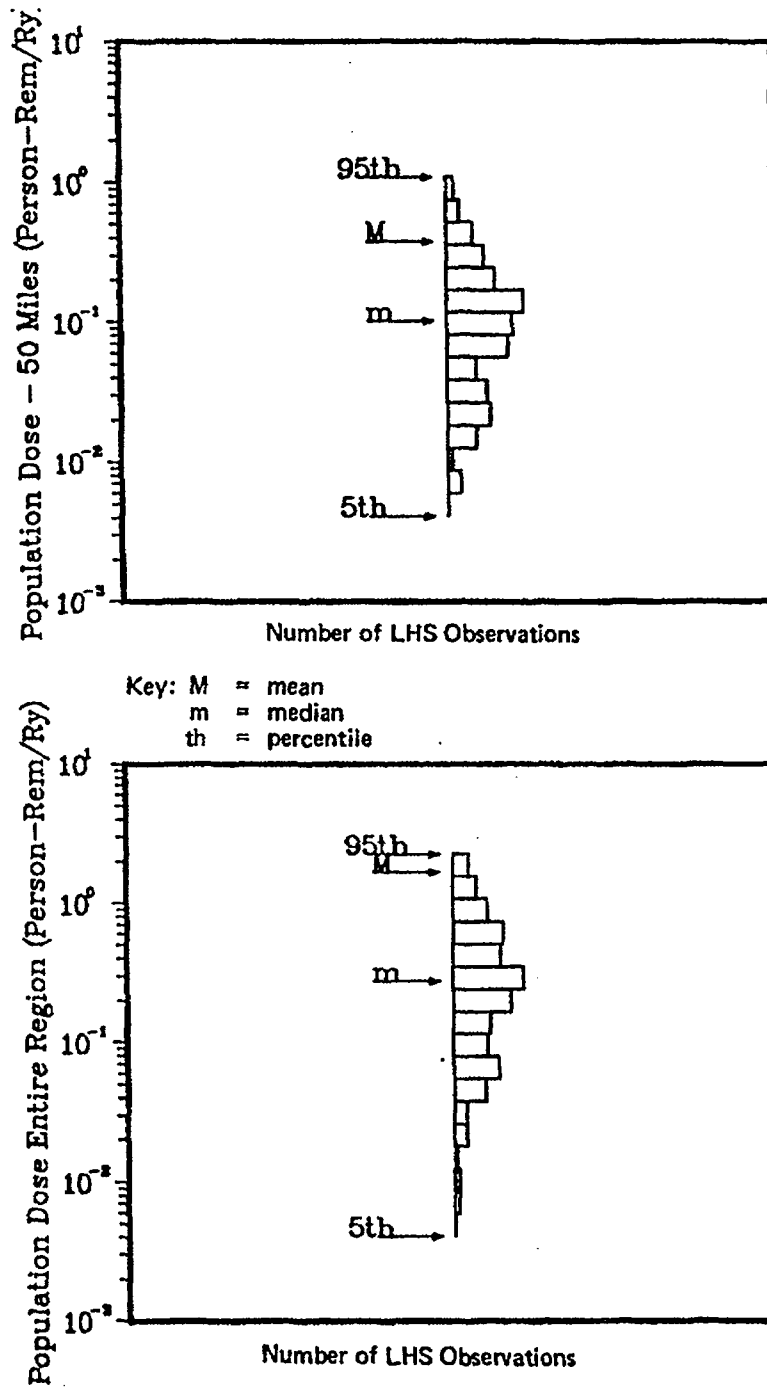

Note: As discussed in Reference 3.4, estimated risks at or below $1E-7$ per reactor year should be viewed with caution because of the potential impact of events not studied in the risk analyses.

Figure 3.17 Population dose risks at Surry (fire initiators).

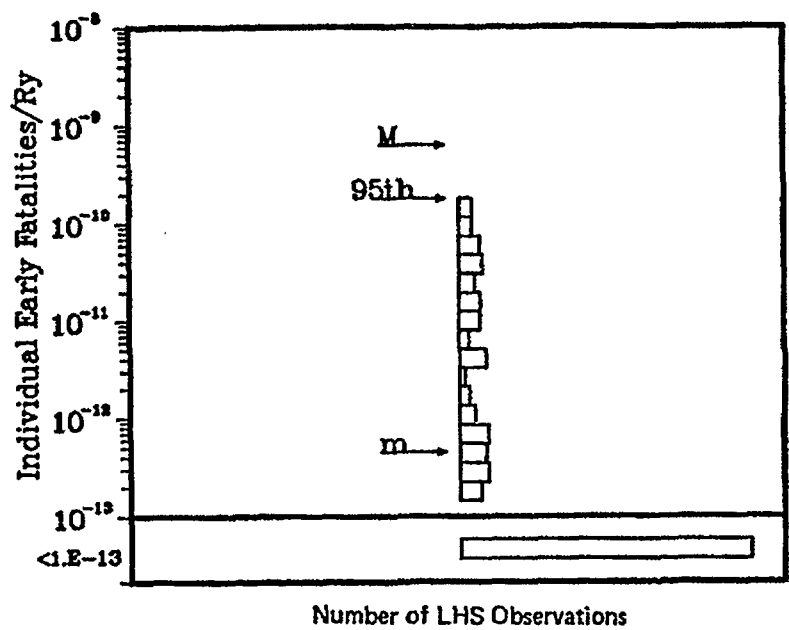

Key: M = mean
 m = median
 th = percentile

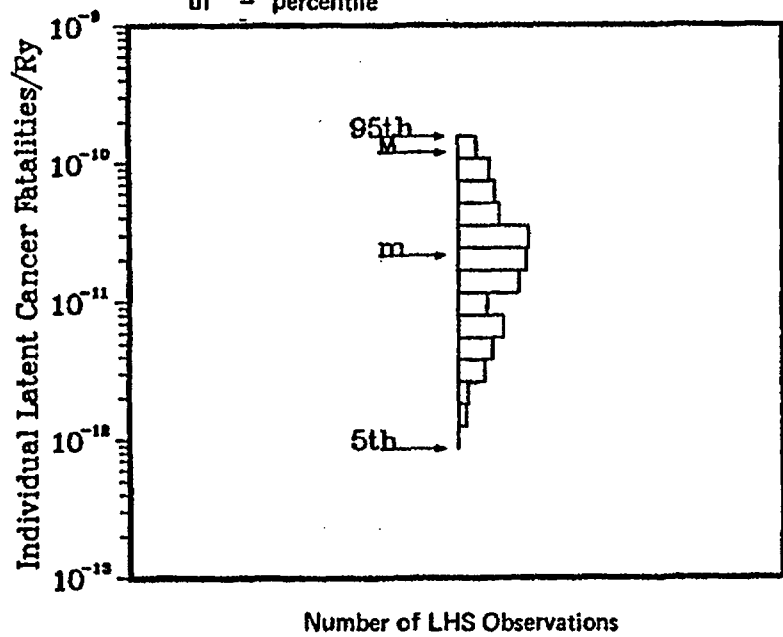

Note: As discussed in Reference 3.4, estimated risks at or below $1E-7$ per reactor year should be viewed with caution because of the potential impact of events not studied in the risk analyses.

Figure 3.18 Individual early and latent cancer fatality risks at Surry (fire initiators).

3. Surry Plant Results

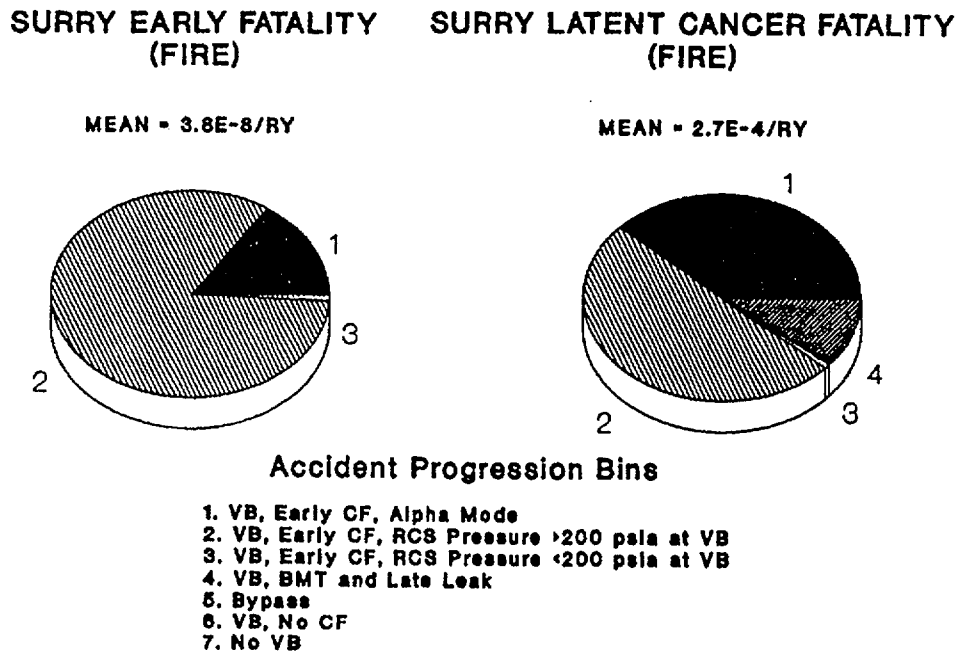

Figure 3.19 Major contributors (accident progression bins) to mean early and latent cancer fatality risks at Surry (fire initiators).

That is, because of the high consequences of the containment bypass sequences and low frequency of early containment failures, Event V and SGTR were more important risk contributors in the Surry analysis. The following general observations can be made from the risk results:

- The Surry containment appears robust, with a low conditional probability of failure (early or late). This is responsible, to a large extent, for the low risk estimates for the Surry plant. (In comparison with other plants studied in this report, risks for Surry are relatively high; but, in the absolute sense, these risks are very low and are well below NRC safety goals, as can be seen in Chapter 12.)
- Early fatality risk is dominated by bypass accidents, primarily from an interfacing-system LOCA. This accident leads to rapid core damage; the radioactive release is assessed to take place before evacuation is complete. Steam generator tube rupture accident sequences with stuck-open SRVs result in very late core melt; evacuation is assessed to be complete before the release is estimated to occur.
- The configuration of low-pressure piping outside the containment leads to a high probability that the release from an interfacing-system LOCA would be partially scrubbed by overlaying water. If the release were to take place without such scrubbing, the contribution to early fatality risk would be higher.
- Depressurization of the reactor coolant system by deliberate or inadvertent means plays an important role in the progression of severe accidents at Surry in that it decreases the probability of containment failure by high-pressure melt ejection and direct containment heating.
- Risks from accidents initiated by fires are dominated by early containment failures and are estimated to be much lower than those from internally initiated accidents.

REFERENCES FOR CHAPTER 3

- 3.1 R. C. Bertucio and J. A. Julius, "Analysis of Core Damage Frequency: Surry Unit 1," Sandia National Laboratories, NUREG/CR-4550, Vol. 3, Revision 1, SAND86-2084, April 1990.
- 3.2 R. J. Breeding et al., "Evaluation of Severe Accident Risks: Surry Unit 1," Sandia National Laboratories, NUREG/CR-4551, Vol. 3, Revision 1, SAND86-1309, October 1990.
- 3.3 USNRC, "Reactor Safety Study—An Assessment of Accident Risks in U.S. Commercial Nuclear Power Plants," WASH-1400 (NUREG-75/014), October 1975.
- 3.4 H. J. C. Kouts et al., "Special Committee Review of the Nuclear Regulatory Commission's Severe Accident Risks Report (NUREG-1150)," NUREG-1420, August 1990.
- 3.5 A. Kolaczkowski and A. Payne, "Station Blackout Accident Analyses," Sandia National Laboratories, NUREG/CR-3226, SAND82-2450, May 1983.
- 3.6 D. L. Bernreuter et al., "Seismic Hazard Characterization of 69 Nuclear Power Sites East of the Rocky Mountains," Lawrence Livermore National Laboratory, NUREG/CR-5250, Vols. 1-8, UCID-21517, January 1989.
- 3.7 Seismicity Owners Group and Electric Power Research Institute, "Seismic Hazard Methodology for the Central and Eastern United States," EPRI NP-4726, July 1986.
- 3.8 U.S. Code of Federal Regulations, Appendix R, "Fire Protection Program for Nuclear Power Facilities Operating Prior to January 1, 1979," to Part 50, "Domestic Licensing of Production and Utilization Facilities," of Chapter I, Title 10, "Energy."
- 3.9 T. A. Wheeler et al., "Analysis of Core Damage Frequency from Internal Events: Expert Judgment Elicitation," Sandia National Laboratories, NUREG/CR-4550, Vol. 2, SAND86-2084, April 1989.
- 3.10 USNRC, "Reactor Risk Reference Document," NUREG-1150, Vols. 1-3, Draft for Comment, February 1987.
- 3.11 G. D. Kaiser, "The Implications of Reduced Source Terms for Ex-Plant Consequence Modeling," Executive Conference on the Ramifications of the Source Term (Charleston, SC), March 12, 1985.
- 3.12 R. S. Denning et al., "Radionuclide Release Calculations for Selected Severe Accident Scenarios—PWR, Subatmospheric Containment Design," Battelle Columbus Division, NUREG/CR-4624, Vol. 3, BMI-2139, July 1986.
- 3.13 P. R. C. Voorhees, "Surry Nuclear Power Station Estimation of Evacuation Times," prepared for Virginia Power Company, March 1981.
- 3.14 USNRC, "Safety Goals for the Operation of Nuclear Power Plants; Policy Statement," *Federal Register*, Vol. 51, p. 30028, August 21, 1986.

4. PEACH BOTTOM PLANT RESULTS

4.1 Summary Design Information

The Peach Bottom Atomic Power Station is a General Electric boiling water reactor (BWR-4) unit of 1065 MWe capacity housed in a Mark I containment constructed by Bechtel Corporation. Peach Bottom Unit 2, analyzed in this study, began commercial operation in July 1974 under the operation of Philadelphia Electric Company (PECo). Some important system design features of the Peach Bottom plant are described in Table 4.1. A general plant schematic is provided in Figure 4.1.

This chapter provides a summary of the results obtained in the detailed risk analyses underlying this report (Refs. 4.1 and 4.2). A discussion of perspectives with respect to these results is provided in Chapters 8 through 12.

4.2 Core Damage Frequency Estimates

4.2.1 Summary of Core Damage Frequency Estimates

The core damage frequency and risk analyses performed for this study considered accidents initiated by both internal and external events (Refs. 4.1 and 4.2). The core damage frequency results obtained from internal events are displayed in graphical form as a histogram in Figure 4.2 (Section 2.2.2 discusses histogram development). The core damage frequency results obtained from internal and external events are provided in tabular form in Table 4.2.

The Peach Bottom plant was previously analyzed in the Reactor Safety Study (RSS) (Ref. 4.3). The RSS calculated a total point estimate core damage frequency from internal events of $2.6E-5$ per year. This study calculated a total median core damage frequency from internal events of $1.9E-6$ per year with a corresponding mean value of $4.5E-6$. For a detailed discussion of, and insights into, the comparison between this study and the RSS, see Chapter 8.

4.2.1.1 Internally Initiated Accident Sequences

A detailed description of accident sequences important at the Peach Bottom plant is provided in Reference 4.1. For this summary report, the accident sequences described in that report have been grouped into four summary plant damage states. These are:

- Station blackout,
- Anticipated transient without scram (ATWS),
- Loss-of-coolant accidents (LOCAs), and
- Transients other than station blackout and ATWS.

The relative contributions of these groups to mean internal-event core damage frequency at Peach Bottom are shown in Figure 4.3. From Figure 4.3, it may be seen that station blackout sequences as a class are the largest contributor to mean core damage frequency. It should be noted that the plant configuration (as analyzed for this study) does not reflect modifications that may be required in response to the station blackout rule.

Within the general class of station blackout accidents, the more probable combinations of failures leading to core damage are:

- Loss of onsite and offsite ac power results in the loss of all core cooling systems (except high-pressure coolant injection (HPCI) and reactor core isolation cooling (RCIC), both of which are ac independent in the short term) and all containment heat removal systems. HPCI or RCIC (or both) systems function but ultimately fail at approximately 10 hours because of battery depletion or other late failure modes (e.g., loss of room cooling effects). Core damage results in approximately 13 hours as a result of coolant boiloff.
- Loss of offsite power occurs followed by a subsequent failure of all onsite ac power. The diesel generators fail to start because of failure of all the vital batteries. Without ac and dc power, all core cooling systems (including HPCI and RCIC) and all containment heat removal systems fail. Core damage begins in approximately 1 hour as a result of coolant boiloff.
- Loss of offsite power occurs followed by a subsequent failure of a safety relief valve to reclose. All onsite ac power fails because the diesel generators fail to start and run from a variety of faults. The loss of all ac power fails most of the core cooling systems and all the containment heat removal systems. HPCI and RCIC (which are ac independent) are available and either or both initially function

4. Peach Bottom Plant Results

Table 4.1 Summary of design features: Peach Bottom Unit 2.

| | |
|-------------------------------|--|
| 1. Coolant Injection Systems | <ul style="list-style-type: none">a. High-pressure coolant injection system provides coolant to the reactor vessel during accidents in which system pressure remains high, with 1 train and 1 turbine-driven pump.b. Reactor core isolation cooling system provides coolant to the reactor vessel during accidents in which system pressure remains high, with 1 train and 1 turbine-driven pump.c. Low-pressure core spray system provides coolant to the reactor vessel during accidents in which vessel pressure is low, with 2 trains and 4 motor-driven pumps.d. Low-pressure coolant injection system provides coolant to the reactor vessel during accidents in which vessel pressure is low, with 2 trains and 4 pumps.e. High-pressure service water crosstie system provides coolant makeup source to the reactor vessel during accidents in which normal sources of emergency injection have failed (low RPV pressure), with 1 train and 4 pumps for crosstie.f. Control rod drive system provides backup source of high-pressure injection, with 2 pumps/210 gpm (total)/1,100 psia.g. Automatic depressurization system for depressurizing the reactor vessel to a pressure at which the low-pressure injection systems can inject coolant to the reactor vessel: 5 ADS relief valves/capacity 820,000 lb/hr. In addition, there are 6 non-ADS relief valves. |
| 2. Key Support Systems | <ul style="list-style-type: none">a. dc power with up to approximately 10–12-hour station batteries.b. Emergency ac power from 4 diesel generators shared between 2 units.c. Emergency service water provides cooling water to safety systems and components shared by 2 units. |
| 3. Heat Removal Systems | <ul style="list-style-type: none">a. Residual heat removal/suppression pool cooling system to remove heat from the suppression pool during accidents, with 2 trains and 4 pumps.b. Residual heat removal/shutdown cooling system to remove decay heat during accidents in which reactor vessel integrity is maintained and reactor at low pressure, with 2 trains and 4 pumps.c. Residual heat removal/containment spray system to suppress pressure and remove decay heat in the containment during accidents, with 2 trains and 4 pumps. |
| 4. Reactivity Control Systems | <ul style="list-style-type: none">a. Control rods.b. Standby liquid control system, with 2 parallel positive displacement pumps rated at 43 gpm per pump, but each with 86 gpm equivalent because of the use of enriched boron. |
| 5. Containment Structure | <ul style="list-style-type: none">a. BWR Mark I.b. 0.32 million cubic feet.c. 56 psig design pressure. |
| 6. Containment Systems | <ul style="list-style-type: none">a. Containment venting—drywell and wetwell vents used when suppression pool cooling and containment sprays have failed to reduce primary containment pressure. |

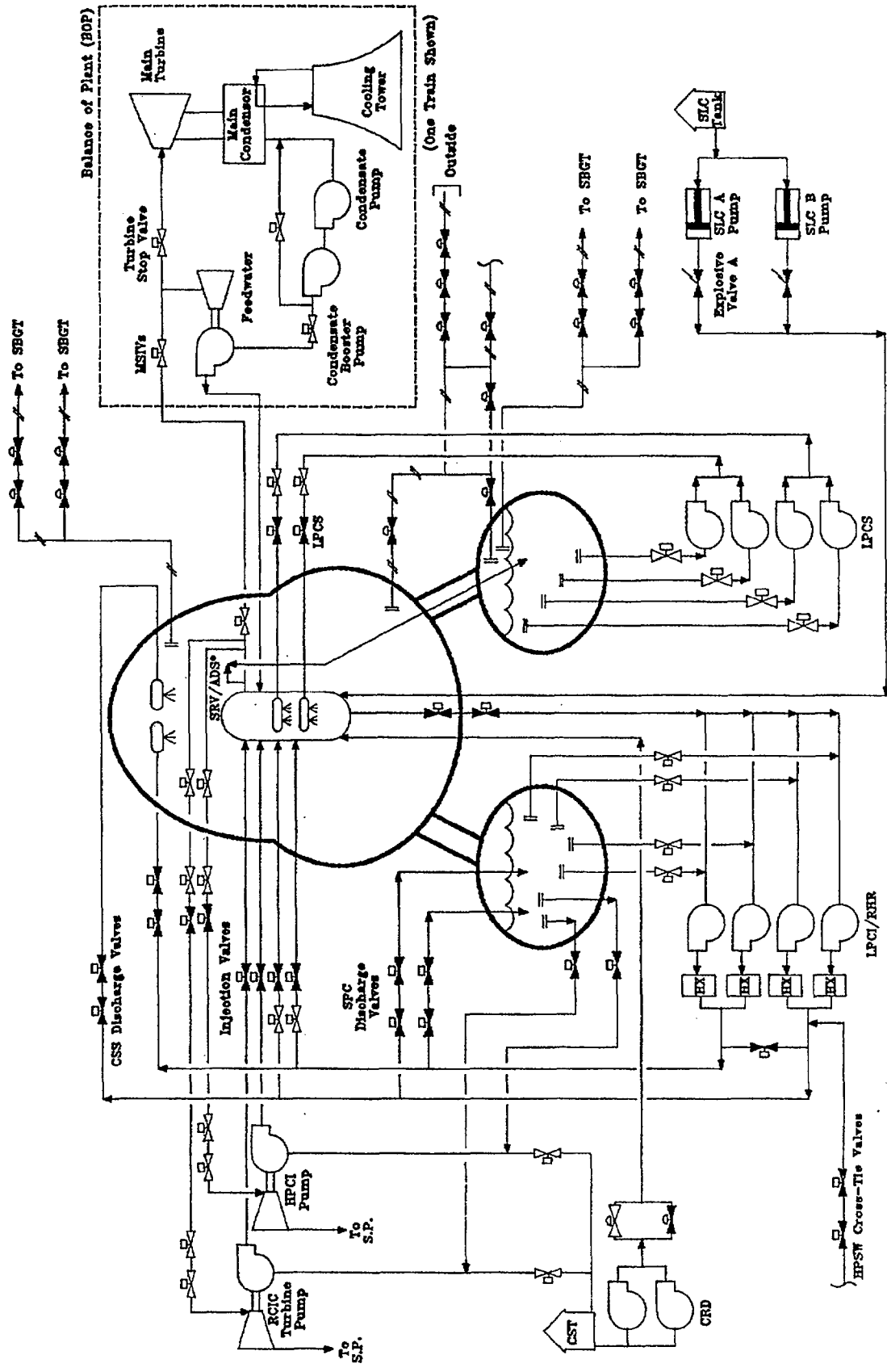

*Typical arrangement (5 ADS SRVs and 6 non-ADS SRVs)

Figure 4.1 Peach Bottom plant schematic.

4. Peach Bottom Plant Results

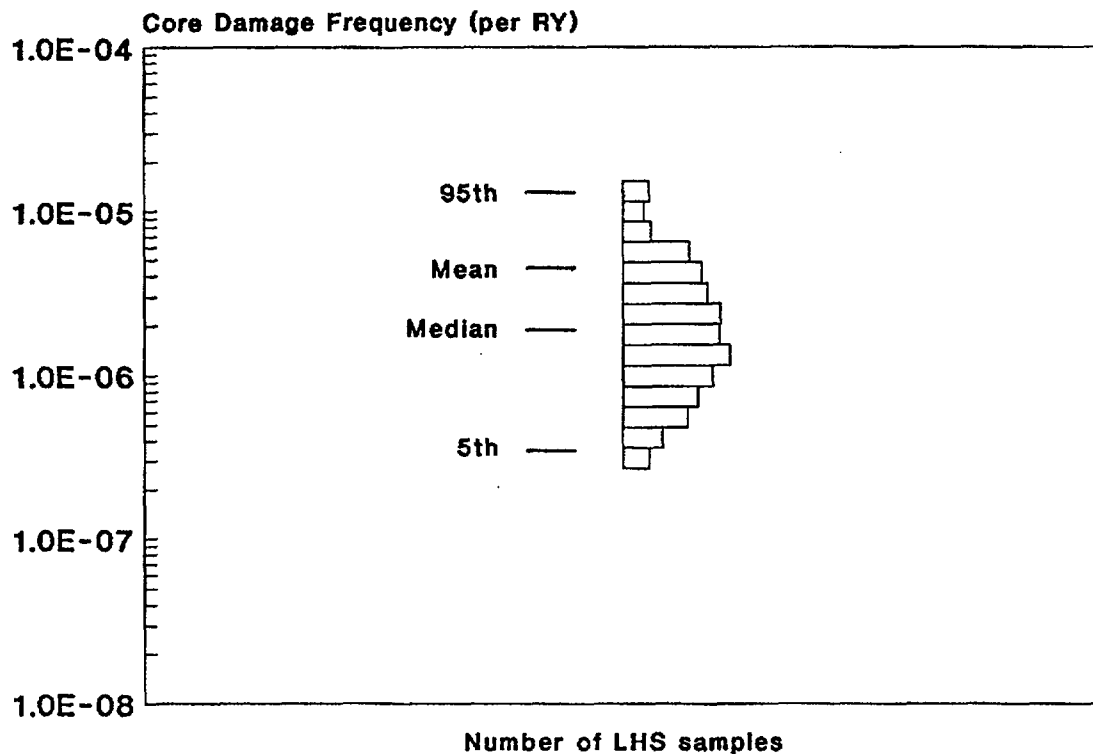

Note: As discussed in Reference 4.4, core damage frequencies below 1E-5 per reactor year should be viewed with caution because of the remaining uncertainties in PRA (e.g., events not considered).

Figure 4.2 Internal core damage frequency results at Peach Bottom.

Table 4.2 Summary of core damage frequency results: Peach Bottom.*

| | 5% | Median | Mean | 95% |
|-------------------|---------|--------|--------|--------|
| Internal Events | 3.5E-7 | 1.9E-6 | 4.5E-6 | 1.3E-5 |
| Station Blackout | 8.3E-8 | 6.2E-7 | 2.2E-6 | 6.0E-6 |
| ATWS | 3.1E-8 | 4.4E-7 | 1.9E-6 | 6.6E-6 |
| LOCA | 2.5E-9 | 4.4E-8 | 2.6E-7 | 7.8E-7 |
| Transient | 6.1E-10 | 1.9E-8 | 1.4E-7 | 4.7E-7 |
| External Events** | | | | |
| Seismic (LLNL) | 5.3E-8 | 4.4E-6 | 7.7E-5 | 2.7E-4 |
| Seismic (EPRI) | 2.3E-8 | 7.1E-7 | 3.1E-6 | 1.3E-5 |
| Fire | 1.1E-6 | 1.2E-5 | 2.0E-5 | 6.4E-5 |

*Note: As discussed in Reference 4.4, core damage frequencies below 1E-5 per reactor year should be viewed with caution because of the remaining uncertainties in PRA (e.g., events not considered).

**See "Externally Initiated Accident Sequences" in Section 4.2.1.2 for discussion.

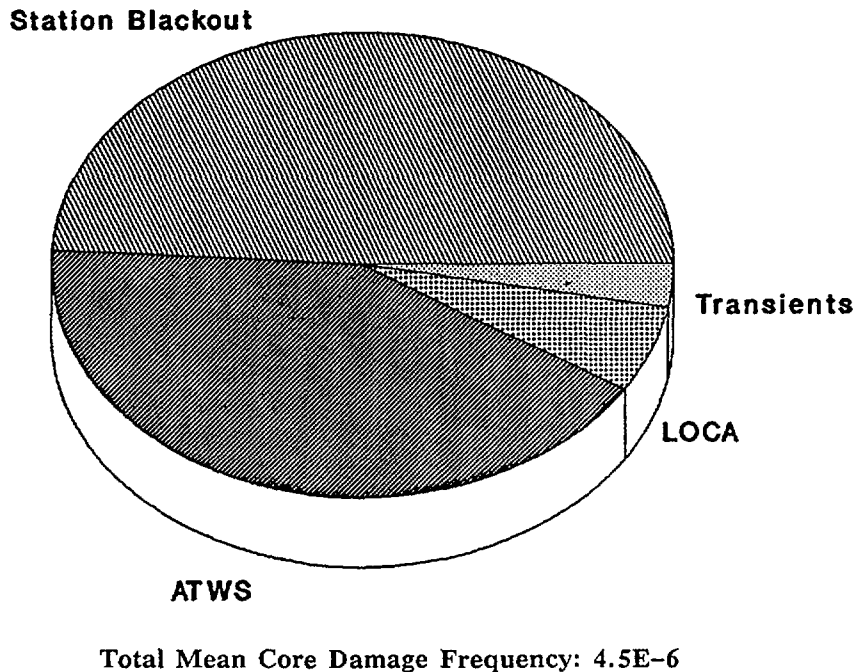

Figure 4.3 Contributors to mean core damage frequency from internal events at Peach Bottom.

but ultimately fail at approximately 10 hours because of battery depletion or other late failure modes (e.g., loss of room cooling effects). Core damage results in 10 to 13 hours as a result of coolant boiloff.

Within the general class of anticipated transient without scram accidents, the more probable combinations of failures leading to core damage are:

- Transient (e.g., loss of feedwater) occurs followed by a failure to trip the reactor because of mechanical faults in the reactor protection system (RPS) and closure of the main steam isolation valves (MSIVs). The standby liquid control system (SLCS) does not function (primarily because of operator failure to actuate), but the HPCI does start. However, increased suppression pool temperatures fail the HPCI. Low-pressure coolant injection (LPCI) is unavailable and all core cooling is lost. Core damage occurs in approximately 20 minutes to several hours, depending on the time at which the LPCI fails because of different LPCI failure modes.
- Transient occurs followed by a failure to scram (mechanical faults in the RPS) and closure of the MSIVs. SLCS is initiated but

HPCI fails to function because of random faults. The operator fails to depressurize after HPCI failure and therefore the low-pressure core cooling systems cannot inject. Core damage occurs in approximately 15 minutes.

Within the general class of LOCAs, the more probable combination of failures leading to core damage is:

- A medium-size LOCA (i.e., break size of approximately 0.004 to 0.1 ft²) occurs. HPCI works initially but fails because of low steam pressure. The low-pressure core cooling systems fail to actuate primarily because of miscalibration faults of the pressure sensors, which do not "permit" the injection valves to open. All core cooling is lost and core damage occurs in approximately 1 to 2 hours following the initiating event.

4.2.1.2 Externally Initiated Accident Sequences

A detailed description of accident sequences initiated by external events important at the Peach Bottom plant is provided in Part 3 of Reference 4.1. The accident sequences described in that reference have been grouped into two main types for this study. These are:

4. Peach Bottom Plant Results

- Seismic, and
- Fire.

A scoping study has also been performed to assess the potential effects of other externally initiated accidents (Ref. 4.1, Part 3). This analysis indicated that the following external-event sources could be excluded based on the low frequency of the initiating event:

- Aircraft crashes,
- Hurricanes,
- Tornados,
- Internal flooding, and
- External flooding.

1. Seismic Accident Frequency Analysis

The relative contribution of classes of seismically and fire-initiated accidents to the total mean frequency of externally initiated core damage accidents is provided in Figure 4.4. As may be seen, the dominant seismic scenarios are transient (38%) and LOCA sequences (27%) with the other contributors being substantially less. For these two seismic accident initiators, the more probable combinations of system failures are:

- The transient sequence results from seismically induced failure of ceramic insulators in the switchyard causing loss of offsite power (LOSP) in conjunction with loss of onsite ac power. This latter results primarily from loss of the emergency service water (ESW) system (which provides the jacket cooling for the emergency diesel generators) and/or direct failures of 4 kV buses or the diesel generators themselves. The vast majority of failures are seismically induced.
- The large LOCA sequence is initiated by postulated seismically induced failures of the supports on the recirculation pumps. Core damage results from this initiator in conjunction with seismically induced failures of the low-pressure injection systems. The latter requires ac power, and the dominant sources of failure of onsite ac power are the ESW or emergency diesel generator seismic failures as discussed above.

As discussed in Chapter 2, the seismic analysis in this report made use of two sets of hazard curves from Lawrence Livermore National Laboratory (LLNL) (Ref. 4.5) and the Electric Power Research Institute (EPRI) (Ref. 4.6). The differ-

ences between the seismic core damage frequencies shown in Table 4.2 for the LLNL and the EPRI cases are due entirely to the differences between the two sets of hazard curves. That is, the system models, failure rates, and success logic were identical for both estimates.

The seismic hazard associated with the curves developed by EPRI was significantly less than that of the LLNL curves. Differences between these curves result primarily from differences between the methodology and assumptions used to develop the hazard curves. In the LLNL program, considerable emphasis was placed on a wide range of uncertainty in the ground-motion attenuation models, while a relatively coarse set of seismic tectonic provinces was used in characterizing each site. By contrast, in the EPRI program considerable emphasis was placed on a fine zonation for the tectonic provinces, and very little uncertainty in the ground-motion attenuation was considered. In any case, it is the difference between the two sets of hazard curves that causes the differences between the numeric estimates in Table 4.2.

2. Fire Accident Frequency Analysis

The fire-initiated accident frequency analyses performed for this report considered the impact of fires beginning in a variety of separate locations within the plant. Those locations found to be most important were:

- Emergency switchgear rooms,
- Control room, and
- Cable-spreading room.

No other plant locations contributed more than $1.0E-8$ per year to the core damage frequency.

Fires in the cable-spreading room are assumed to require manual plant trip and to fail the high-pressure injection and depressurization systems, namely: high pressure core injection (HPCI), reactor core isolation cooling (RCIC), control rod drive (CRD), and automatic depressurization systems (ADS). In each case, the failure occurs because of fire damage to the control cables.

Fires in the emergency switchgear rooms failed offsite power and in some instances portions of the emergency service water system, and core damage occurs because of a station blackout sequence involving additional random failures of the emergency service water system (which provides jacket cooling to the diesel generators).

Finally, two fire scenarios were identified for the control room, both of which involve manual plant trip and abandonment of the control room. One scenario involved random failure of the RCIC system and a reasonable probability that the operators fail to recover the plant using HPCI or ADS in conjunction with LPCI from the remote shutdown panel. The other scenario failed the RCIC system because of a fire in its control cabinet but

allowed for recovery from the remote shutdown panel.

4.2.2 Important Plant Characteristics (Core Damage Frequency)

Characteristics of the Peach Bottom plant design and operation that have been found to be important in the analysis of core damage frequency include:

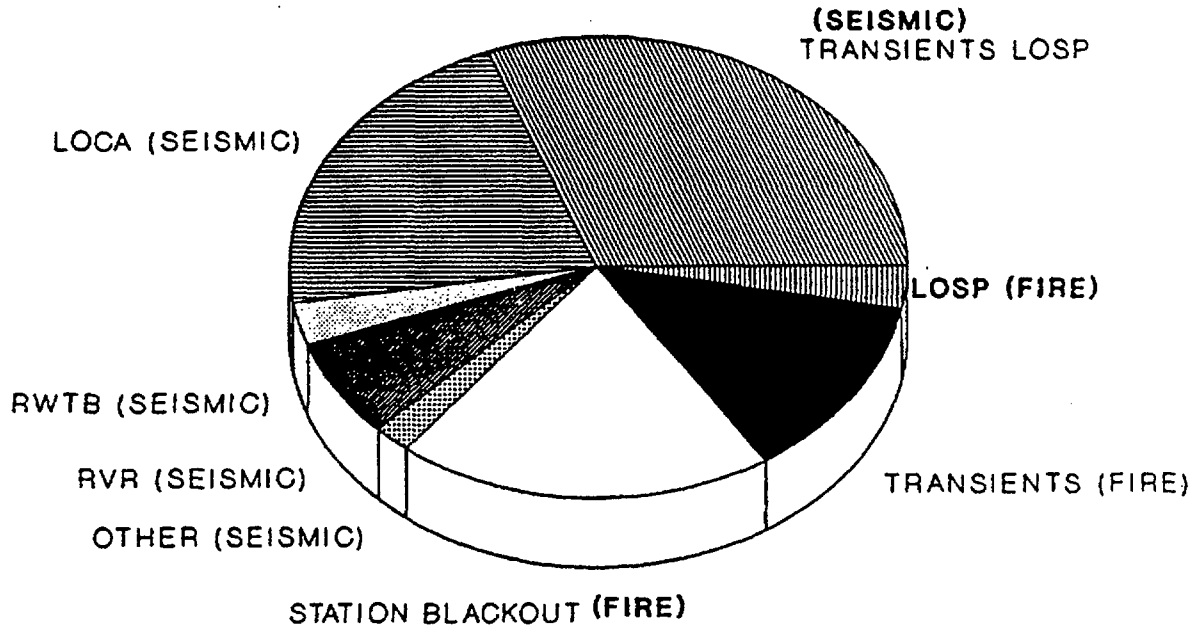

Total Mean Core Damage Frequency: $9.7E-5$

Figure 4.4 Contributors to mean core damage frequency from external events (LLNL hazard curve) at Peach Bottom.

1. High-Pressure Service Water System Crosstie

The high-pressure service water (HPSW) system, if the reactor vessel has been depressurized, can inject raw water to the reactor vessel via the residual heat removal injection lines. Most components of HPSW are located outside the reactor building and thus are not affected by any potential severe reactor building environment that could cause other injection systems to fail in some accidents. Therefore, this system offers diversity, as well as redundancy, and affects many dif-

ferent types of sequences. The Peach Bottom operators are trained to use this system and can do so from the control room. An extensive cleanup program would, however, be required after the system is initiated.

2. Redundancy and Diversity of Water Supply Systems

At Peach Bottom, there are many redundant and diverse systems to provide water to the reactor vessel. They include:

4. Peach Bottom Plant Results

High-pressure core injection (HPCI) with 1 pump;

Reactor core isolation cooling (RCIC) with 1 pump;

Control rod drive (CRD) with 2 pumps (both pumps required);

Low-pressure core spray (LPCS) with 4 pumps;

Low-pressure core injection (LPCI) with 4 pumps;

Condensate with 3 pumps; and

High-pressure service water (HPSW) with 4 pumps.

Because of this redundancy of systems, LOCAs and transients other than station blackout and ATWS are small contributors to the core damage frequency.

CRD, condensate, and HPSW pumps are located outside the reactor building (generally away from potentially severe environments) and represent excellent secondary high- and low-pressure coolant systems if normal injection systems fail. These systems are not available during station blackout.

3. Redundancy and Diversity of Heat Removal Systems

At Peach Bottom, there are several diverse means for heat removal. These systems are:

Main steam/feedwater system;

Suppression pool cooling mode of residual heat removal (RHR);

Shutdown cooling mode of RHR;

Containment spray system mode of RHR; and

Containment venting.

This diversity has greatly reduced the importance of transients with long-term loss of heat removal.

4. Diesel Generators

Peach Bottom is a two-unit site with four emergency diesels shared between the two units. One diesel can supply the necessary power for both units. DC power to start the diesels is supplied from vital dc station batteries. The four emergency diesels share a common service water system that provides oil cooling, jacket, and air cooling. The Peach Bottom emergency diesels historically have

had a failure-to-start probability that is much better than the industry average, e.g., a factor of ~ 10 lower failure probability.

5. Battery Capacity

Philadelphia Electric Company (PECo) has performed analyses of the battery life based on the current station blackout procedures. PECO estimates that the station batteries at Peach Bottom are capable of lasting at least 12 hours in a station blackout. They have revised their station blackout procedure to include load shedding in order to ensure a longer period of injection and accident monitoring. The ability to ensure availability for 12 hours reduces the frequency of core damage resulting from station blackout accident sequences.

6. Emergency Service Water (ESW) System

The ESW system provides cooling water to selected equipment during a loss of offsite power. The system has two full capacity self-cooled pumps whose suction is from the Conowingo pond and a backup third pump with a separate water source. Failure of the ESW system would quickly fail operating diesel generators and potentially fail the low-pressure core spray (LPCS) pumps and the RHR pumps. The HPCI pumps and RCIC pumps would fail (in the long term) from a loss of their room cooling after a loss of the ESW system.

It should be noted that there is an outstanding issue regarding the need for ESW that involves whether or not the LPCS/RHR pumps actually require ESW cooling. PECO has stated that these pumps are designed to operate with working fluid temperatures approaching 160°F without pump cooling. This implies that in scenarios where the ESW system has been lost, these pumps could still operate; some RHR pumps would be placed in the suppression pool cooling mode and therefore keep the working fluid at less than 160°F. It is felt that there is significant validity to these arguments. However, because it is uncertain whether the suppression pool water can be maintained below 160°F in some sequences and whether PECO has properly accounted for pump heat addition to the system, the analysis summarized here assumes these LPCS/RHR pumps will fail upon loss of ESW cooling.

7. Automatic and Manual Depressurization System

The automatic depressurization system (ADS) is designed to depressurize the reactor vessel to a pressure at which the low-pressure injection systems can inject coolant. The ADS consists of five safety relief valves capable of being manually opened. The operator may manually initiate the ADS or may depressurize the reactor vessel, using the six additional relief valves that are not connected to the ADS logic. The ADS valves are located inside the containment; however, the instrument nitrogen and the dc power required to operate the valves are supplied from outside the containment.

8. Standby Liquid Control (SLC) System

The SLC system provides a backup method that is redundant but independent of the control rods to establish and maintain the reactor subcritical. The suction for the SLC system comes from a control tank that has sodium pentaborate in solution with demineralized water. Most of the SLC system is located in the reactor building outside the drywell. Local access to the SLC system could be affected by containment failure or containment venting.

9. Venting Capability

The primary containment venting system at Peach Bottom is used to prevent containment pressure limits from being exceeded. There are several vent paths:

- 2-inch torus vent to standby gas treatment (SBGT),
- 6-inch integrated leak rate test (ILRT) pipe from the torus,
- 18-inch torus vent path,
- 18-inch torus supply path,
- 2-inch drywell vent to SBGT,
- Two 3-inch drywell sump drain lines,
- 6-inch ILRT line from drywell,
- 18-inch drywell vent path, and
- 18-inch drywell supply path.

The types of sequences on which venting has the most effect are transients with long-term loss of decay heat removal. The chance of survival of the containment is increased with venting; therefore, the core damage frequency from such sequences is reduced.

If the reactor is at decay heat loads, venting using the 6-inch ILRT line or equivalent as a minimum is sufficient to lessen the containment pressure. However, in an ATWS sequence, three to four of the large 18-inch vent pathways need to be used in order to achieve the same effect. It is preferable to use a vent pathway from the torus rather than from the drywell because of the scrubbing of radioactive material coming through the suppression pool.

It is significant to note that the 6-inch ILRT line is a solid pipe rather than ductwork, so that venting by means of this pipe does not create a severe environment within the reactor building; use of the 18-inch lines will result in failure of the ductwork and severe environments within the reactor building.

10. Location of Control Rod Drive (CRD) Pumps

The CRD pumps at Peach Bottom are not located in the reactor building (like most plants) but are in the turbine building. Therefore, in a severe accident where severe environments are sometimes created, the CRD pumps are not subjected to these environments and can continue to operate.

4.2.3 Important Operator Actions

The emergency operating procedures (EOPs) at Peach Bottom direct the operator to perform certain actions depending on the plant conditions or symptoms (e.g., reactor vessel level below top of active fuel). Different accident sequences can have similar symptoms and therefore the same "recovery" actions. The operator actions that either are important in reducing accident frequencies or are contributing to accident frequencies are discussed and can apply to many different accident sequences.

The quantification of these human failure events was based on an abbreviated version of the THERP method (Ref. 4.7). These failure events include the following:

- Actuate core cooling

In an accident where feedwater is lost (which includes condensate), the reactor vessel water level starts to decrease. When Level 2 is reached, HPCI and RCIC should be automatically actuated. If Level 1 is reached, the automatic depressurization system (ADS) should be actuated with automatic actuation

4. Peach Bottom Plant Results

of the low-pressure core spray (LPCS) and low-pressure coolant injection (LPCI). If these systems fail to actuate, the operator can attempt to manually actuate them from the control room. In addition, the operator can attempt to recover the power conversion system (PCS) (i.e., feedwater) or manually initiate control rod drive (CRD) (i.e., put CRD in its enhanced flow mode). If automatic depressurization failure was one of the faults, the operator can manually depressurize so that LPCS and LPCI can inject. Lastly, the operator also has the option to align the HPSW to LPCI for another core cooling system.

- Establish containment heat removal

Besides core cooling, the operator must also establish containment heat removal (CHR). Without CHR, the potential exists for operating core cooling systems to fail. If an accident occurs, the EOPs direct the operator to initiate the suppression pool cooling mode of residual heat removal (RHR) after the suppression pool temperature reaches 95°F. The operator closes the LPCI injection valves and the heat exchanger bypass valves and opens the suppression pool discharge valves. He also ensures that the proper service water system train is operating. With suppression pool cooling (SPC) functioning, CHR is being performed. If system faults preclude the use of SPC, the operator has other means to provide CHR. He can actuate other modes of RHR such as shutdown cooling or containment spray; or the operator can vent the containment to remove the heat.

- Restore service water

Many of the components/systems require cooling water from the emergency service water (ESW) system in order to function. If the ESW pumps fail, the operator can manually start the emergency cooling water pump, which is a backup to the ESW pumps.

Specifically for station blackout, there are certain actions that can be performed by the operating crew:

- Recovering ac power

Station blackout is caused by the loss of all ac power, i.e., both offsite and onsite power. Restoring offsite power or repairing the diesel generators was included in the analysis. The

quantification of these human failure events was derived from historical data (i.e., actual time required to perform these repairs) and not by performing a human reliability analysis on these events.

Transients where reactor trip does not occur (i.e., ATWS) involve accident sequences where the phenomena are more complex. The operator actions were evaluated in more detail (using the SLIM-MAUD* method performed by Brookhaven National Laboratory (Ref. 4.8)) than for the regular transients. These actions include the following:

- Manual scram

A transient that demands the reactor to be tripped occurs, but the reactor protection system (RPS) fails from electrical faults. The operator can then manually trip the reactor by first rotating the collar on the proper scram buttons and then depressing the buttons, or he can put the reactor mode switch in the "shutdown" position.

- Insert rods manually

If the electrical faults fail both the RPS and the manual trip, the operator can manually insert the control rods one at a time.

- Actuate standby liquid control (SLC)

With the reactor not tripped, reactor power remains high; the reactor core is not at decay heat levels. This can present problems since the CHR systems are only designed to decay heat removal capacity. However, the SLC system (manually activated) injects sodium pentaborate that reduces reactor power to decay heat levels. The EOPs direct the operator to actuate SLC if the reactor power is above 3 percent and before the suppression pool temperature reaches 110°F. The operator obtains the SLC keys (one per pump) and inserts the keys into the switches and turns only one to the "on" position.

- Inhibit automatic depressurization system (ADS)

In an ATWS condition, the operator is directed to inhibit the ADS if he has actuated SLC. The operator must put both ADS switches in the inhibit mode.

*SLIM-MAUD is a computer algorithm for transforming man-man and man-machine information into probability statements.

- Manually depressurize reactor

If the high-pressure coolant injection (HPCI) fails, inadequate high-pressure core cooling occurs. Because the ADS was inhibited, when Level 1 is reached, ADS will not occur and the operator must manually depressurize so that low-pressure core cooling can inject.

4.2.4 Important Individual Events and Uncertainties (Core Damage Frequency)

As discussed in Chapter 2, the process of developing a probabilistic model of a nuclear power plant involves the combination of many individual events (initiators, hardware failures, operator errors, etc.) into accident sequences and eventually into an estimate of the total frequency of core damage. After development, such a model can also be used to assess the relative importance and contribution of the individual events. The detailed studies underlying this report have been analyzed using several event importance measures. The results of the analyses using two measures, "risk reduction" and "uncertainty" importance, are summarized below.

- Risk (core damage frequency) reduction importance measure (internal events)

The risk-reduction importance measure is used to assess the change in core damage frequency as a result of setting the probability of an individual event to zero. Using this measure, the following individual events were found to cause the greatest reduction in core damage frequency if their probabilities were set to zero:

- Mechanical failure of the reactor protection system. The core damage frequency would be reduced by approximately 52 percent.
- Transient initiators with the power conversion system available. The core damage frequency would be reduced by approximately 47 percent.
- Loss of offsite power initiating event. The core damage frequency would be reduced by approximately 39 percent.
- Operator failure to restore the standby liquid control system after testing. The core damage frequency would be reduced by approximately 25 percent.

- Operator failure to initiate emergency heat sink. The core damage frequency would be reduced by approximately 17 percent.
- Operator failure to actuate standby liquid control system. The core damage frequency would be reduced by approximately 16 percent.
- Operator miscalibrates reactor pressure sensors. The core damage frequency would be reduced by approximately 12 percent.

Note that the top risk-reduction events do not necessarily appear in the most frequent sequences since the latter sequences may result from the cumulative influence of many lesser contributors.

- Uncertainty importance measure (internal events)

A second importance measure used to evaluate the core damage frequency analysis results is the uncertainty importance measure. For this measure, the relative contribution of the uncertainty of individual events to the uncertainty in total core damage frequency is calculated. Using this measure, the following events were found to be most important:

- Mechanical failure of the reactor protection system.
- Failure of the diesel generators to continue to run once started.
- Loss of offsite power or transients with the power conversion system available.
- Miscalibration of the reactor pressure sensors by the operator.
- Operator failure to restore the standby liquid control system after testing.

4.3 Containment Performance Analysis

4.3.1 Results of Containment Performance Analysis

The Peach Bottom Mark I containment design concept consists of a pressure-suppression containment system that houses the reactor vessel, the reactor coolant recirculating loops, and other branch connections to the reactor coolant system. The containment design consists of a light-bulb-shaped drywell and a water-filled toroidal-shaped suppression pool. Both the drywell and the suppression pool are freestanding steel shells with the drywell region backed by a reinforced concrete structure. The containment system has a volume

4. Peach Bottom Plant Results

of 320,000 cubic feet and is designed to withstand a peak pressure of 56 psig resulting from a primary system loss-of-coolant accident. The estimated mean failure pressure for Peach Bottom's containment system is 148 psig, which is very similar to that for large PWR containment designs. However, its small free volume relative to other containment types significantly limits its capacity to accommodate noncondensable gases generated in severe accident scenarios in addition to increasing its potential to come into contact with molten core material. The complexity of the events occurring in severe accidents has made predictions of when and where Peach Bottom's containment would fail heavily reliant on the use of expert judgment to interpret and supplement the limited data available.

The potential for early containment failure (before or within roughly 2 hours after reactor vessel breach) is of principal concern in Peach Bottom's risk analysis. For the Peach Bottom Mark I type of containment, the principal mechanisms that can cause its early failure are (1) drywell shell meltthrough due to its interaction with the molten core material released from the breached reactor pressure vessel, (2) overpressure failure of the drywell due to rapid direct containment heating following reactor vessel breach, and (3) stretching of the drywell head bolts (due to internal pressurization) causing a direct leakage path from the system. Possible overpressure failures due to hydrogen combustion effects are of negligible probability for Peach Bottom since the containment is inerted. In addition to the early modes of containment failure, core damage sequences can also result in late containment failure or no containment failure at all.

The results of the Peach Bottom containment analysis are summarized in Figures 4.5 and 4.6. Figure 4.5 contains a display of information in which the conditional probabilities of 10 containment-related accident progression bins; e.g., V.B-early WWF - >200, are presented for each of six plant damage states, such as station blackout. This information indicates that, on a plant damage state frequency-weighted average,* the mean conditional probability from internally initiated accidents of: (1) early wetwell failure is about 0.03, (2) early drywell failure is about 0.52, (3) late failure of either the wetwell or drywell is about 0.04, and (4) no containment failure is about

*Each value in the column in Figure 4.5 labeled "All" is obtained by summing the products of individual accident progression bin conditional probabilities for each plant damage state and the ratio of the frequency of that plant damage state to the total core damage frequency.

0.27. Figure 4.6 further displays the conditional probability distribution of early containment failure for each plant damage state, thereby providing the estimated range of uncertainties in these containment failure predictions. The important conclusions that can be drawn from the information in these two figures are: (1) there is a high mean probability (i.e., 50%) that the Peach Bottom containment will fail early for the dominant plant damage states; (2) early containment failures will primarily occur in the drywell structure resulting in a bypass of the suppression pool's scrubbing effects for radioactive material released after vessel breach; and (3) the principal cause of early drywell failure is drywell shell meltthrough. The data further indicate that the early containment failure probability distributions for most plant damage states are quite broad. Also presented in these displays of containment failure information is evidence that there is a high probability of early containment failure during external events such as fire and earthquakes. Specifically, the seismic analysis indicates that the conditional probability of early containment failure from all causes, i.e., direct containment structural failure or related failure from the effects of a core damage event, could be as high as 0.9.

Additional discussion on containment performance (for all studied plants) is provided in Chapter 9.

4.3.2 Important Plant Characteristics (Containment Performance)

Characteristics of the Peach Bottom containment design and operation that are important during core damage accidents include:

1. Containment Inerting

The Peach Bottom containment is maintained in an inerted state, i.e., nitrogen filled. This inerted containment condition significantly reduces the chance of hydrogen combustion in the containment, thereby removing a major threat to its failure. However, hydrogen combustion in the reactor building is a possibility for some severe accident sequences.

2. Drywell Sprays

The Peach Bottom drywell contains a spray header that can be used to mitigate the effects of the actions of molten core material on the floor of the drywell. In particular, the spray system may provide sufficient water to prevent the molten core material from coming into contact with the drywell shell and potentially causing its failure.

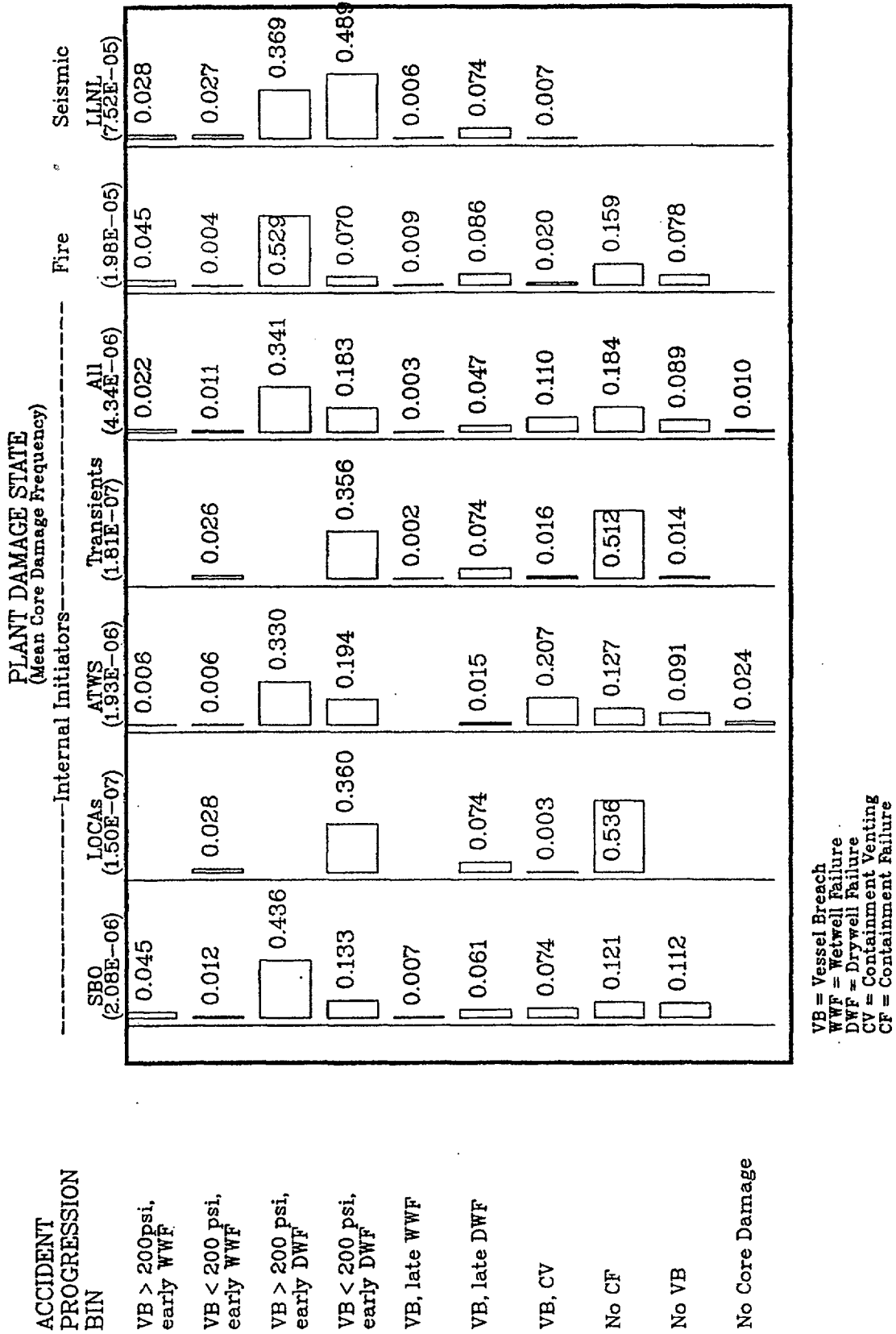

Figure 4.5 Conditional probability of accident progression bins at Peach Bottom.

4. Peach Bottom Plant Results

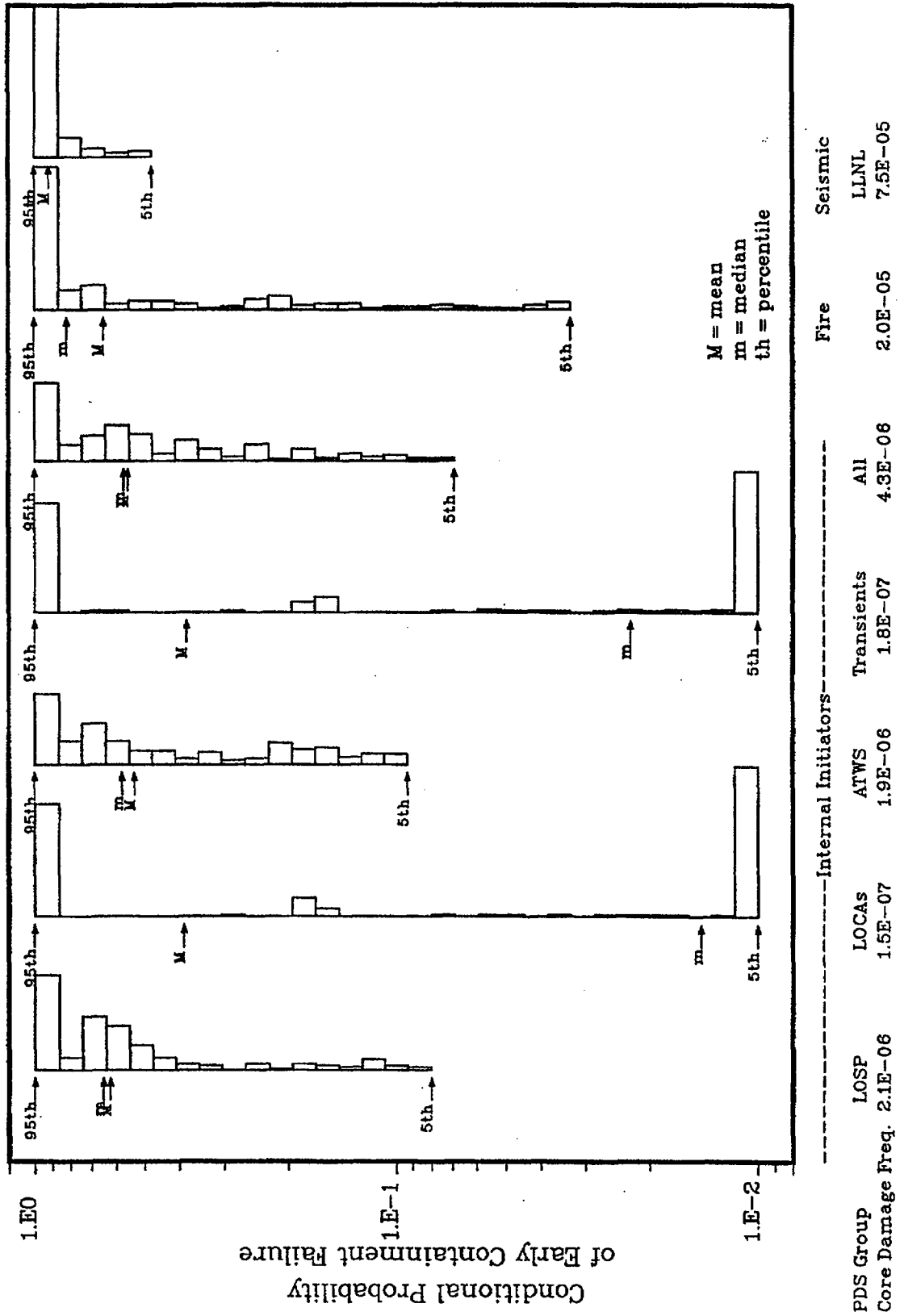

Figure 4.6 Conditional probability distributions for early containment failure at Peach Bottom.

4.4 Source Term Analysis

4.4.1 Results of Source Term Analysis

Failure of the drywell shell following vessel meltthrough is a characteristic of the risk-dominant accident progression bins for the Peach Bottom plant. Figure 4.7 illustrates the source terms for the early failure accident progression bin in which the reactor coolant system is pressurized (> 200 psi) at the time of vessel failure. In comparison with the bypass release that was illustrated for Surry in Figure 3.7, the core fractions of the volatile groups (iodine, cesium, and tellurium) released to the environment are slightly reduced. For the majority of accident sequences in Peach Bottom, the radionuclides released from fuel in-vessel must pass through the suppression pool where substantial decontamination is possible. In sequences where the drywell spray system is operable, the ex-vessel release will also be mitigated by the spray or an overlaying pool of water. Both the in-vessel and ex-vessel releases will receive further attenuation in the reactor building before release to the environment. Even if the decontamination factor of some of these stages is small, the overall effect is to make the likelihood of a very large release quite small.

The Peach Bottom plant has instituted emergency operating procedures to vent the containment in the wetwell region to avoid failure by overpressurization. Figure 4.8 shows the source terms for the accident progression bin in which the containment is vented and no subsequent failure of the containment occurs. The source terms for the volatile radionuclide groups are less than those for the early drywell failure bin discussed previously. In both cases, scrubbing of the in-vessel release by the suppression pool has the principal mitigating influence on the environmental release. The release fractions for the less volatile groups are smaller for the vented accident progression bin but only by approximately a factor of one-half. There are two reasons why the differences between the environmental release of the ex-vessel species for the vented and drywell failure cases are not greater. The decontamination capability of the suppression pool for ex-vessel release, in which the flow is through the downcomers, is somewhat less than for the in-vessel release, which passes through spargers on the safety relief lines. Thus, even though the ex-vessel release must pass through the pool for the vented case, the decontamination factor may be small. The ex-vessel release for the drywell failure accident progression bin will at least be subjected to decontamination

in the reactor building and possibly to sprays and scrubbing by an overlaying water layer.

The range of uncertainty in the release for the barium and strontium radionuclide groups is particularly evident. The spread between the mean and median is two orders of magnitude. Although the release is likely to be quite small, the mean value of the release is as high as the mean value for the tellurium release.

Additional discussion on source term perspectives is provided in Chapter 10.

4.4.2 Important Plant Characteristics (Source Term)

1. Reactor Building

The Peach Bottom containment is located within a reactor building. A release of radioactive material to the reactor building will undergo some degree of decontamination before release to the environment. An important consideration in determining the magnitude of building decontamination is whether hydrogen combustion occurs in the building and whether combustion is sufficiently energetic to fail the building. The range of decontamination factors for the reactor building used in the study is from 1.1 to 10 with a median value of 3 for typical accident conditions.

2. Pressure-Suppression Pool

The pressure-suppression pool is particularly effective in the reduction of the in-vessel release component of the source terms for Peach Bottom. The range of decontamination factors used is from 1.2 to 4000 with a median of 80 for flow through the safety relief valve lines.

The submergence is less and bubble size is larger for flow through the downcomers than for the spargers through which the in-vessel release is most likely to enter the pool. As a result, the decontamination factor for the ex-vessel release or any in-vessel release that passes through the drywell is smaller, ranging from approximately 1 to 90 with a median of 10. Furthermore, the likelihood of failure of the drywell at the time of vessel meltthrough is predicted to be high. For scenarios involving early drywell failure, the suppression pool would be bypassed during the period of core-concrete interaction and radionuclide release.

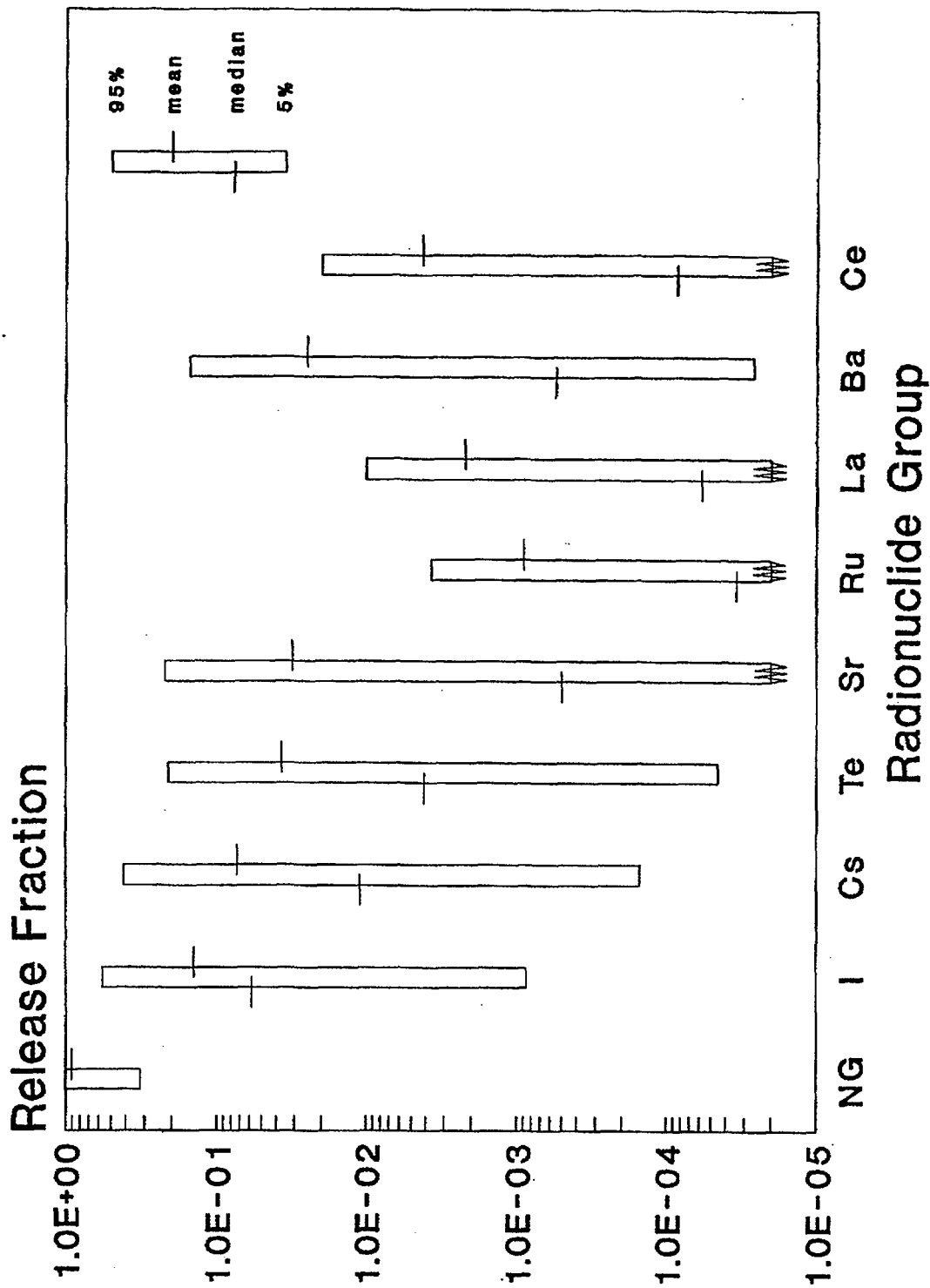

Figure 4.7 Source term distributions for early failure in drywell at Peach Bottom.

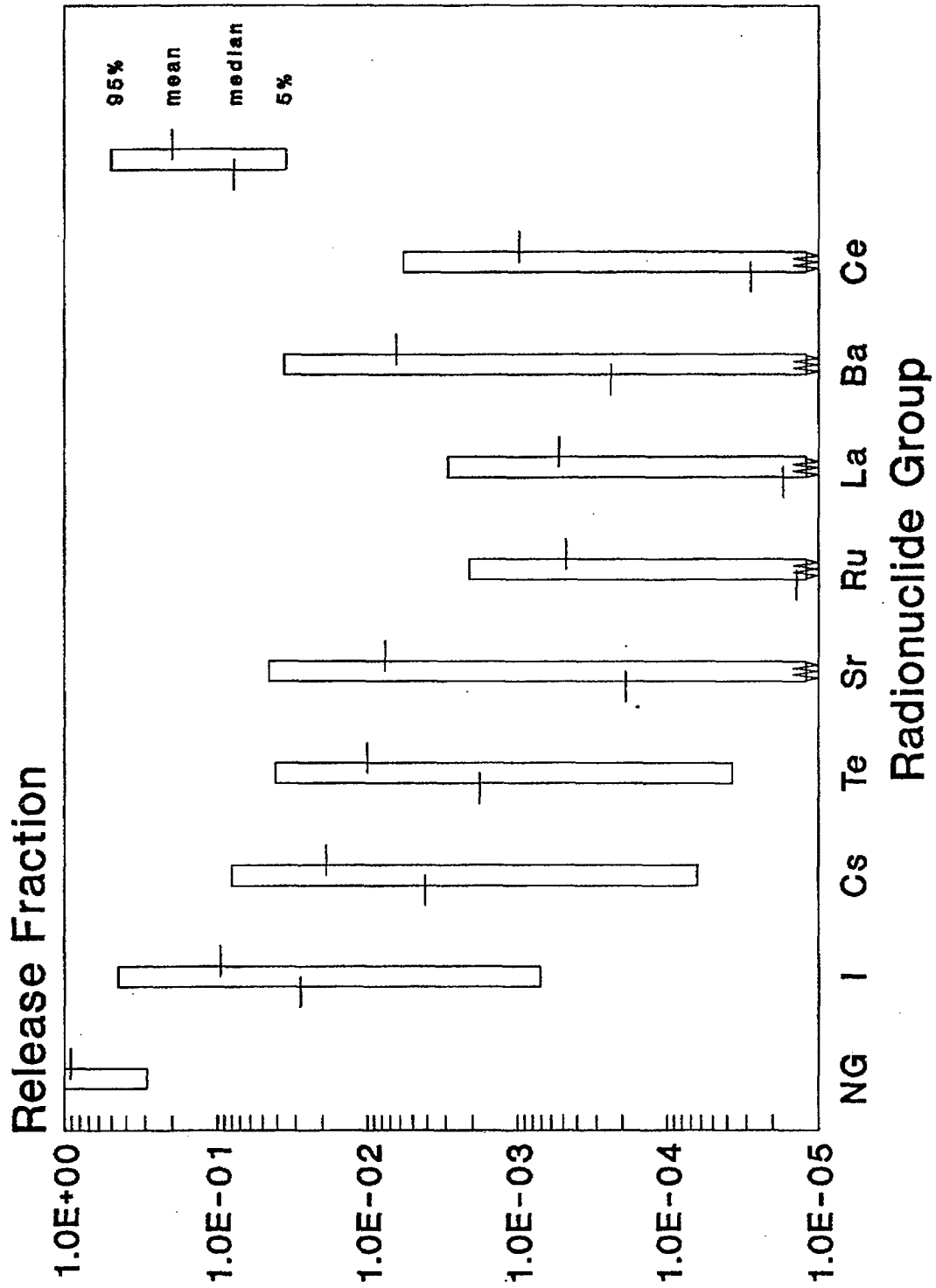

Figure 4.8 Source term distributions for vented containment at Peach Bottom.

4. Peach Bottom Plant Results

3. Venting

The Peach Bottom containment can be vented from the wetwell air space. By preventing containment failure, venting can potentially prevent some scenarios from becoming core damage accidents. In scenarios that proceed to fuel melting, venting can lead to the mitigation of the release of radioactive material to the environment by ensuring that the release passes through the suppression pool. The effect of venting on core damage frequency is described in Chapter 8. Figure 4.8 illustrates the source term characteristics for the venting accident progression bins. Although the source terms are somewhat less than for the early drywell failure accident progression bin, the uncertainties in the release fractions are quite broad. At the high end of the uncertainty range, it is possible that 40 percent of the core inventory of iodine could be released to the environment.

The effectiveness of venting to mitigate severe accident release of radioactive material is limited in the Peach Bottom analyses because of the high likelihood of early drywell failure, particularly as the result of direct attack of the shell by molten core debris. If direct attack of the containment shell is determined not to lead to failure or if effective means are found to preclude failure, the effectiveness of venting could be greater. However, considering the range of uncertainties in the source term analyses, the predicted consequences of vented accident progression bins are not necessarily minor.

4.5 Offsite Consequence Results

Figures 4.9 and 4.10 display the frequency distributions in the form of graphical plots of the complementary cumulative distribution functions (CCDFs) of four offsite consequence measures—early fatalities, latent cancer fatalities, and the 50-mile and entire site region population exposures (in person-rems). The CCDFs in Figures 4.9 and 4.10 include contributions from all source terms associated with reactor accidents caused by the internal initiating events and fire, respectively. Four CCDFs, namely, the 5th percentile, 50th percentile (median), 95th percentile, and the mean CCDFs, are shown for each consequence measure.

Peach Bottom plant-specific and site-specific parameters were used in the consequence analysis for these CCDFs. The plant-specific parameters

included source terms and their frequencies, the licensed thermal power (3293 MWt) of the reactor, and the approximate physical dimensions of the power plant building complex. The site-specific parameters included exclusion area radius (820 meters), meteorological data for 1 full year collected at the site meteorological tower, the site region population distribution based on the 1980 census data, topography (fraction of the area that is land—the remaining fraction is assumed to be water), land use, agricultural practice and productivity, and other economic data for up to 1,000 miles from the Peach Bottom plant.

The consequence estimates displayed in these figures have incorporated the benefits of the following protective measures: (1) evacuation of 99.5 percent of the population within the 10-mile plume exposure pathway emergency planning zone (EPZ), (2) early relocation of the remaining population only from the heavily contaminated areas both within and outside the 10-mile EPZ, and (3) decontamination, temporary interdiction, or condemnation of land, property, and foods contaminated above acceptable levels.

The population density within the Peach Bottom 10-mile EPZ is about 90 persons per square mile. The average delay time before evacuation (after a warning prior to radionuclide release) from the 10-mile EPZ and average effective evacuation speed used in the analyses were derived from information contained in a utility-sponsored Peach Bottom evacuation time estimate study (Ref. 4.9) and the NRC requirements for emergency planning.

The results displayed in Figures 4.9 and 4.10 are discussed in Chapter 11.

4.6 Public Risk Estimates

4.6.1 Results of Public Risk Estimates

A detailed description of the results of the Peach Bottom risk is provided in Reference 4.2. For this summary report, results are provided for the following measures of public risk:

- Early fatality risk,
- Latent cancer fatality risk,
- Population dose within 50 miles of the site,
- Population dose within the entire site region,
- Individual early fatality risk in the population within 1 mile of the Peach Bottom exclusion area boundary, and
- Individual latent cancer fatality risk in the population within 10 miles of the site.

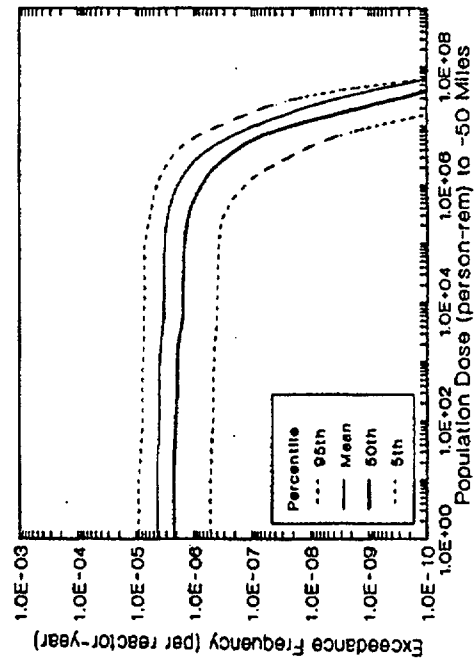
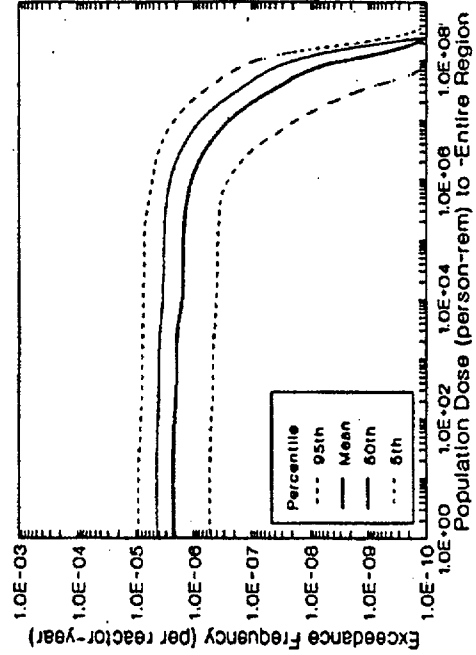
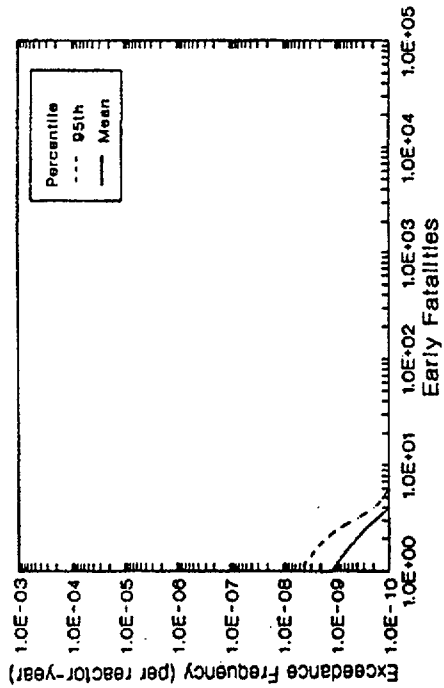
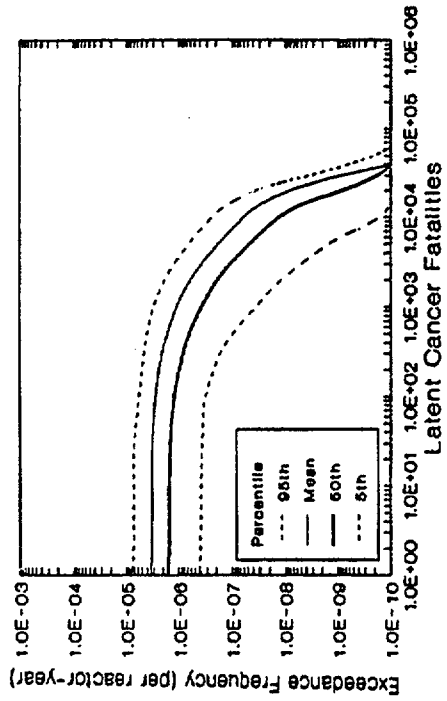

Note: As discussed in Reference 4.4, estimated risks at or below 1E-7 per reactor year should be viewed with caution because of the potential impact of events not studied in the risk analyses.

Figure 4.9 Frequency distributions of offsite consequence measures at Peach Bottom (internal initiators).

4. Peach Bottom Plant Results

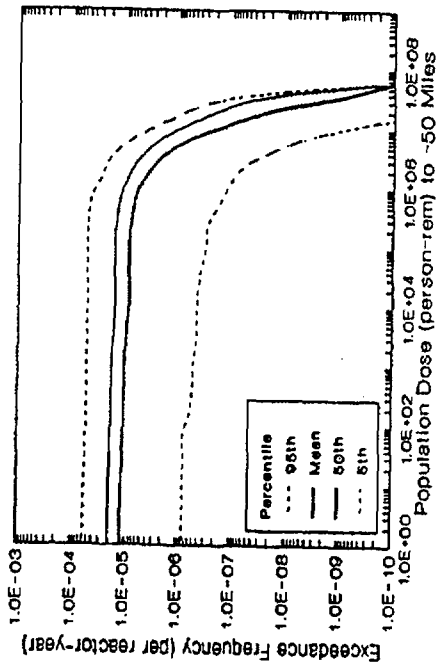
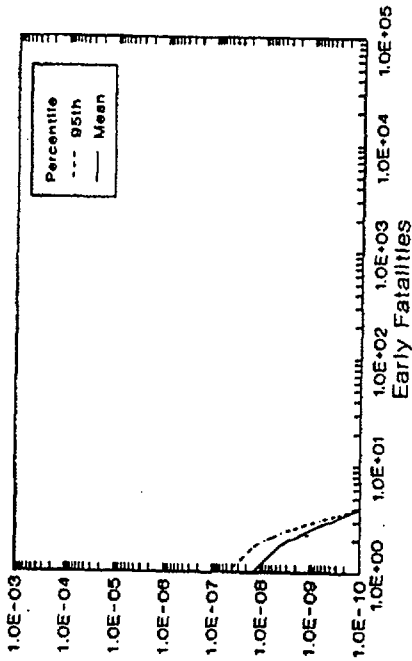
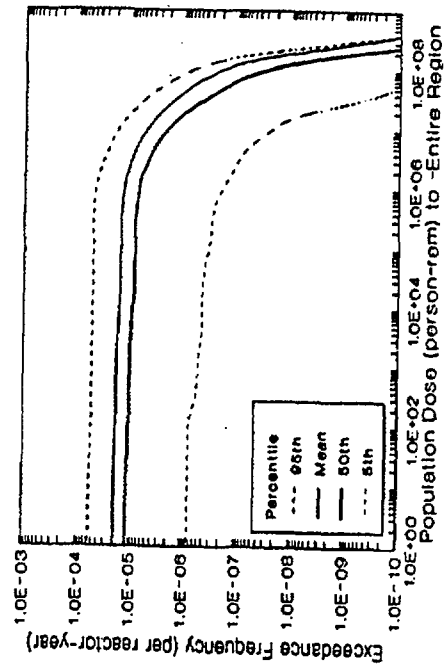
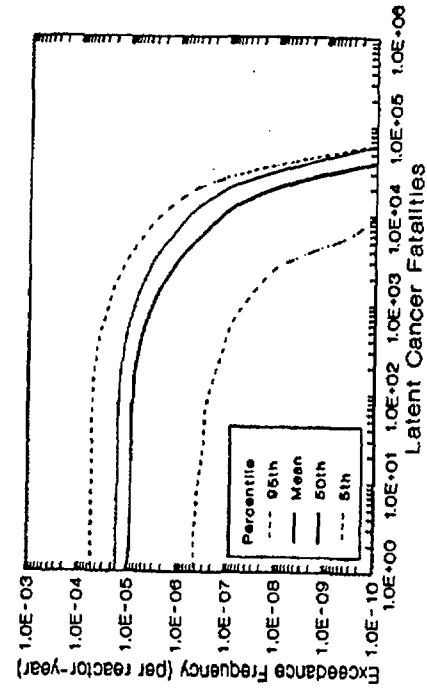

Note: As discussed in Reference 4.4, estimated risks at or below $1E-7$ per reactor year should be viewed with caution because of the potential impact of events not studied in the risk analyses.

Figure 4.10 Frequency distributions of offsite consequence measures at Peach Bottom (fire initiators).

The first four of the above measures are commonly used measures in nuclear power plant risk studies. The last two are those used to compare with the NRC safety goals (Ref. 4.10).

4.6.1.1 Internally Initiated Accident Sequences

The results of the risk studies using the above measures are shown in Figures 4.11 through 4.13. The figures display the variabilities in mean risks estimated from the meteorology-averaged conditional mean values of the consequence measures. For the first two measures, the results of the first risk study of Peach Bottom, the Reactor Safety Study (Ref. 4.3), are also provided. As may be seen, the early fatality risk from Peach Bottom is estimated to be very low. Latent cancer fatality risks are lower than those of the Reactor Safety Study. The risks of population dose and individual early fatality risk are also very low, and the individual latent cancer fatality risk is orders of magnitude lower than the NRC safety goals. These comparisons are discussed in more detail in Chapter 12.

The risk results shown in Figure 4.11 have been analyzed to determine the relative contributions of plant damage states and accident progression bins to mean risk. The results of this analysis are provided in Figures 4.14 and 4.15. As can be seen from these figures, and from the supporting document (Ref. 4.2), the major contributors to both early and latent cancer fatality risks are from station blackout (SBO) and anticipated transients without scram (ATWS). The dominant accident progression bins are early containment failure and drywell failure caused by drywell meltthrough and loads at vessel breach (due to direct containment heating, steam blowdown, or quasistatic pressure from steam explosion).

4.6.1.2 Externally Initiated Accident Sequences

As discussed in Section 4.2.1.2, the Peach Bottom plant has been analyzed for two externally initiated accidents: earthquakes and fire. The fire risk analysis has been performed through the estimates for consequences and risk measures,

whereas, as explained in Chapter 2, the seismic analysis has been conducted up to containment performance. Sensitivity analyses of seismic risk at Peach Bottom are provided in Reference 4.2.

Results of fire risk analysis (variabilities in mean risks estimated from the meteorology-averaged conditional mean values of the consequence measures) of Peach Bottom are shown in Figures 4.16 through 4.18 for early fatality, latent cancer fatality, population dose (within 50 miles of the site and within the entire site region), and individual early and latent cancer fatality risks. Major contributions to early and latent cancer fatality risks are shown in Figure 4.19. As can be seen, early and latent cancer fatality risks for fire at Peach Bottom are dominated by early containment failure and drywell failure caused by drywell meltthrough and loads at vessel breach. Other risk measures are slightly higher than those for internally initiated events but well below NRC safety goals.

4.6.2 Important Plant Characteristics (Risk)

The risk from the internal events are driven by long-term station blackout (SBO) and anticipated transients without scram (ATWS). The dominance of these two plant damage states can be attributed to both general BWR characteristics and plant-specific design. BWRs in general have more redundant systems that can inject into the reactor vessel than PWRs and can readily go to low pressure and use their low-pressure injection systems. This means that the dominant plant damage states will be driven by events that fail a multitude of systems (i.e., reduce the redundancy through some common-mode or support system failure) or events that only require a small number of systems to fail in order to reach core damage. The station blackout plant damage state satisfies the first of these requirements in that all systems ultimately depend upon ac power, and a loss of offsite power is a relatively high probability event. The total probability of losing ac power long enough to induce core damage is relatively high, although still low for a plant with Peach Bottom's design. The ATWS scenario is driven by the small number of systems that are needed to fail and the high stress upon the operators in these sequences.

4. Peach Bottom Plant Results

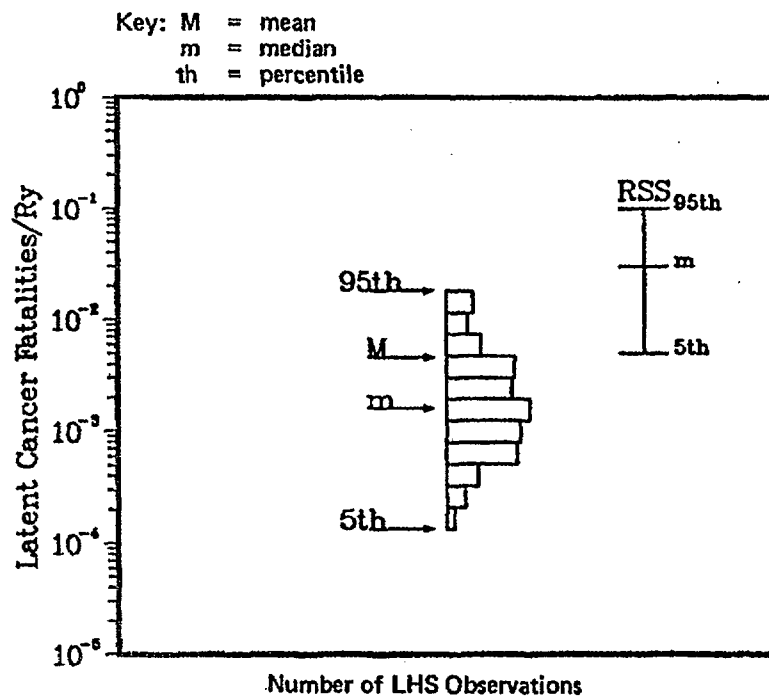
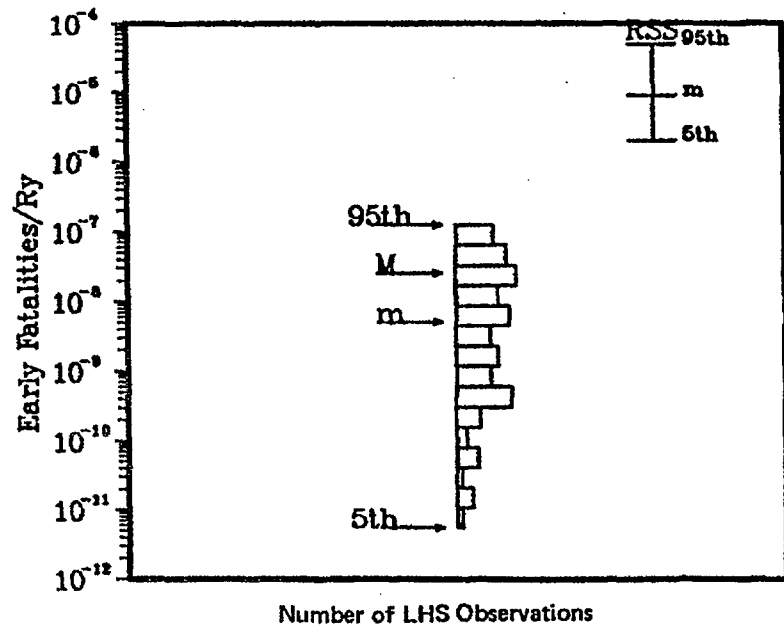

Note: As discussed in Reference 4.4, estimated risks at or below $1E-7$ per reactor year should be viewed with caution because of the potential impact of events not studied in the risk analyses.

Figure 4.11 Early and latent cancer fatality risks at Peach Bottom (internal initiators).

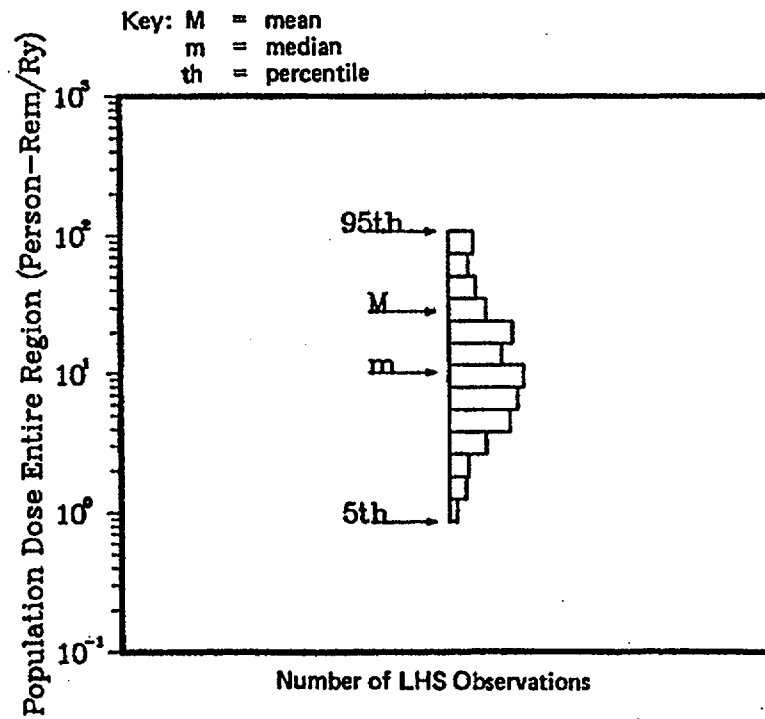
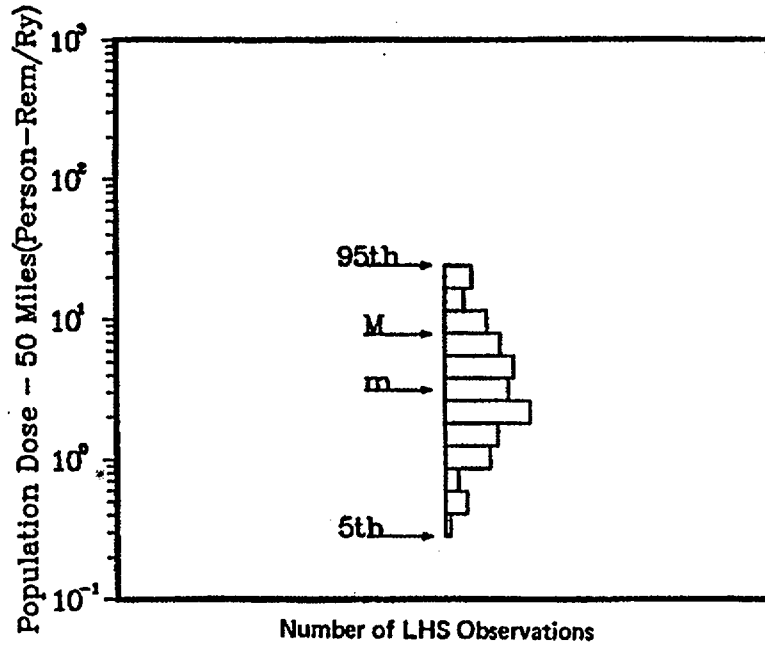

Note: As discussed in Reference 4.4, estimated risks at or below $1E-7$ per reactor year should be viewed with caution because of the potential impact of events not studied in the risk analyses.

Figure 4.12 Population dose risks at Peach Bottom (internal initiators).

4. Peach Bottom Plant Results

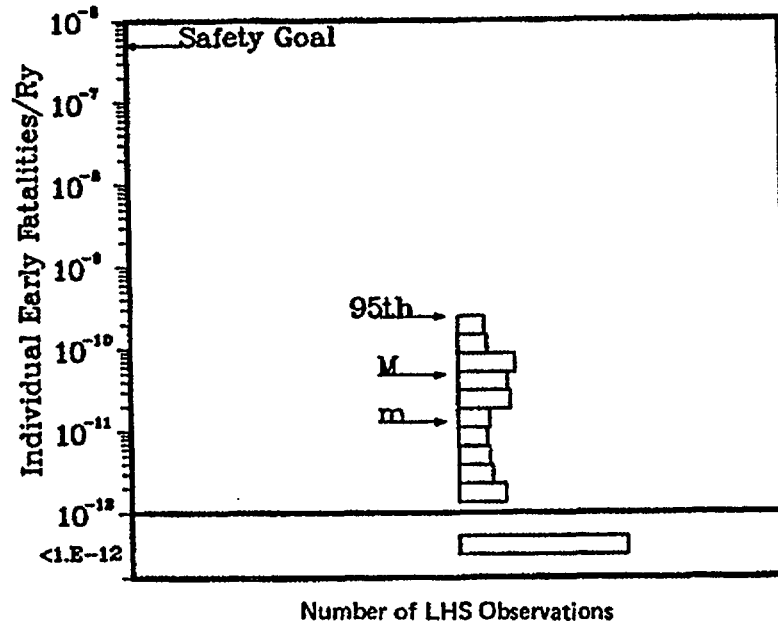

Key: M = mean
 m = median
 th = percentile

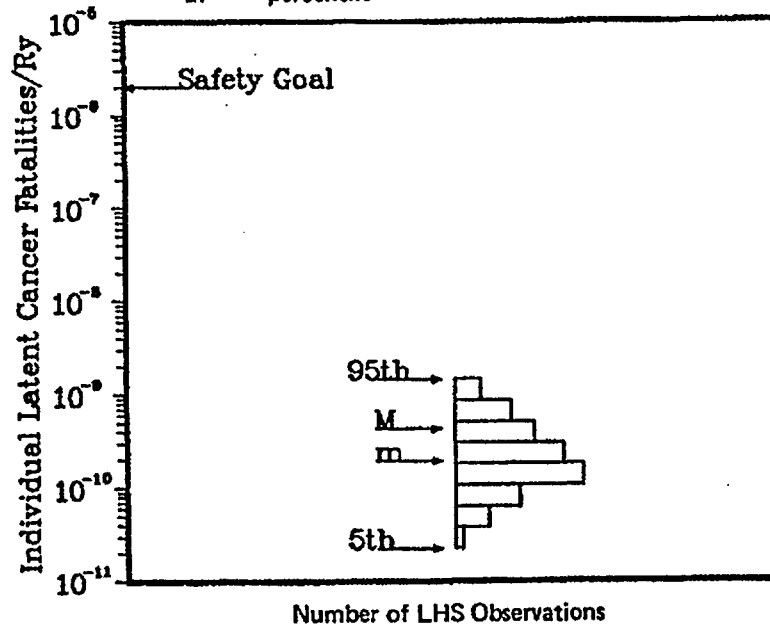

Note: As discussed in Reference 4.4, estimated risks at or below $1E-7$ per reactor year should be viewed with caution because of the potential impact of events not studied in the risk analyses.

Figure 4.13 Individual early and latent cancer fatality risks at Peach Bottom (internal initiators).

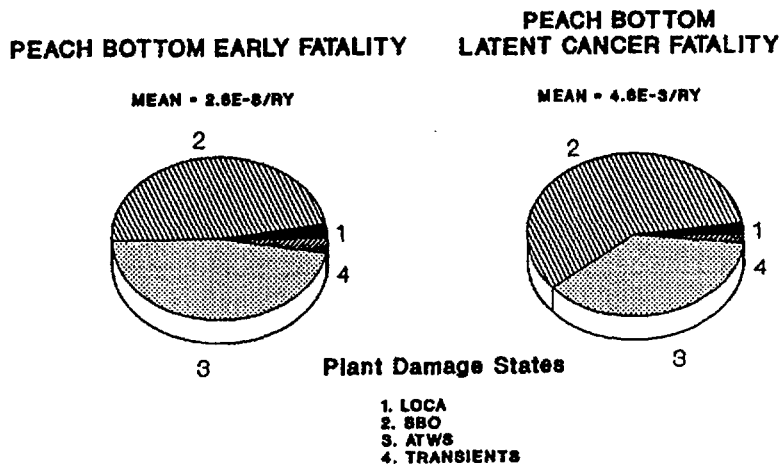

Figure 4.14 Major contributors (plant damage states) to mean early and latent cancer fatality risks at Peach Bottom (internal initiators).

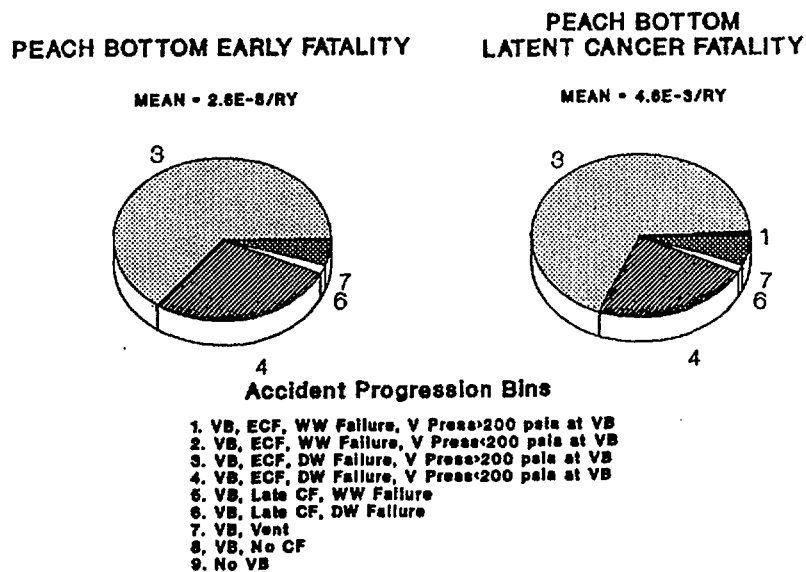
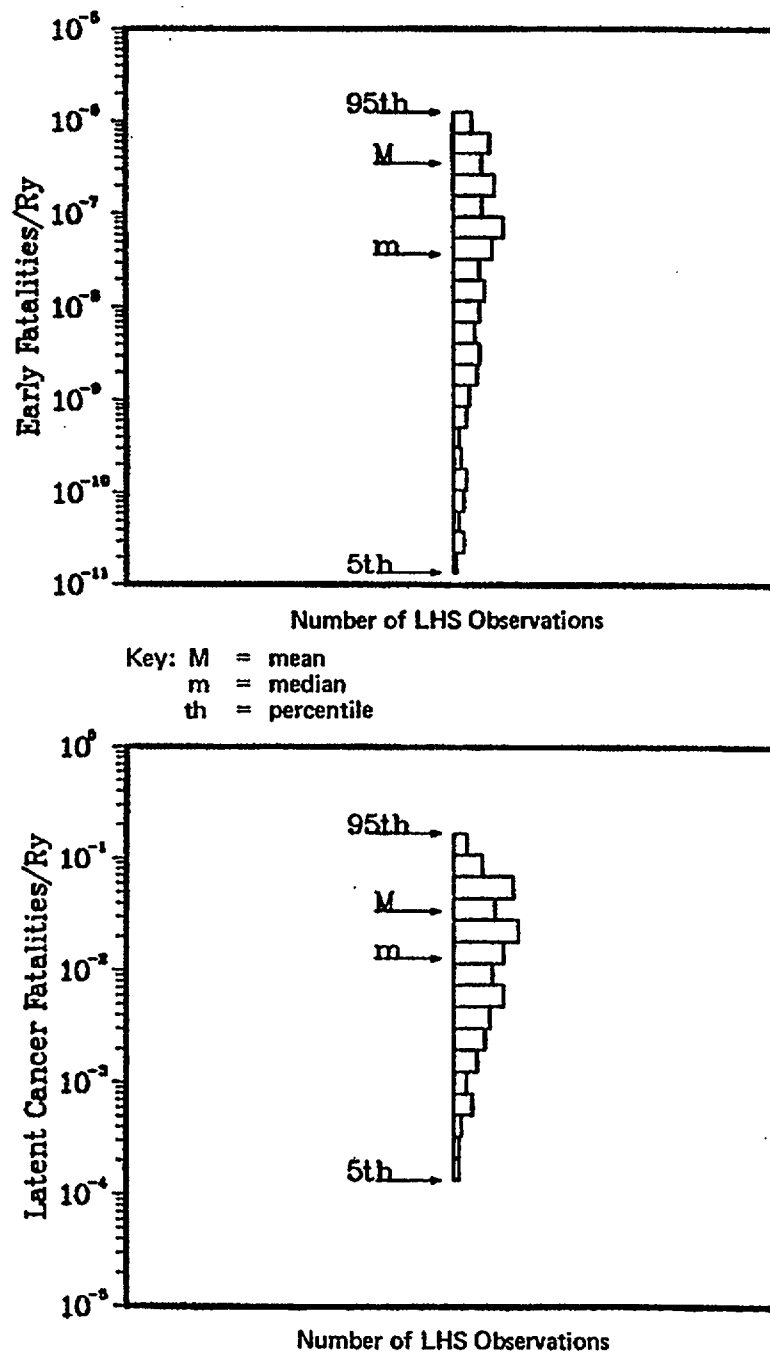

Figure 4.15 Major contributors (accident progression bins) to mean early and latent cancer fatality risks at Peach Bottom (internal initiators).

4. Peach Bottom Plant Results



Note: As discussed in Reference 4.4, estimated risks at or below $1E-7$ per reactor year should be viewed with caution because of the potential impact of events not studied in the risk analyses.

Figure 4.16 Early and latent cancer fatality risks at Peach Bottom (fire initiators).

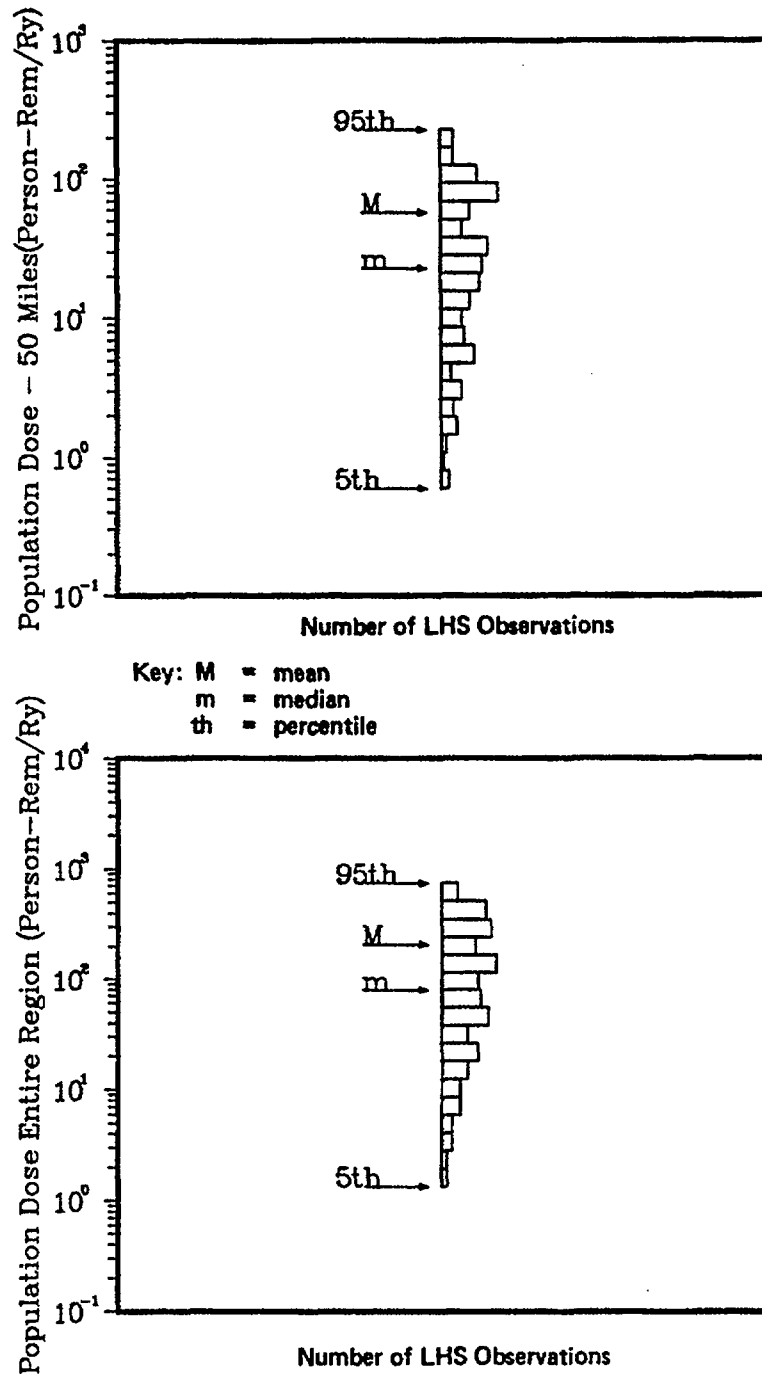

Note: As discussed in Reference 4.4, estimated risks at or below $1E-7$ per reactor year should be viewed with caution because of the potential impact of events not studied in the risk analyses.

Figure 4.17 Population dose risks at Peach Bottom (fire initiators).

4. Peach Bottom Plant Results

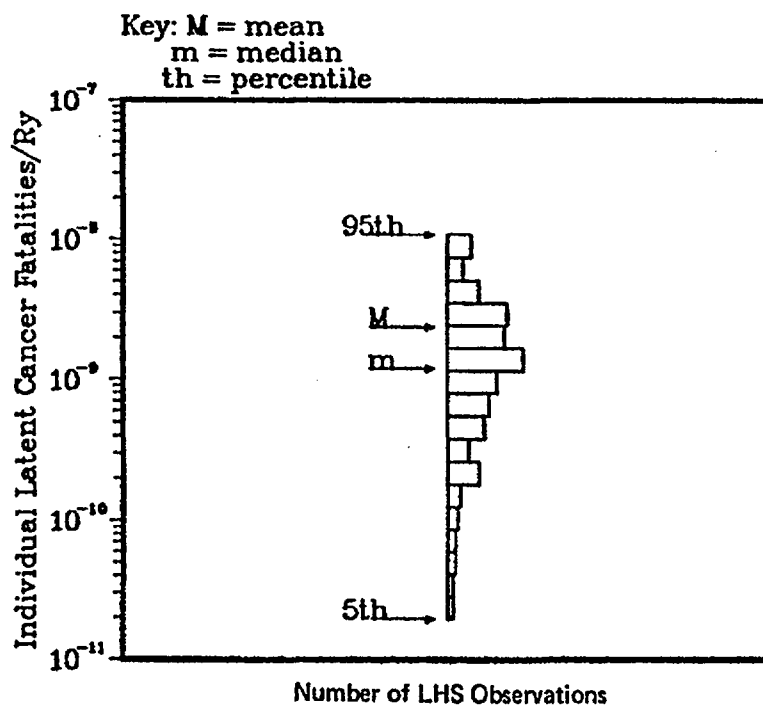
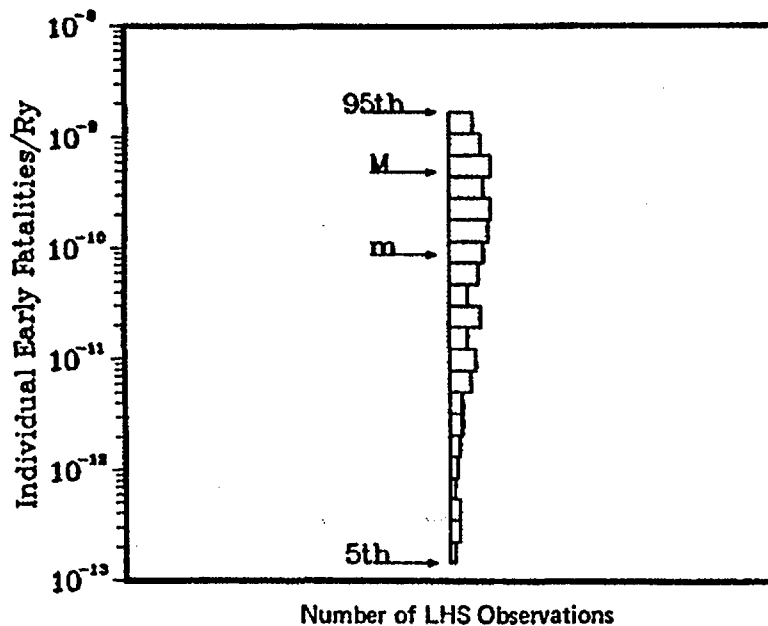

Note: As discussed in Reference 4.4, estimated risks at or below $1E-7$ per reactor year should be viewed with caution because of the potential impact of events not studied in the risk analyses.

Figure 4.18 Individual early and latent cancer fatality risks at Peach Bottom (fire initiators).

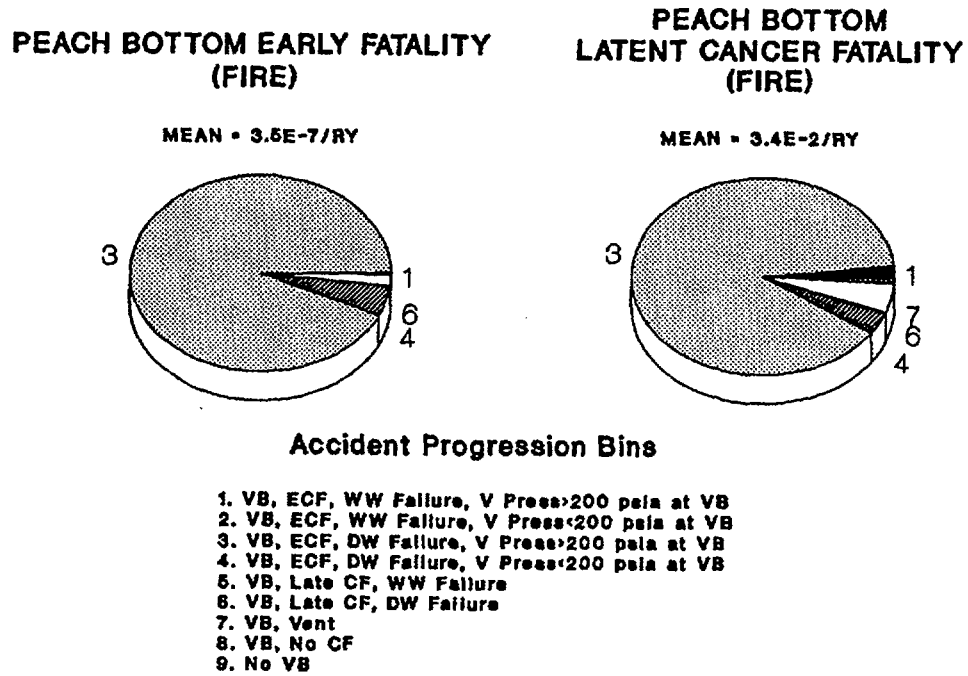

Figure 4.19 Major contributors (accident progression bins) to mean early and latent cancer fatality risks at Peach Bottom (fire initiators).

REFERENCES FOR CHAPTER 4

- 4.1 A. M. Kolaczowski et al., "Analysis of Core Damage Frequency: Peach Bottom Unit 2," Sandia National Laboratories, NUREG/CR-4550, Vol. 4, Revision 1, SAND86-2084, August 1989.
- 4.2 A. C. Payne, Jr., et al., "Evaluation of Severe Accident Risks: Peach Bottom Unit 2," Sandia National Laboratories, NUREG/CR-4551, Vol. 4, Draft Revision 1, SAND86-1309, to be published.*
- 4.3 USNRC, "Reactor Safety Study—An Assessment of Accident Risks in U.S. Commercial Nuclear Power Plants," WASH-1400 (NUREG-75/014), October 1975.
- 4.4 H. J. C. Kouts et al., "Special Committee Review of the Nuclear Regulatory Commission's Severe Accident Risks Report (NUREG-1150)," NUREG-1420, August 1990.
- 4.5 D. L. Bernreuter et al., "Seismic Hazard Characterization of 69 Nuclear Power Sites East of the Rocky Mountains," Lawrence Livermore National Laboratory, NUREG/CR-5250, Vols. 1-8, UCID-21517, January 1989.
- 4.6 Seismicity Owners Group and Electric Power Research Institute, "Seismic Hazard Methodology for the Central and Eastern United States," EPRI NP-4726, July 1986.
- 4.7 A. D. Swain III, "Accident Sequence Evaluation Program—Human Reliability Analysis Procedure," Sandia National Laboratories, NUREG/CR-4772, SAND86-1996, February 1987.
- 4.8 W. J. Luckas, Jr., "A Human Reliability Analysis for the ATWS Accident Sequence with MSIV Closure at the Peach Bottom Atomic Power Station," Brookhaven National Laboratory, May 1986.
- 4.9 Philadelphia Electric Company, "Evacuation Time Estimates with the Plume Exposure Pathway Emergency Planning Zone for the Peach Bottom Atomic Power Station," Rev. 0, July 1982.
- 4.10 USNRC, "Safety Goals for the Operation of Nuclear Power Plants; Policy Statement," *Federal Register*, Vol. 51, p. 30028, August 21, 1986.

*Available in the NRC Public Document Room, 2120 L Street NW., Washington, DC.

5. SEQUOYAH PLANT RESULTS

5.1 Summary Design Information

The Sequoyah Nuclear Power Plant is a two-unit site. Each unit, designed by Westinghouse Corporation, is a four-loop pressurized water reactor (PWR) rated at 1148 MWe and is housed in an ice condenser containment. The balance of plant systems were engineered and built by the utility, the Tennessee Valley Authority. Sequoyah 1 started commercial operation in 1981. Some important design features of the Sequoyah plant are described in Table 5.1. A general plant schematic is provided in Figure 5.1.

This chapter provides a summary of the results obtained in the detailed risk analyses underlying this report (Refs. 5.1 and 5.2). A discussion of perspectives with respect to these results is provided in Chapters 8 through 12.

5.2 Core Damage Frequency Estimates

5.2.1 Summary of Core Damage Frequency Estimates

The core damage frequency and risk analyses performed for this study considered accidents initiated only by internal events (Ref. 5.1); no external-event analyses were performed. The core damage frequency results obtained are provided in tabular form in Table 5.2 and in graphical form, displayed as a histogram, in Figure 5.2 (Section 2.2.2 discusses histogram development). This study calculated a total median core damage frequency from internal events of $3.7E-5$ per year.

5.2.1.1 Internally Initiated Accident Sequences

Twenty-three individual accident sequences were identified as important to the core damage frequency estimates for Sequoyah. A detailed description of these accident sequences is provided in Reference 5.1. For the purpose of discussion here, the accident sequences have been grouped into five summary plant damage states. These are:

- Station blackout,
- Loss-of-coolant accidents (LOCAs),
- Anticipated transients without scram (ATWS),

- Transients other than station blackout and ATWS, and
- Interfacing-system LOCA and steam generator tube rupture (bypass accidents).

The relative contributions of these groups to the total mean core damage frequency at Sequoyah is shown in Figure 5.3. It is seen that loss-of-coolant accidents as a group are the largest contributors to core damage frequency. Within the general class of loss-of-coolant accidents, the most probable combinations of failures are:

- Intermediate ($2" < D < 6"$), small ($1/2 < D < 2"$), and very small ($D < 1/2"$) size LOCAs in the reactor coolant system piping followed by failure of high-pressure or low-pressure emergency coolant recirculation from the containment sump. Coolant recirculation from the containment sump can fail because of valve failures, pump failures, plugging of drains or strainers, or operator failure to correctly reconfigure the emergency core cooling system (ECCS) equipment for the recirculation mode of operation.

Station blackout sequences as a group are the second largest contributor to core damage frequency. Within this group, the most probable combinations of failures are:

- Station blackout with failure of the auxiliary feedwater (AFW) system. Core uncover is caused by failure of the AFW system to provide steam generator feed flow, thus causing gradual heatup and boiloff of reactor coolant. Station blackout also results in the unavailability of the high-pressure injection systems for feed and bleed. The dominant contributors to this sequence are the station blackout followed by initial turbine-driven AFW pump unavailability due to mechanical failure or maintenance outage, or failure of the operator to open air-operated valves after depletion of the instrument air supply.
- Station blackout with initial AFW operation that fails at a later time because of battery depletion or station blackout, with reactor coolant pump (RCP) seal LOCA because of loss of all RCP seal cooling. Station blackout results in a loss of seal injection flow to the RCPs and a loss of component cooling water to the RCP thermal barriers. This condition results in vulnerability of the RCP seals to

5. Sequoyah Plant Results

Table 5.1 Summary of design features: Sequoyah Unit 1.

| | |
|---|---|
| 1. Coolant Injection System | <ul style="list-style-type: none"> a. Charging system provides safety injection flow, emergency boration, feed and bleed cooling, and normal seal injection flow to the RCPs,* with 2 centrifugal pumps. b. RHR system provides low-pressure emergency coolant injection and recirculation following LOCA, with 2 trains and 2 pumps. c. Safety injection system provides high head safety injection and feed and bleed cooling, with 2 trains and 2 pumps. |
| 2. Steam Generator Heat Removal Systems | <ul style="list-style-type: none"> a. Power conversion system. b. Auxiliary feedwater system, with 3 trains and 3 pumps (2 MDPs, 1 TDP).* |
| 3. Reactivity Control Systems | <ul style="list-style-type: none"> a. Control rods. b. Chemical and volume control systems. |
| 4. Key Support Systems | <ul style="list-style-type: none"> a. dc power, with 2-hour station batteries. b. Emergency ac power, with 2 diesel generators for each unit, each diesel generator dedicated to a 6.9 kV emergency bus (these buses can be crosstied to each other via a shutdown utility bus). c. Component cooling water provides cooling water to RCP* thermal barriers and selected ECCS equipment, with 5 pumps and 3 heat exchangers for both Units 1 and 2. d. Service water system, with 8 self-cooled pumps for both Units 1 and 2. |
| 5. Containment Structure | <ul style="list-style-type: none"> a. Ice condenser. b. 1.2 million cubic feet. c. 10.8 psig design pressure. |
| 6. Containment Systems | <ul style="list-style-type: none"> a. Spray system provides containment pressure-suppression during the injection phase following a LOCA and also provides containment heat removal during the recirculation phase following a LOCA. b. System of igniters installed to burn hydrogen. c. Air-return fans to circulate atmosphere through the ice condenser and keep containment atmosphere well mixed. |

*MDP: Motor-Driven Pump
 TDP: Turbine-Driven Pump
 RCP: Reactor Coolant Pump

5. Sequoyah Plant Results

Table 5.2 Summary of core damage frequency results: Sequoyah.*

| | 5% | Median | Mean | 95% |
|------------------|---------|--------|--------|--------|
| Internal Events | 1.2E-5 | 3.7E-5 | 5.7E-5 | 1.8E-4 |
| Station Blackout | | | | |
| Short Term | 4.2E-7 | 3.8E-6 | 9.6E-6 | 3.6E-5 |
| Long Term | 1.0E-7 | 1.4E-6 | 5.0E-6 | 1.7E-5 |
| ATWS | 4.3E-8 | 5.3E-7 | 1.9E-6 | 7.5E-6 |
| Transient | 2.5E-7 | 1.1E-6 | 2.6E-6 | 7.2E-6 |
| LOCA | 4.4E-6 | 1.8E-5 | 3.6E-5 | 1.2E-4 |
| Interfacing LOCA | 1.5E-11 | 2.0E-8 | 6.5E-7 | 2.1E-6 |
| SGTR | 2.4E-8 | 4.1E-7 | 1.7E-6 | 7.1E-6 |

*As discussed in Reference 5.3, core damage frequencies below 1E-5 per reactor year should be viewed with caution because of the remaining uncertainties in PRA (e.g., events not considered).

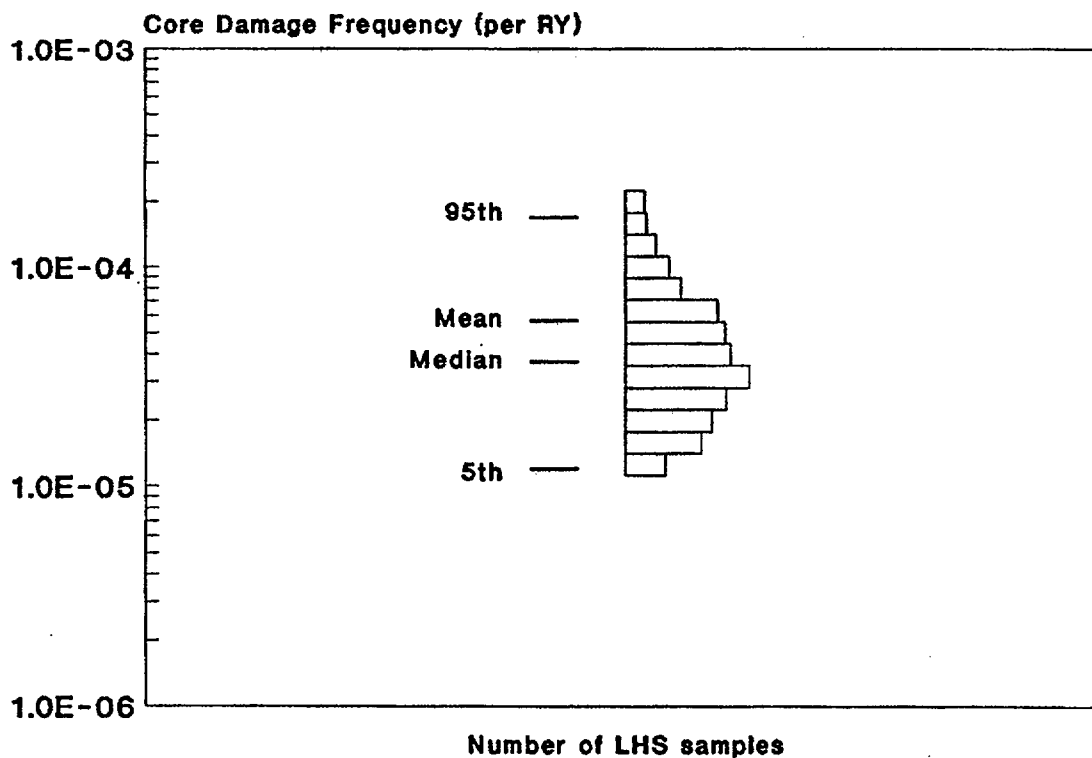

Note: As discussed in Reference 5.3, core damage frequencies below 1E-5 per reactor year should be viewed with caution because of the remaining uncertainties in PRA (e.g., events not considered).

Figure 5.2 Internal core damage frequency results at Sequoyah.

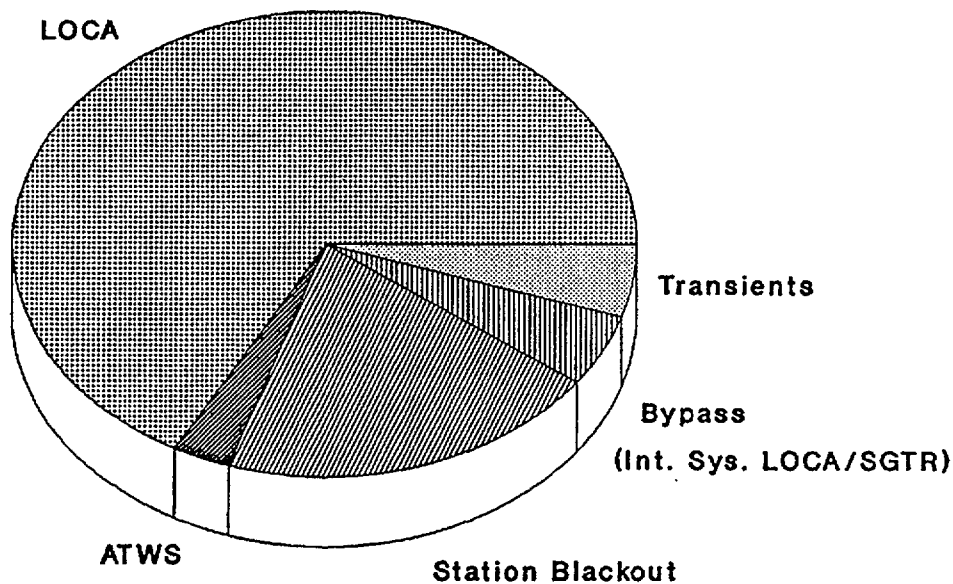

Total Mean Core Damage Frequency: 5.7E-5

Figure 5.3 Contributors to mean core damage frequency from internal events at Sequoyah.

failure. The failure to restore ac power and safety injection flow following any seal LOCA leads to core uncover. The time to core uncover following onset of a seal LOCA is a function of the leak rate and whether or not the operator takes action to depressurize the reactor coolant system.

Within the general group of containment bypass accidents, the more probable combinations of failure are:

- Steam generator tube rupture, followed by failure to depressurize the reactor coolant system (RCS). Subsequent failure to depressurize the RCS in the long term and thus limit RCS leakage leads to continued blowdown through the steam generator and eventual core uncover. An important event in this sequence is the initial failure of the operator to depressurize within 45 minutes after the tube rupture. This leads to a relief valve demand in the secondary cooling system. The steam generator safety valve will be demanded if the power-operated relief valve is blocked. Subsequent failure of the PORV or safety valve to reclose leads to direct loss of RCS inventory to the atmosphere. Failure of subsequent efforts to recover the sequence by RCS depressurization or closure of the PORV or safety valve leads to refueling water storage tank inventory depletion and eventual core uncover.
- Failure of RCS pressure isolation leading to LOCAs in systems interfacing with the reactor coolant system (by overpressurization of low-pressure piping in the interfacing system). These sequences comprise 2 percent of the total core damage frequency but are important contributors to risk because they create a direct release path to the environment. These accidents are of special interest because they prevent ECCS operation in the recirculation mode and lead to containment bypass.

5. Sequoyah Plant Results

5.2.2 Important Plant Characteristics (Core Damage Frequency)

Characteristics of the Sequoyah plant design and operation that have been found to be important in the analysis of core damage frequency include:

1. Electric Power Crossconnects Between Units 1 and 2

The Sequoyah electric power system design includes the capability to crosstie the 6.9 kV emergency buses at Unit 1 and Unit 2 and includes the capability to energize dc battery boards at Unit 1 from the batteries at Unit 2. These crossties help reduce the frequency of station blackout at Unit 1 and significantly reduce the possibility of battery depletion as an important contributor for those station blackouts that are postulated to occur. The crossties reduce the station blackout core damage frequency by less than a factor of 2. As station blackout sequences only account for 20 percent of the total core damage frequency, the crossties reduce total core damage frequency by approximately 10 percent.

2. Transfer to Emergency Core Cooling and Containment Spray System Recirculation Mode

The process for switching the emergency core cooling system and the containment spray system from the injection mode to the recirculation mode at Sequoyah involves a series of operator actions that must be accomplished in a relatively short time (~20 minutes) and are only partially automated. Therefore, operator action is required to maintain core cooling when switching over to the recirculation mode. Single operator errors during switchover from injection to recirculation following a small LOCA can lead directly to core uncover. Recirculation failure can also result from common-cause failures affecting the entire emergency core cooling system and containment spray system. These failures include level sensor miscalibration for the refueling water storage tank and failure to remove the upper containment compartment drain plugs after refueling.

3. Loss of Coolant from Interfacing-System LOCA

Interfacing-system LOCA results from failures of any one of the four pairs of series

check valves used to isolate the high-pressure RCS from the low-pressure injection system. The resultant flow into the low-pressure system is assumed to result in rupture of the low-pressure piping or components outside the containment boundary. Although core inventory makeup by the high-pressure injection system is initially available, the inability to switch to the recirculation mode would eventually lead to core damage. Because of the location of the postulated LOCA, all containment safeguards are bypassed.

The failure scenarios of interest are those that produce a sudden large backleakage from the RCS that cannot be accommodated by relief valves in the low-pressure systems. Interfacing-system LOCA could therefore occur in two ways:

- a. Random or dependent rupture of valve internals on both valves. Rupture of the upstream valve would go undetected until rupture of the second valve occurred, and
- b. Rupture of the downstream valve combined with the failure of the upstream valve to be closed on demand. This scenario has an extremely low probability at Sequoyah because the check valve testing procedures require leak rate testing after each valve use.

If an interfacing-system LOCA should occur, a potential recovery action was identified and considered in the analysis in which the operator may be able to isolate the interfacing-system LOCA by closing the appropriate low-pressure injection cold leg isolation valve.

4. Diesel Generators

Sequoyah is a two-unit site with four diesel generator units. Each diesel is dedicated to a particular (6.9 kV) emergency bus at one of the units. Each diesel generator can only be connected to its dedicated emergency bus. However, the 6.9 kV buses can be crosstied to each other through the use of the shutdown utility bus, thus providing an indirect way to crosstie diesels and emergency buses. The diesel generators have dedicated batteries for starting and can be loaded on the emergency buses manually or with alternative power supplies. Emergency ac power is therefore not as susceptible to failures of the station batteries as at those plants where station batteries are used for diesel startup.

5. Containment Design

The ice condenser containment design is important to estimates of core damage frequency because of the spray actuation setpoints. The relatively low-pressure setpoints result in spray actuation for a significant percentage of small LOCAs. The operation of the sprays will deplete the refueling water storage tank (RWST) in approximately 20 minutes, thus requiring fast operator intervention to switch over to recirculation mode. The reduced time available for operator action results in an increased human error rate for recirculation alignment associated with this time interval.

5.2.3 Important Operator Actions

Several operator actions are very important in preventing core uncover. These actions are discussed in this section with respect to the accident sequence in which they occur.

- Switchover to ECCS recirculation in a small LOCA

There are four major operator actions during recirculation switchover:

- Switchover of high-pressure emergency core cooling system (ECCS) from injection to recirculation.
- Isolation of ECCS suction from RWST.
- Switchover of containment spray system (CSS) from injection to recirculation, including isolation of suction from the RWST.
- Valving in component cooling water (CCW) to the residual heat removal (RHR) heat exchangers.

- Control of containment sprays during small LOCAs

Virtually all small LOCAs will result in automatic containment spray actuation. If the operator does not control sprays early during a small LOCA, the RWST level will decrease and switchover to recirculation will be required.

All actions are performed in the main control room at one location. The time for diagnosis is relatively short (~20 minutes) for determin-

ing if the event is actually a LOCA and anticipating whether high-pressure recirculation will be needed when the low RWST level alarm is actuated.

- Feed and bleed cooling

For accident sequences in which main and auxiliary feedwater are unavailable, feed and bleed cooling can be used to remove decay heat from the core. The operator is instructed to initiate feed and bleed cooling if steam generator levels drop below 25 percent. This point is reached approximately 30 minutes after auxiliary feedwater (AFW) and main feedwater become unavailable.

- Anticipated transients without scram (ATWS)

Five operator actions could potentially be required during an ATWS sequence, depending on the particular course of the sequence. These events are:

- Manual reactor trip.
- Trip turbine if not done automatically.
- Start AFW if not started automatically.
- Open block valve on power-operated relief valve (PORV) within 2 minutes if PORV is isolated previous to initiating event.
- Emergency boration, if manual trip failed.

Due to the fast-acting nature of an ATWS, all ATWS actions must be performed from memory.

- Steam generator tube rupture

Steam generator tube rupture (SGTR) accident sequences are considered to begin with a double-ended rupture of a single steam generator tube. Very shortly thereafter, a safety injection signal will occur on low RCS pressure. The immediate concern for the operator, after identifying the event as an SGTR, is to identify and isolate the ruptured steam generator. There are three possible operator actions during an SGTR. These are:

- Cool down and depressurize the RCS very shortly (~45 minutes) after the

5. Sequoyah Plant Results

event in order to prevent lifting the relief valves on the affected steam generator;

- Restore the main feedwater flow in the event of a loss of auxiliary feed flow; and
 - Isolate the steam generator that contains the ruptured tube.
- Interfacing-system LOCA recovery action

The two RHR trains are physically isolated from each other and are provided with system isolation capability. To recover from an interfacing-system LOCA in the RHR system and to continue core cooling, the break must first be isolated and the reactor coolant system refilled. Since the RHR valves are not designed to close against the pressure differentials present during the blowdown, isolation of the affected loop and operation of the unaffected loop must be accomplished following blowdown. The RHR valves can be closed from the control room. No credit for local action is given because of the steam environment following the blowdown.

5.2.4 Important Individual Events and Uncertainties (Core Damage Frequency)

As discussed in Chapter 2, the process of developing a probabilistic model of a nuclear power plant involves the combination of many individual events (initiators, hardware failures, operator errors, etc.) into accident sequences and eventually into an estimate of the total frequency of core damage. After development, such a model can also be used to assess the importance of the individual events. The detailed studies underlying this report have been analyzed using several event importance measures. The results of the analyses using two measures, "risk reduction" and "uncertainty" importance, are summarized below.

- Risk (core damage frequency) reduction importance measure (internal events)

The risk-reduction importance measure is used to assess the change in core damage frequency as a result of setting the probability of an individual event to zero. Using this measure, the following individual events were found to cause the greatest reduction in core

damage frequency if their probabilities were set to zero:

- Very small LOCA initiating event. The core damage frequency will be reduced by approximately 38 percent.
 - Operator fails to control sprays during a small LOCA. The core damage frequency will be reduced by approximately 37 percent.
 - Loss of offsite power initiating event. The core damage frequency will be reduced by approximately 21 percent.
 - Operator failure to properly align high-pressure recirculation. The core damage frequency will be reduced by approximately 15 to 20 percent.
 - Failure to recover diesel generators within 1 hour. The core damage frequency will be reduced by approximately 14 percent.
 - Failure to recover ac power within 1 hour. The core damage frequency will be reduced by approximately 13 percent.
 - Intermediate LOCA initiating events. The core damage frequency will be reduced by approximately 12 percent.
 - Small LOCA initiating events. The core damage frequency will be reduced by approximately 13 percent.
- Uncertainty importance measure (internal events)

A second importance measure used to evaluate the core damage frequency analysis results is the uncertainty importance measure. For this measure, the relative contribution of the uncertainty of individual events to the uncertainty in total core damage frequency is calculated. Using this measure, the largest contributors to uncertainty in the results are the human error probabilities for failure to reconfigure the ECCS for high-pressure recirculation. All other events contribute relatively little to the uncertainty in overall core damage frequency.

5.3 Containment Performance Analysis

5.3.1 Results of Containment Performance Analysis

The Sequoyah primary containment consists of a pressure-suppression containment system, i.e., ice condenser, which houses the reactor pressure vessel, reactor coolant system, and the steam generators for the secondary side steam supply system. The containment system is comprised of a steel vessel surrounded by a concrete shield building enclosing an annular space. The internal containment volume, which has a total capacity of 1.2 million cubic feet, is divided into two major compartments connected by the ice condenser system, with the reactor coolant system occupying the lower compartment. The ice condenser is essentially a cold storage ice-filled room 50 feet in height, bounded on one side by the steel containment wall. The design basis pressure for Sequoyah's ice condenser containment is 10.8 psig, whereas its estimated mean failure pressure is 65 psig. This low-pressure design combined with the relatively small free volume made hydrogen control a design basis consideration, i.e., recombiners, and also a major consideration with respect to containment integrity for severe accidents, i.e., igniters and air-return fans. Similar to other containment design analyses for this study, the estimate of where and when Sequoyah's containment will fail relied heavily on the use of expert judgment to interpret and supplement the limited data available (Ref. 5.4).

The potential for early containment failure has been of considerable concern for Sequoyah since the steel containment has such a low design pressure. The principal mechanisms threatening the containment are hydrogen combustion effects, overpressurization due to direct containment heating, failure of the wall by direct contact with molten core material, and isolation failures.

The results of the Sequoyah containment analysis are summarized in Figures 5.4 and 5.5. Figure 5.4 displays information in which the conditional probabilities of ten containment-related accident progression bins; e.g., VB-early CF (during CD), are presented for each of five plant damage states. This information indicates that, on a frequency-weighted average,* the mean conditional probability from internal events of (1) early contain-

*Each value in the column in Figure 5.4 labeled "All" is obtained by calculating the products of individual accident progression bin conditional probabilities for each plant damage state and the ratio of the frequency of that plant damage state to the total core damage frequency.

ment failure due to effects such as hydrogen combustion, direct containment heating, and wall contact failure is 0.07, (2) late containment failure due primarily to basemat meltthrough is 0.21, (3) containment bypass is 0.06, and (4) probability of no containment failure or no vessel breach is 0.66. It should be noted, however, that the conditional probabilities of early containment failure for the loss of offsite power (LOSP) plant damage state are considerably higher than the averaged values, i.e., about 0.13 for LOSP sequences involving vessel breach and 0.17 when those LOSP sequences having no vessel breach are included. Figure 5.5 further develops the conditional probability distribution of early containment failure for each of the plant damage states, providing the estimated range of uncertainties in the containment failure predictions. Overall conclusions that can be drawn from this information are discussed in Chapter 9. However, it should be noted that Sequoyah's early containment failure probability depends heavily on the accuracy of our predictions of core arrest probability, direct containment heating, hydrogen combustion, and wall attack effects.

Additional discussions on containment performance (for all studied plants) are provided in Chapter 9.

5.3.2 Important Plant Characteristics (Containment Performance)

Characteristics of the Sequoyah design and operation that are important to containment performance include:

1. Pressure-Suppression Design

The Sequoyah ice condenser suppression design can have a significant effect on certain accident sequence risk results. For example, the availability of ice in the ice condenser can reduce the risk significantly from events involving steam or direct containment heating threats to the containment. In contrast, its availability during some station blackout sequences can result in a potentially combustible hydrogen concentration at the exit of the ice bed. Further discussion of the ice condenser pressure-suppression system relative to other PWR dry containments is contained in Chapter 9.

2. Hydrogen Ignition System

The Sequoyah hydrogen ignition system will significantly reduce the threat to containment from uncontrolled hydrogen combustion

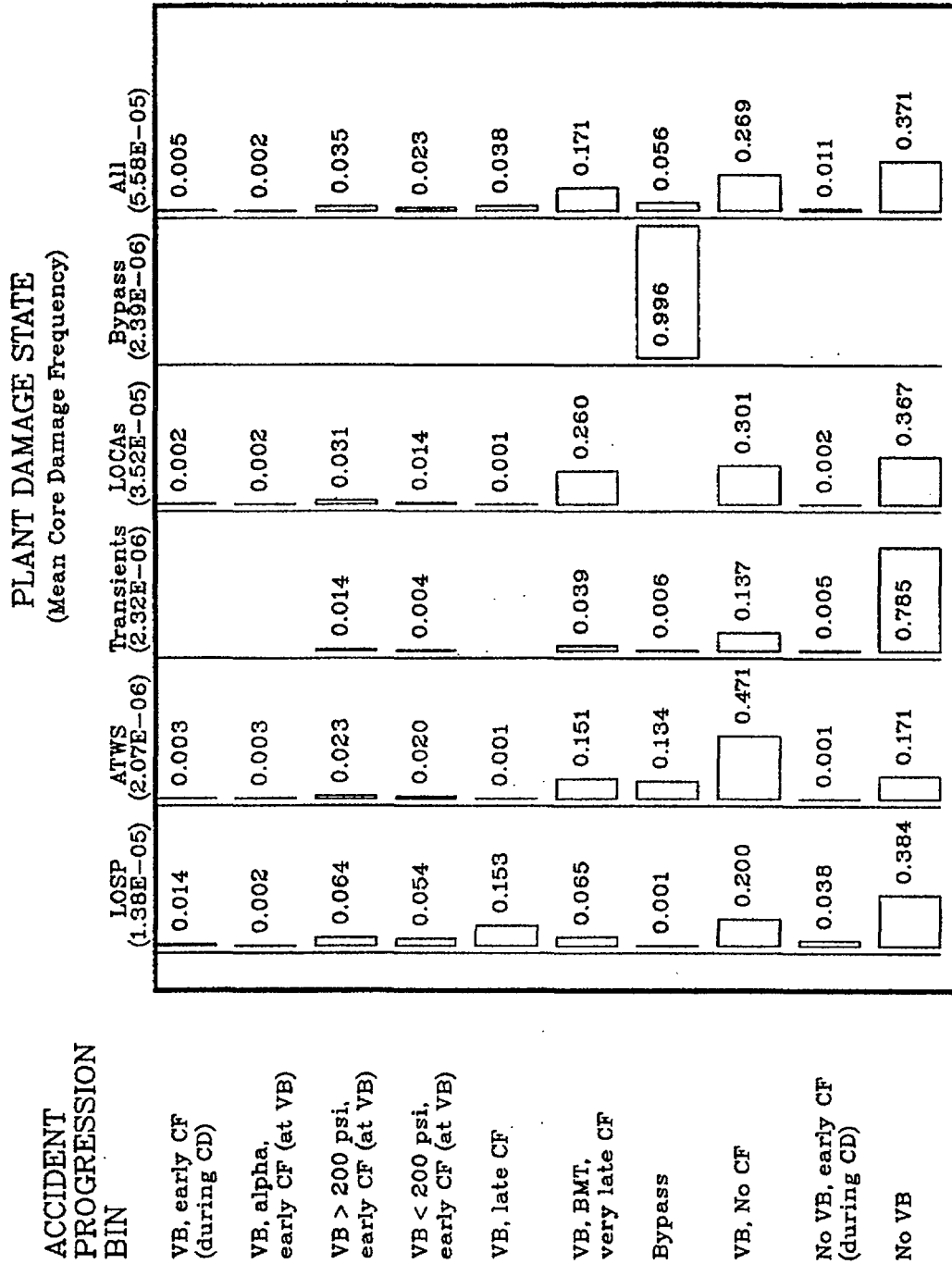

BMT = Basemat Melthrough
 CF = Containment Failure
 VB = Vessel Breach
 CD = Core Degradation

Figure 5.4 Conditional probability of accident progression bins at Sequoyah.

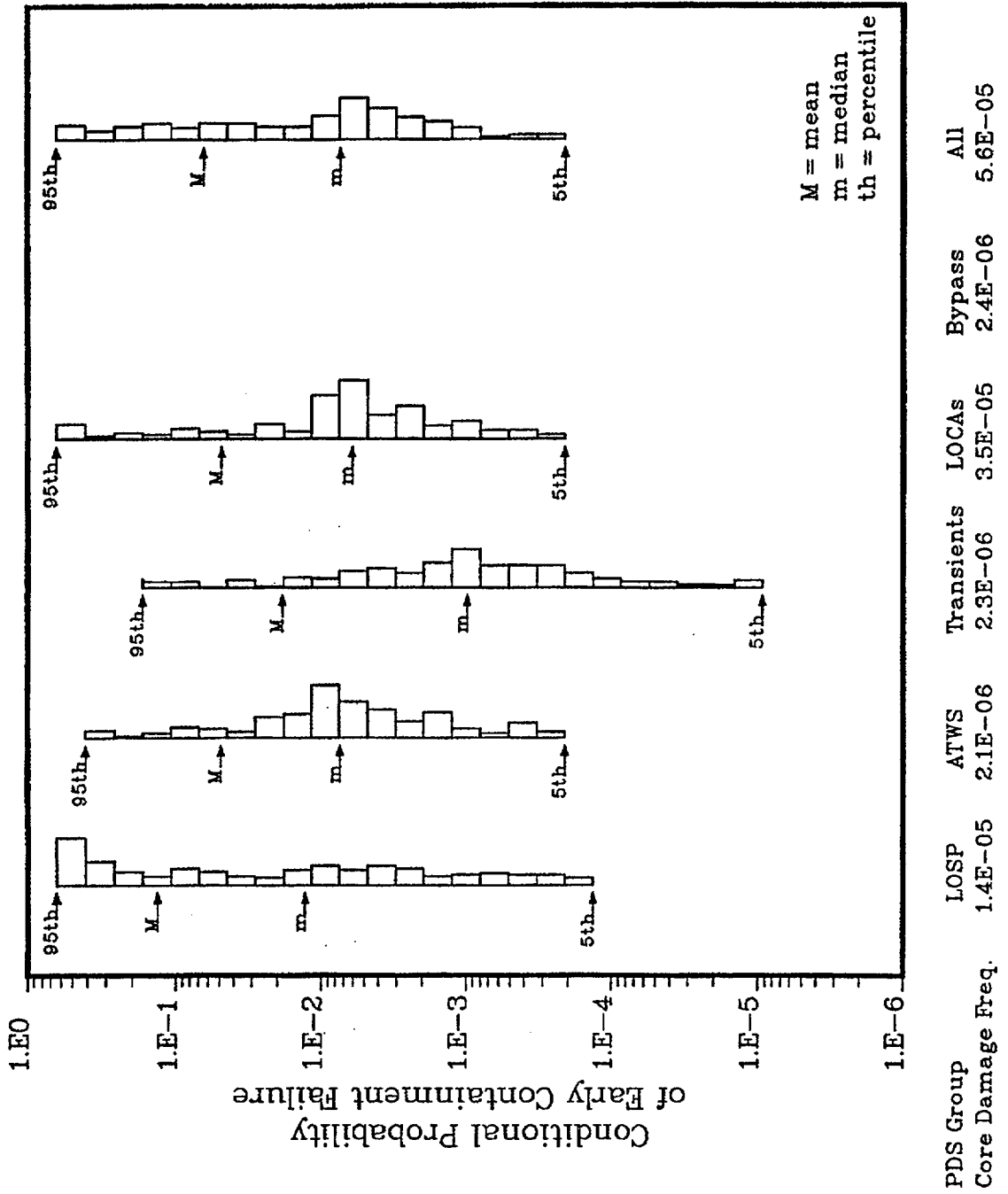

Figure 5.5 Conditional probability distributions for early containment failure at Sequoyah.

5. Sequoyah Plant Results

effects except for station blackout sequences. However, when power is recovered following a station blackout, if the igniters are turned on before the air-return fans have diluted the hydrogen concentration at or above the ice beds, the ignition could trigger a detonation or deflagration that could fail containment. These blackout sequences, however, represent a small fraction of the overall frequency of core damage.

3. Lower Compartment Design

The design and construction of the seal table is such that if the reactor coolant system is at an elevated pressure upon vessel breach, the core debris is likely to get into the seal table room, which is directly in contact with the containment, and melt through the wall causing a break of containment. The design of the reactor cavity, however, does have the potential to cool the molten core debris and also mitigate the effects of potential direct containment heating events for those sequences where water is in the reactor cavity.

5.4 Source Term Analysis

5.4.1 Results of Source Term Analysis

The absolute frequencies of early containment failure from severe accident loads and of containment bypass are predicted to be similar for the Sequoyah plant (Ref. 5.2). Figure 5.6 illustrates the release fractions for an early containment failure accident progression bin. The mean values for the release of the volatile radionuclide groups are approximately 10 percent, indicative of an accident with the potential for causing early fatalities. The in-vessel releases in these accidents can be subject to decontamination by the ice bed or by containment sprays following release to the containment. The sprays require ac power and are, therefore, not available prior to power recovery in station blackout plant damage states. The decontamination factor of the ice bed is also affected by the unavailability of the recirculation fans during station blackout.

The location and mode of containment failure are particularly important for early containment failure accident progression bins. A substantial fraction of the early failures result in subsequent bypass of the ice bed. In particular, if the containment ruptures as the result of a sudden, high-pressure load, such as from hydrogen deflagration, the damage to the containment wall could be extensive and is likely to result in bypass.

In most accident sequences for Sequoyah, there is substantial water in the cavity that can either prevent core-concrete attack, if a coolable debris bed is formed, or mitigate the release of radionuclides during core-concrete attack by scrubbing in the overlaying water pool. As a result, a large release to the environment of the less volatile radionuclides that are released from fuel during core-concrete attack is unlikely for the Sequoyah plant.

In the station blackout plant damage state, containment failure can occur late in the accident as the result of hydrogen combustion following power recovery. Figure 5.7 illustrates the source terms for a late containment failure accident progression bin in which it is unlikely that water would be available to scrub the core-concrete releases. In this case, decontamination by the ice bed is important in mitigating the environmental release. As discussed previously, for very wide ranges of uncertainty covering many orders of magnitude, one or more high results can dominate the mean such that it falls above the 95th percentile.

5.4.2 Important Plant Characteristics (Source Term)

1. Ice Condenser

In addition to condensing steam, the ice beds can trap radioactive aerosols and vapors in a severe accident. The extent of decontamination is very sensitive to the volume fraction of steam in the flowing gas, which in turn depends on whether the air-return fans are operational. For a single pass through the ice condenser with high steam fraction, the range of decontamination factor used in this study was from 1.3 to 35 with a median of 7 for the in-vessel release and less than half as effective for the core-concrete release. For the low steam fraction scenarios with a single pass through the ice beds, the lower bound was approximately 1.1, the upper bound 8, and the median 2. The values used for multiple passes through the ice bed when the containment is intact and the air-return fans are running are only slightly larger, with a median value of 3. Thus, the credit for ice bed retention is substantially less than the values used for the decontamination effectiveness of suppression pools in the BWRs.

2. Cavity Configuration

The Sequoyah reactor cavity will be flooded if there is sufficient water on the containment floor to overflow into the cavity. If the contents of the refueling water storage tank are

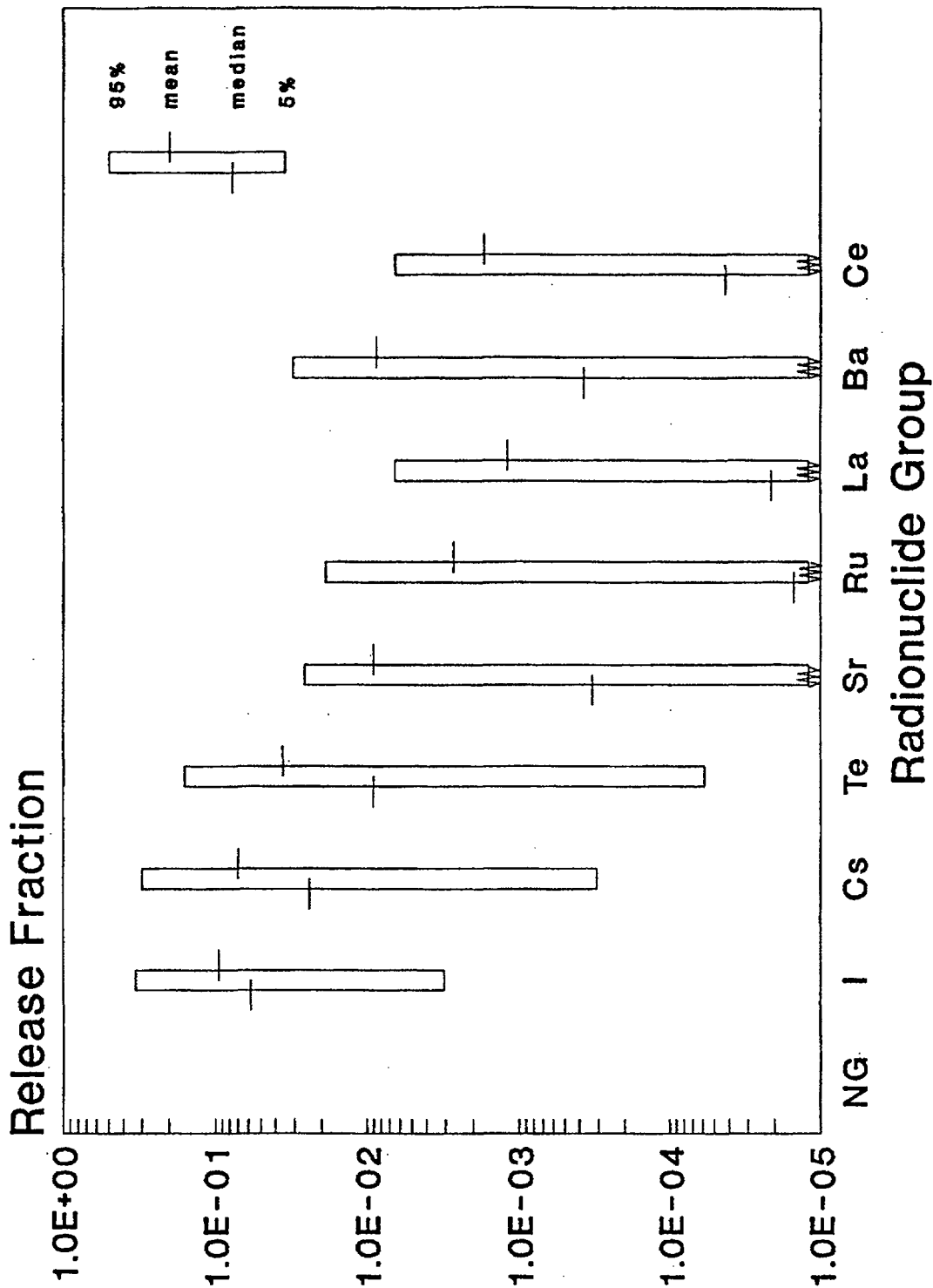

Figure 5.6 Source term distributions for early containment failure at Sequoyah.

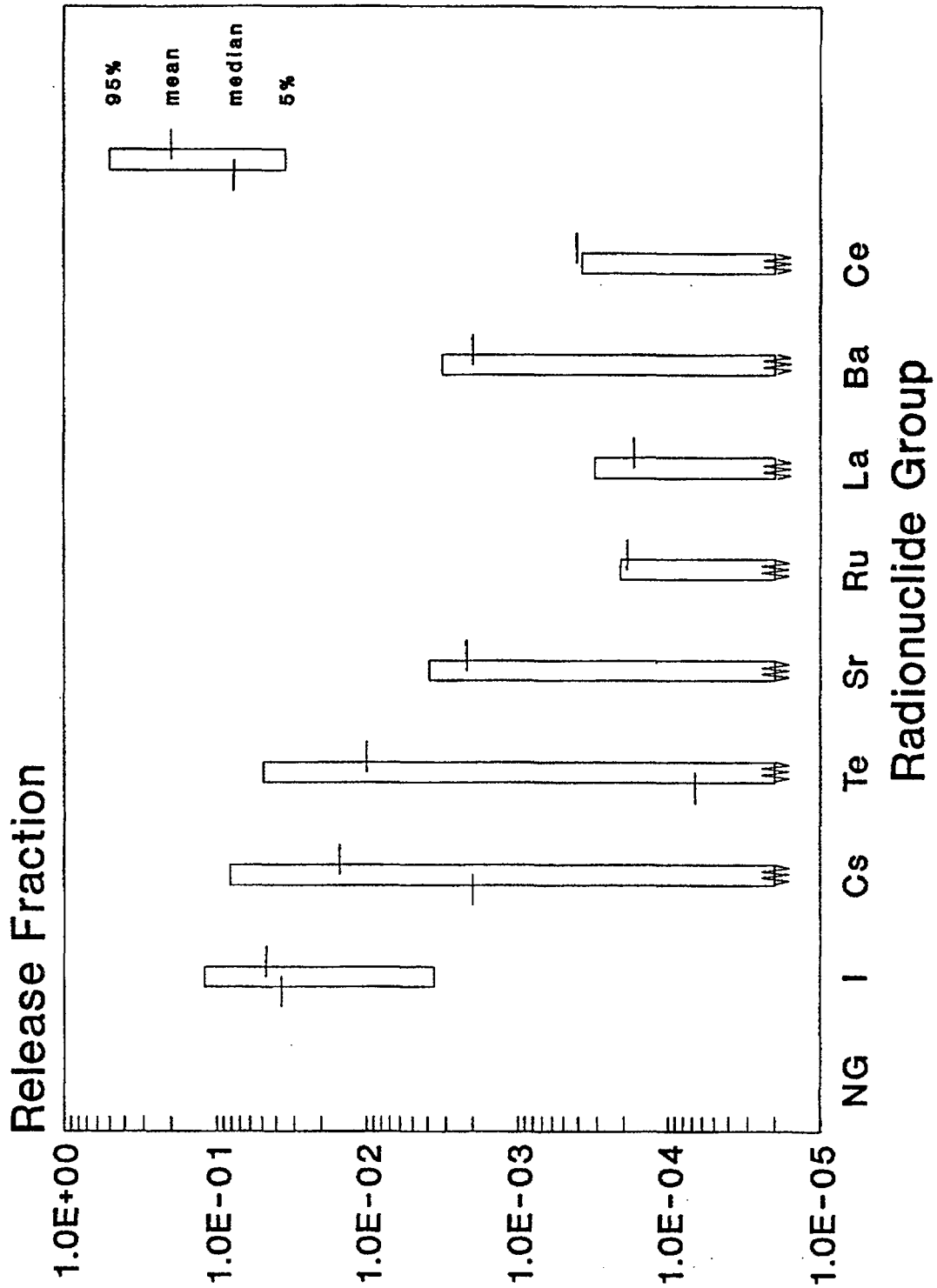

Figure 5.7 Source term distributions for late containment failure at Sequoyah.

discharged into the containment (e.g., by the spray system) and there is substantial ice melting, the water level in the cavity can be as high as 40 feet, extending to the level of the reactor coolant system hot legs. A decontamination factor for the deep water pool was used in the analyses, which ranged from approximately 4 to 9,000 with a median value of approximately 10 for the less volatile radionuclides released ex-vessel. If neither source of water to the containment is available, however, there will be no water in the cavity.

3. Spray System

The Sequoyah containment has a spray system in the upper compartment to condense steam that bypasses the ice beds and for use after the ice has melted. As in the Surry plant, the spray system has the potential to dramatically reduce the airborne concentration of radioactive material if the containment remains intact for an extended period of time.

5.5 Offsite Consequence Results

Figure 5.8 displays the frequency distributions in the form of graphical plots of the complementary cumulative distribution functions (CCDFs) of four offsite consequence measures—early fatalities, latent cancer fatalities, and the 50-mile and entire site region population exposures (in person-rems). These CCDFs include contributions from all source terms associated with reactor accidents caused by internal initiating events. Four CCDFs, namely, the 5th percentile, 50th percentile (median), 95th percentile, and the mean CCDFs, are shown for each consequence measure.

Sequoyah plant-specific and site-specific parameters were used in the consequence analysis for these CCDFs. The plant-specific parameters included source terms and their frequencies, the licensed thermal power (3423 MWt) of the reactor, and the appropriate physical dimensions of the power plant building complex. The site-specific parameters included exclusion area radius (585 meters), meteorological data for 1 full year collected at the site meteorological tower, the site region population distribution based on the 1980 census data, topography (fraction of the area that is land—the remaining fraction is assumed to be water), land use, agricultural practice and productivity, and other economic data for up to 1,000 miles from the Sequoyah plant.

The consequence estimates displayed in these figures have incorporated the benefits of the following protective measures: (1) evacuation of 99.5 percent of the population within the 10-mile plume exposure pathway emergency planning zone (EPZ), (2) early relocation of the remaining population only from the heavily contaminated areas both within and outside the 10-mile EPZ, and (3) decontamination, temporary interdiction, or condemnation of land, property, and foods contaminated above acceptable levels.

The population density within the Sequoyah 10-mile EPZ is about 120 persons per square mile. The average delay time before evacuation (after a warning prior to radionuclide release) from the 10-mile EPZ and average effective evacuation speed used in the analyses were derived from information contained in a utility-sponsored Sequoyah evacuation time estimate study (Ref. 5.5) and the NRC requirements for emergency planning.

The results displayed in Figure 5.8 are discussed in Chapter 11.

5.6 Public Risk Estimates

5.6.1 Results of Public Risk Estimates

A detailed description of the results of the Sequoyah risk is provided in Reference 5.2. For this summary report, results are provided for the following measures of public risk:

- Early fatality risk,
- Latent cancer fatality risk,
- Population dose within 50 miles of the site,
- Population dose within the entire site region,
- Individual early fatality risk in the population within 1 mile of the Sequoyah boundary, and
- Individual latent cancer fatality risk in the population within 10 miles of the Sequoyah site.

The first four of the above measures are commonly used measures in nuclear power plant risk studies. The last two are those used to compare with the NRC safety goals (Ref. 5.6).

The results of Sequoyah risk analysis using the above measures are shown in Figures 5.9 through 5.11. The figures display the variabilities in mean risks estimated from the meteorology-averaged mean values of the consequence measures. The

5. Sequoyah Plant Results

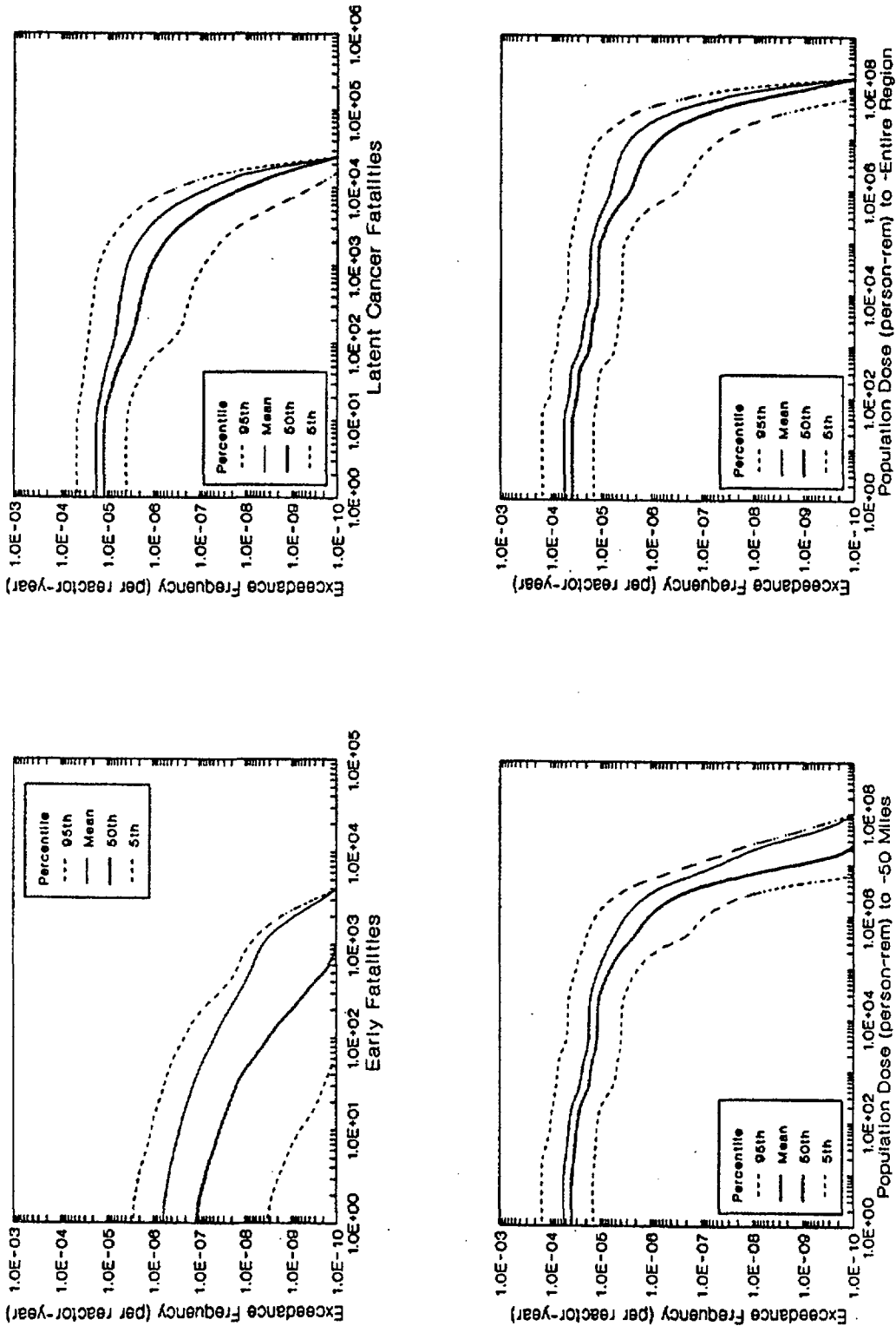

Note: As discussed in Reference 5.3, estimated consequences at frequencies at or below 1E-7 per reactor year should be viewed with caution because of the potential impact of events not studied in the risk analyses.

Figure 5.8 Frequency distributions of offsite consequence measures at Sequoyah (internal initiators).

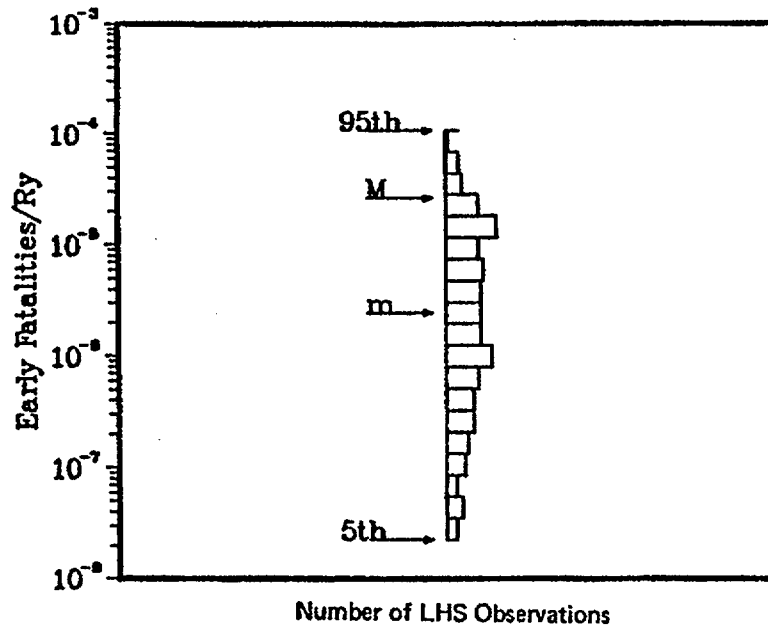

Key: M = mean
 m = median
 th = percentile

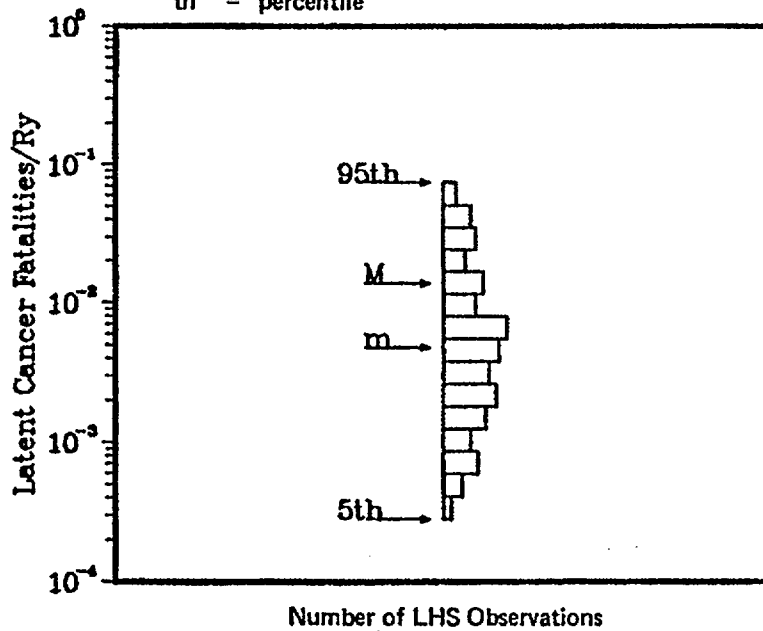

Note: As discussed in Reference 5.3, estimated risks at or below 1E-7 per reactor year should be viewed with caution because of the potential impact of events not studied in the risk analyses.

Figure 5.9 Early and latent cancer fatality risks at Sequoyah (internal initiators).

5. Sequoyah Plant Results

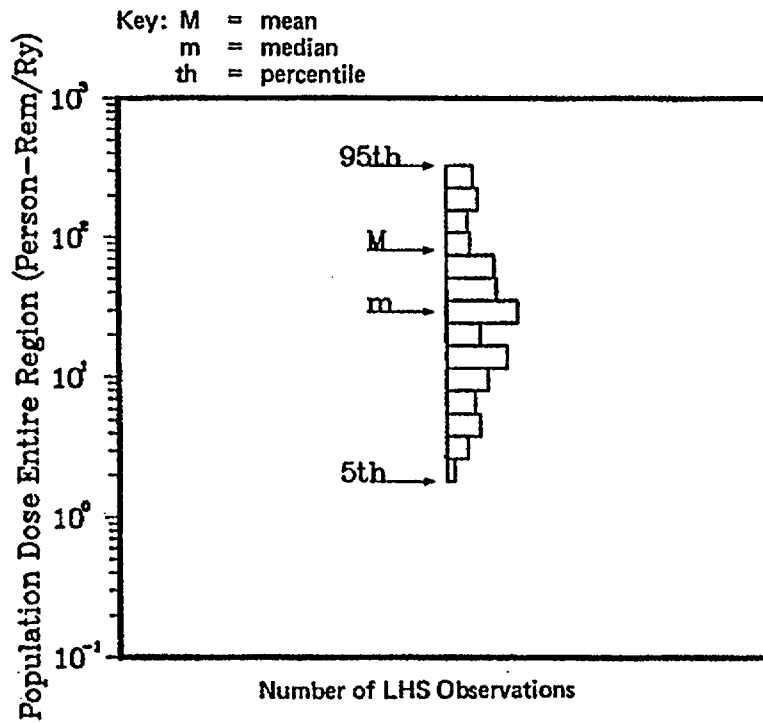
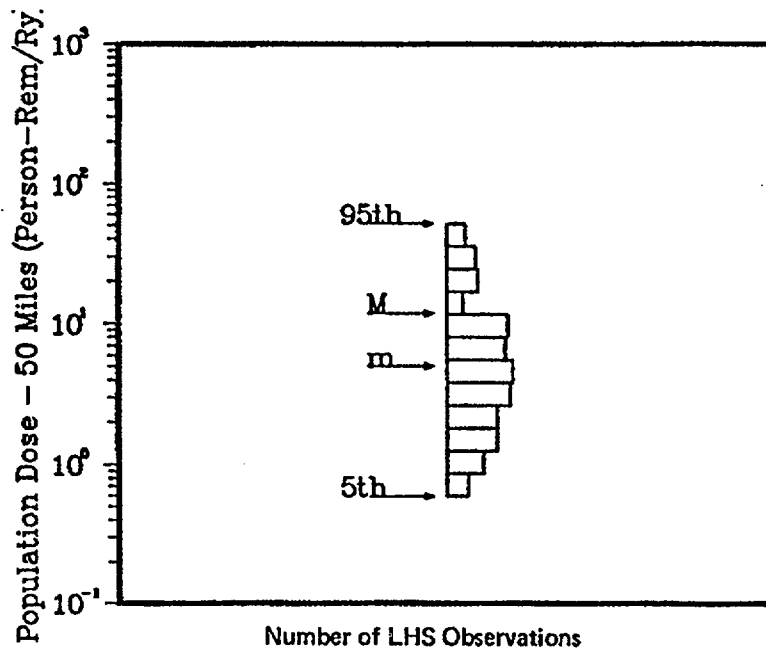

Note: As discussed in Reference 5.3, estimated risks at or below $1E-7$ per reactor year should be viewed with caution because of the potential impact of events not studied in the risk analyses.

Figure 5.10 Population dose risks at Sequoyah (internal initiators).

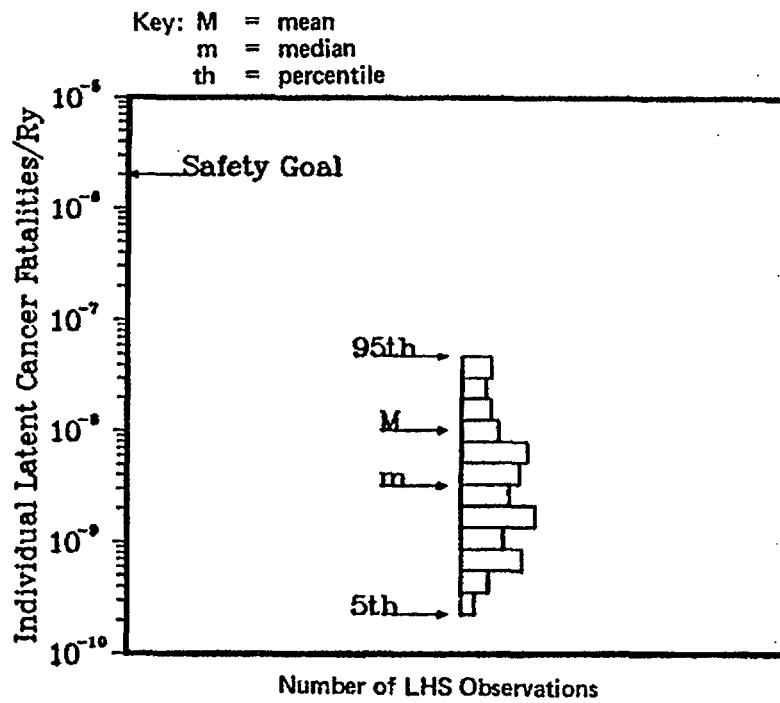
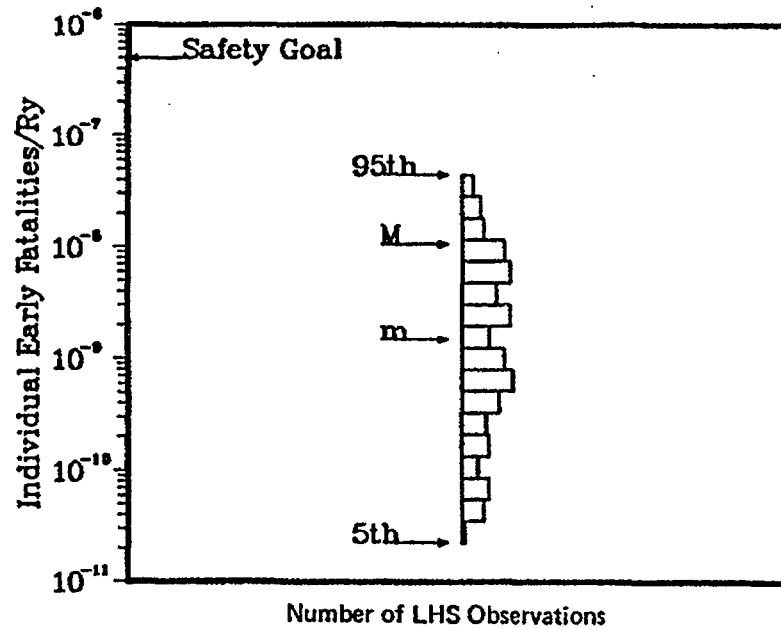

Note: As discussed in Reference 5.3, estimated risks at or below $1E-7$ per reactor year should be viewed with caution because of the potential impact of events not studied in the risk analyses.

Figure 5.11 Individual early and latent cancer fatality risks at Sequoyah (internal initiators).

5. Sequoyah Plant Results

early and latent cancer fatality risks, while quite low in absolute value, are higher than those from the Surry plant analysis (see Chapter 3). Other risk measure estimates are slightly higher than the Surry estimates. The individual early fatality and latent cancer fatality risks are well below the NRC safety goals. Detailed comparisons of results are provided in Chapter 12.

The risk results shown in Figure 5.9 have been analyzed to identify the relative contributions to mean risk of plant damage states and accident progression bins. These results are presented in Figures 5.12 and 5.13. As may be seen, the dominant contributor of early fatality risk is the bypass accident group, and particularly the interfacing-system LOCA (the V sequence); whereas the largest contributions to the latent cancer fatality risk came from the station blackout and bypass accident groups. For early fatality risk, the dominant contributor to risk is from accident sequences where the containment is bypassed, whereas, for latent cancer fatality risk, major accident progression bin contributors are bypass accidents and early containment failures. The accident progression bin involving accidents with no vessel breach appears as a contributor to early and latent cancer fatality risks. This bin possesses risk potential because of early containment failure due to hydrogen events from loss of offsite power in which ac power is recovered and breach is arrested and also from accidents involving steam generator tube rupture in which vessel breach is arrested.

5.6.2 Important Plant Characteristics (Risk)

Sequoyah risk analysis indicates that bypass sequences dominate early fatality risk. Timing is a key factor in this sequence in relation to evacuation. The release characteristics also contribute to the large effect of early fatalities because of the large magnitude of unmitigated source terms and the low energy of the first release. The low energy plume is not lofted over the evacuees but is held low to the ground after release. Another class of accidents that is important to early fatality risk is station blackout. It is the early containment failure (that is, failure of containment at and before vessel breach) associated with this accident class that contributes to early fatality risk.

An interfacing-system LOCA at Sequoyah will discharge into the auxiliary building where decontamination by automatically activated fire sprays is likely. Neither the probability of actuation nor the decontamination factor has been well established. The effects of an interfacing-system LOCA could either be higher or lower than those that have been calculated in this study.

Approximately equal contributions to latent cancer fatality risk come from station blackout and bypass. The bypass sequences contribute because of the large source terms and the bypass of any mitigating systems. The only other major contribution to latent cancer fatality comes from the LOCA sequences, mainly due to containment failures at vessel breach with high (> 200 psia) reactor coolant system pressure.

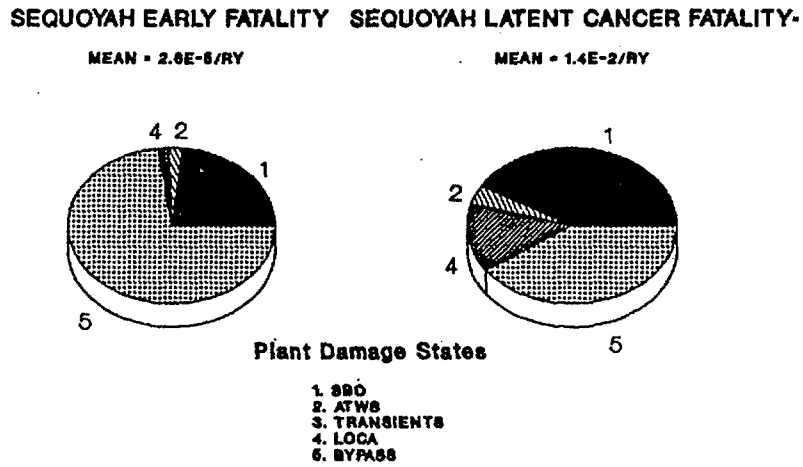

Figure 5.12 Major contributors (plant damage states) to mean early and latent cancer fatality risks at Sequoyah (internal initiators).

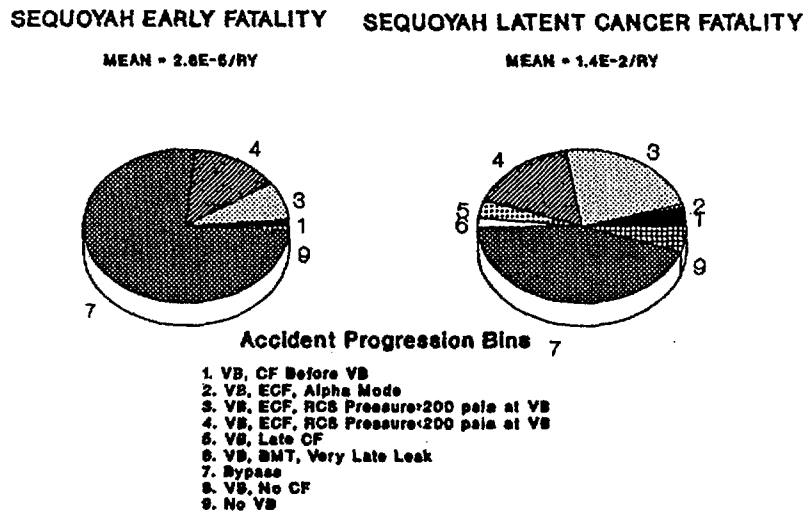

Figure 5.13 Major contributors (accident progression bins) to mean early and latent cancer fatality risks at Sequoyah (internal initiators).

REFERENCES FOR CHAPTER 5

- 5.1 R. C. Bertucio and S. R. Brown, "Analysis of Core Damage Frequency: Sequoyah Unit 1," Sandia National Laboratories, NUREG/CR-4550, Vol. 5, Revision 1, SAND86-2084, April 1990.
- 5.2 J. J. Gregory et al., "Evaluation of Severe Accident Risks: Sequoyah Unit 1," Sandia National Laboratories, NUREG/CR-4551, Vol. 5, Revision 1, SAND86-1309, December 1990.
- 5.3 H. J. C. Kouts et al., "Special Committee Review of the Nuclear Regulatory Commission's Severe Accident Risks Report (NUREG-1150)," NUREG-1420, August 1990.
- 5.4 T. A. Wheeler et al., "Analysis of Core Damage Frequency from Internal Events: Expert Judgment Elicitation," Sandia National Laboratories, NUREG/CR-4550, Vol. 2, SAND86-2084, April 1989.
- 5.5 Tennessee Department of Transportation, "Evacuation Time Estimates with the Plume Exposure Pathway Emergency Planning Zone," prepared for Sequoyah Nuclear Plant, June 1987.
- 5.6 USNRC, "Safety Goals for the Operation of Nuclear Power Plants; Policy Statement," *Federal Register*, Vol. 51, p. 30028, August 21, 1986.

6. GRAND GULF PLANT RESULTS

6.1 Summary Design Information

The Grand Gulf Nuclear Station is a General Electric boiling water reactor (BWR-6) unit of 1250 MWe capacity housed in a Mark III containment. Grand Gulf Unit 1, constructed by Bechtel Corporation, began commercial operation in July 1985 and is operated by Entergy Operations. Some important design features of the Grand Gulf plant are described in Table 6.1. A general plant schematic is provided in Figure 6.1.

This chapter provides a summary of the results obtained in the detailed risk analyses underlying this report (Refs. 6.1 and 6.2). A discussion of perspectives with respect to these results is provided in Chapters 8 through 12.

6.2 Core Damage Frequency Estimates

6.2.1 Summary of Core Damage Frequency Estimates

The core damage frequency and risk analyses performed for this study considered accidents initiated only by internal events (Ref. 6.1). The core damage frequency results obtained are provided in tabular form in Table 6.2 and in graphical form, displayed as a histogram, in Figure 6.2. (Section 2.2.2 discusses histogram development.) This study calculated a total median core damage frequency from internal events of $1.2E-6$ per year.

The Grand Gulf plant was previously analyzed in the Reactor Safety Study Methodology Applications Program (RSSMAP) (Ref. 6.3). A point estimate core damage frequency of $3.6E-5$ from internal events was calculated in that study. A point estimate core damage frequency of $2.1E-6$ was calculated in this analysis for purposes of comparison. A point estimate is calculated from the sum of all the cut-set frequencies, where each of the cut-set frequencies is the product of the point estimates (usually means) of the events in the cut sets.

6.2.1.1 Internally Initiated Accident Sequences

A detailed description of accident sequences important at the Grand Gulf plant is provided in Reference 6.1. For this report, the accident sequences described in that reference have been di-

vided into two summary plant damage states. These are:

- Station blackout, and
- Anticipated transients without scram (ATWS).

The relative contributions of these groups to mean internal-event core damage frequency at Grand Gulf are shown in Figure 6.3. It may be seen that station blackout accident sequences as a class are the largest contributors to core damage frequency. It should be noted that the plant configuration as analyzed does not reflect the implementation of the station blackout rule.

Within the general class of station blackout accidents, the more probable combinations of failures leading to core damage are:

- Loss of offsite power occurs followed by the successful cycling of the safety relief valves (SRVs). Onsite ac power fails because all three diesel generators fail to start and run as a result of either hardware or common-cause faults. The loss of all ac power (i.e., station blackout) results in the loss of all core cooling systems (except for the reactor core isolation cooling (RCIC) system) and all containment heat removal systems. The RCIC system, which is ac independent, independently fails to start and run. All core cooling is lost, and core damage occurs in approximately 1 hour after offsite power is lost.
- Station blackout accident that is similar to the one described above except that one SRV fails to reclose and sticks open. Core damage occurs in approximately 1 hour after offsite power is lost.

In addition to these two short-term accident scenarios, this study also considered long-term station blackout accidents. In these accidents, loss of offsite power occurs and all three diesel generators fail to start or run. The safety relief valves cycle successfully and RCIC starts and maintains proper coolant level within the reactor vessel. However, ac power is not restored in these long-term scenarios, and RCIC eventually fails because of high turbine exhaust pressure, battery depletion, or other long-term effects. Core damage occurs approximately 12 hours after offsite power is lost.

6. Grand Gulf Plant Results

Table 6.1 Summary of design features: Grand Gulf Unit 1.

-
- | | |
|-------------------------------|--|
| 1. Coolant Injection Systems | <ul style="list-style-type: none">a. High-pressure core spray (HPCS) system provides coolant to reactor vessel during accidents in which system pressure remains high or low, with 1 train and 1 MDP.*b. Reactor core isolation cooling system provides coolant to the reactor vessel during accidents in which system pressure remains high, with 1 train and 1 TDP.*c. Low-pressure core spray system provides coolant to the reactor vessel during accidents in which vessel pressure is low, with 1 train and 1 MDP.*d. Low-pressure coolant injection system provides coolant to the reactor vessel during accidents in which vessel pressure is low, with 3 trains and 3 pumps.e. Standby service water crosstie system provides coolant makeup source to the reactor vessel during accidents in which normal sources of emergency injection have failed, with 1 train and 1 pump (for crosstie).f. Firewater system is used as a last resort source of low-pressure coolant injection to the reactor vessel, with 3 trains, 1 MDP,* 2 diesel-driven pumps.g. Control rod drive system provides backup source of high-pressure injection, with 2 pumps/238 gpm (total)/1103 psia.h. Automatic depressurization system (ADS) depressurizes the reactor vessel to a pressure at which the low-pressure injection systems can inject coolant to the reactor vessel, with 8 relief valves/capacity of 900,000 lb/hr. In addition, there are 12 non-ADS relief valves.i. Condensate system used as a backup injection source. |
| <hr/> | |
| 2. Heat Removal Systems | <ul style="list-style-type: none">a. Residual heat removal/suppression pool cooling system removes decay heat from the suppression pool during accidents, with 2 trains and 2 pumps.b. Residual heat removal/shutdown cooling system removes decay heat during accidents in which reactor vessel integrity is maintained and reactor is at low pressure, with 2 trains and 2 pumps.c. Residual heat removal/containment spray system suppresses pressure in the containment during accidents, with 2 trains and 2 pumps. |
| <hr/> | |
| 3. Reactivity Control Systems | <ul style="list-style-type: none">a. Control rods.b. Standby liquid control system, with 2 parallel positive displacement pumps rated at 43 gpm per pump. |
-

*TDP - Turbine-Driven Pump
MDP - Motor-Driven Pump

Table 6.1 (Continued)

| | |
|--------------------------|--|
| 4. Key Support Systems | <ul style="list-style-type: none"> a. dc power with 12-hour station batteries. b. Emergency ac power, with 2 diesel generators and third diesel generator dedicated to HPCS but with crossties. c. Suppression pool makeup system provides water from the upper containment pool to the suppression pool following a LOCA. d. Standby service water provides cooling water to safety systems and components. |
| 5. Containment Structure | <ul style="list-style-type: none"> a. BWR Mark III. b. 1.67 million cubic feet. c. 15 psig design pressure. |
| 6. Containment Systems | <ul style="list-style-type: none"> a. Containment venting is used when suppression pool cooling and containment sprays have failed to reduce primary containment pressure. b. Hydrogen igniter system prevents the buildup of large quantities of hydrogen inside the containment during accident conditions. |

Within the general class of ATWS accidents, the most probable combination of failures leading to core damage is:

- Transient initiating event occurs followed by a failure to trip the reactor because of mechanical faults in the reactor protection system (RPS). The standby liquid control system (SLCS) is not actuated and the high-pressure core spray (HPCS) system fails to start and run because of random hardware faults. The reactor is not depressurized and therefore the low-pressure core cooling system cannot inject. All core cooling is lost; core damage occurs in approximately 20 to 30 minutes after the transient initiating event occurs.

6.2.2 Important Plant Characteristics (Core Damage Frequency)

Characteristics of the Grand Gulf plant design and operation that have been found to be important in the analysis of core damage frequency include:

1. Firewater System as Source of Coolant Makeup

The firewater system as a core coolant injection system can be used as a backup (last re-

sort) source of low-pressure coolant injection to the reactor vessel. The system has two diesel-driven pumps, making it operational under station blackout conditions as long as dc power is available. The potential use of this system is estimated to reduce the total core damage frequency by approximately a factor of 1.5.

The reason for the relatively small impact on the total core damage frequency is twofold. The firewater system is a low-pressure system; the reactor pressure must be maintained below approximately 125 psia for firewater to be able to inject. If an accident occurs in which core cooling is immediately lost, the core becomes uncovered in less time than that required to align and activate the firewater system. If core cooling is provided and then lost in the long term (e.g., at approximately greater than 4 hours after the start of the accident), firewater can provide sufficient makeup to prevent core damage. However, the dominant sequences at Grand Gulf are accidents where core cooling is lost immediately.

6. Grand Gulf Plant Results

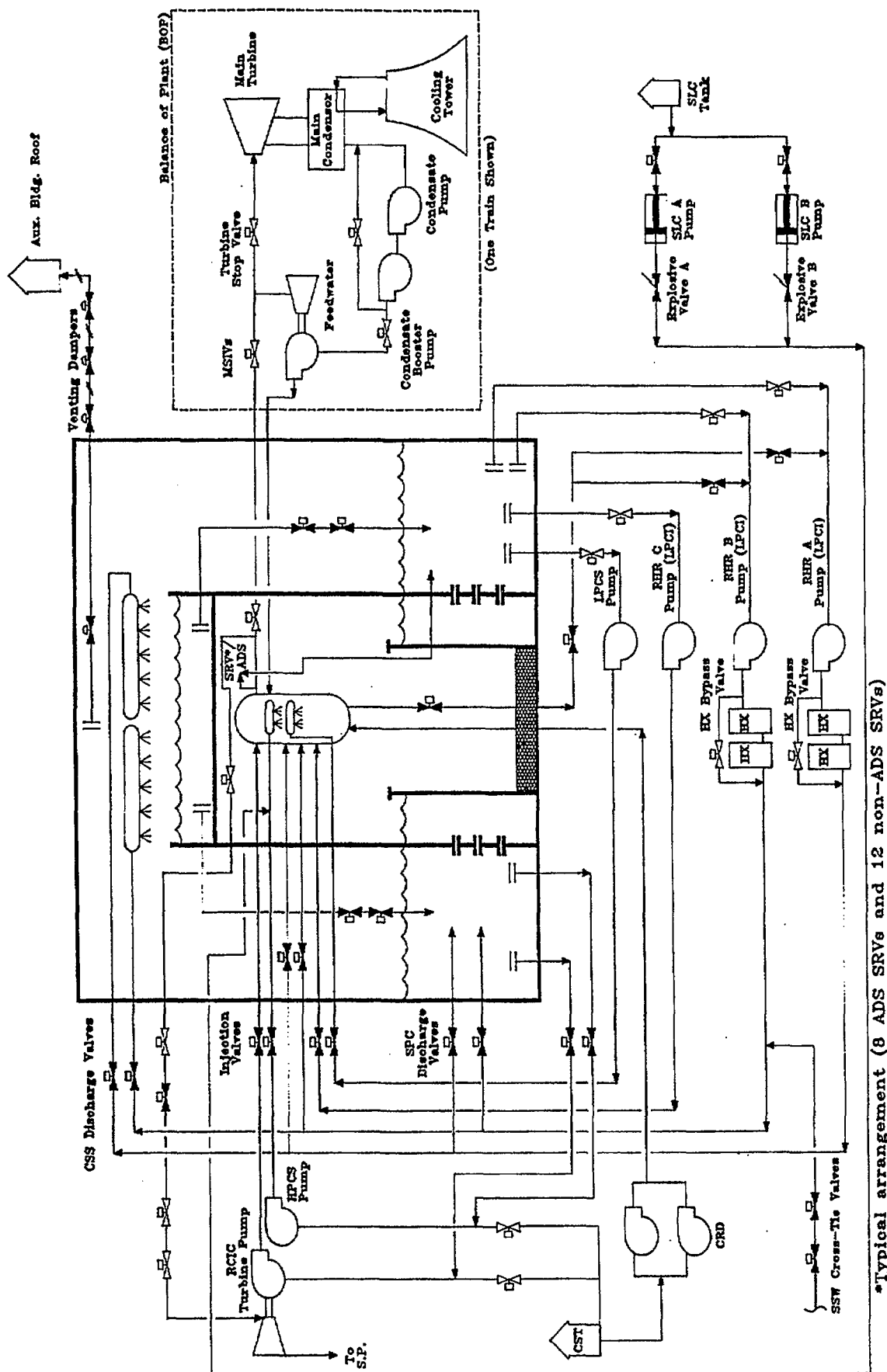
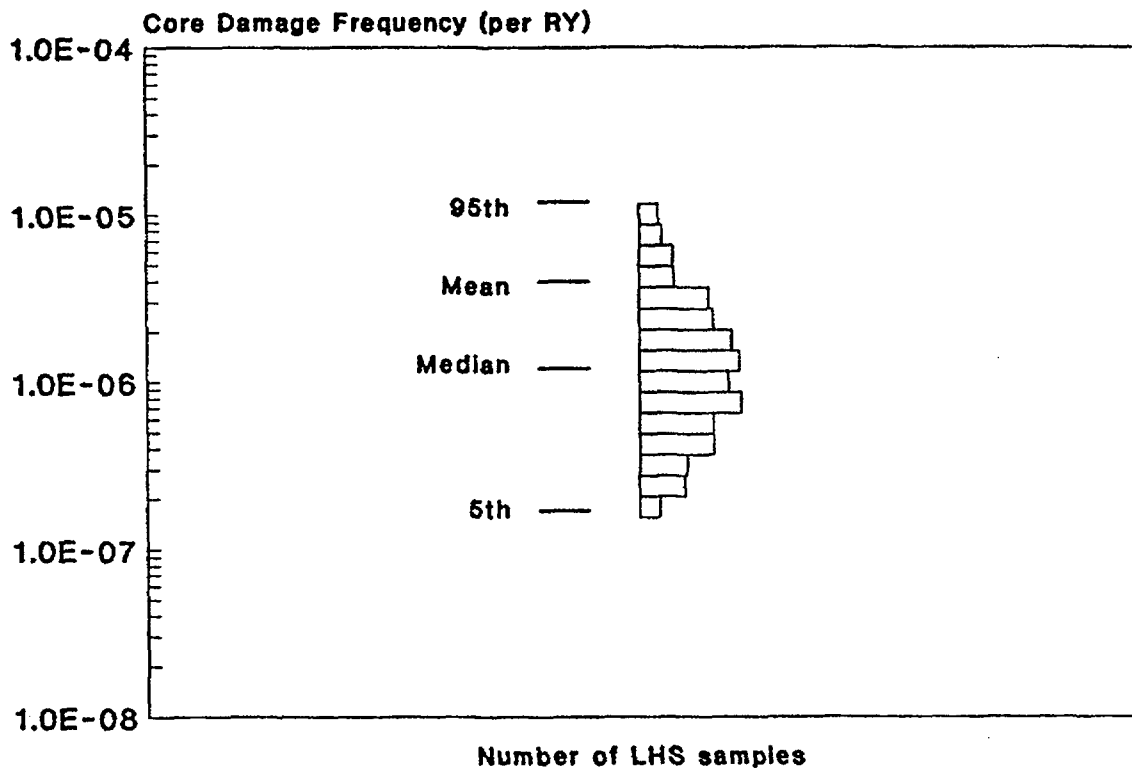

Figure 6.1 Grand Gulf plant schematic.

Table 6.2 Summary of core damage frequency results: Grand Gulf.*

| | 5% | Median | Mean | 95% |
|------------------|---------|--------|--------|--------|
| Internal Events | 1.7E-7 | 1.2E-6 | 4.0E-6 | 1.2E-5 |
| ATWS | 8.5E-10 | 1.9E-8 | 1.1E-7 | 5.1E-7 |
| Station Blackout | 1.3E-7 | 1.1E-6 | 3.9E-6 | 1.1E-5 |

*As discussed in Reference 6.4, core damage frequencies below 1E-5 per reactor year should be viewed with caution because of the remaining uncertainties in PRA (e.g., events not considered).



Note: As discussed in Reference 6.4, core damage frequencies below 1E-5 per reactor year should be viewed with caution because of the remaining uncertainties in PRA (e.g., events not considered).

Figure 6.2 Internal core damage frequency results at Grand Gulf.

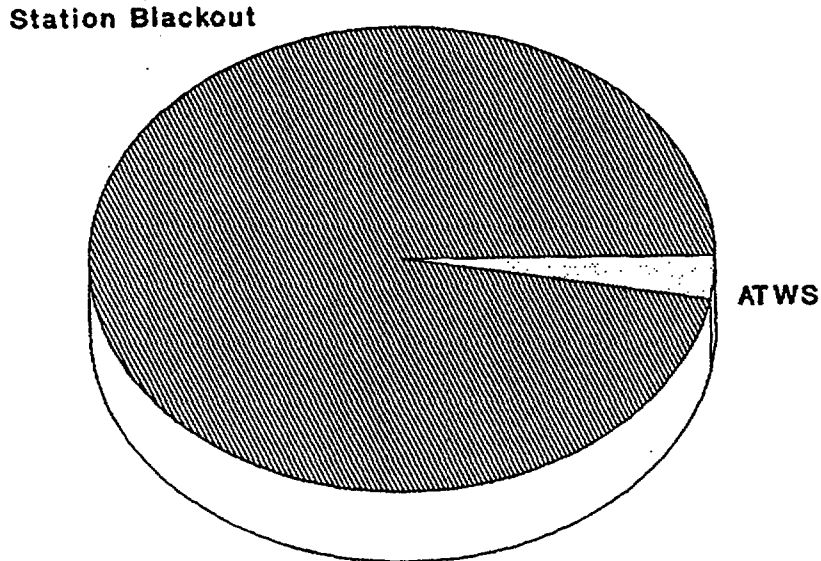

Total Mean Core Damage Frequency: 4.0E-6

Figure 6.3 Contributors to mean core damage frequency from internal events at Grand Gulf.

2. High-Pressure Core Spray (HPCS) System

The HPCS system consists of a single train with motor-operated valves and a motor-driven pump and provides coolant to the reactor vessel during accidents in which pressure is either high or low. The bearings and seals of the HPCS pump are cooled by the pumped fluid. If the temperature of this water exceeds design limits, the potential exists for the HPCS pump to fail. The bearings are designed to operate for no more than 24 hours at a temperature of 350°F. The peak temperature achieved in any of the accidents analyzed is approximately 325°F. Even if the seals were to experience some leakage, the resultant HPCS room environment would not adversely affect the operability of the pump. The availability of an HPCS system with such design characteristics is estimated to reduce the core damage frequency by approximately a factor of 7. The HPCS is powered by a dedicated diesel generator when required so that this system is truly an independent system.

3. Capability of Pumps to Operate with Saturated Water

The emergency core cooling pumps that depend on the pressure-suppression pool as their water source during accident conditions have been designed to pump saturated water. Thus, if the pool becomes saturated because of containment venting or containment failure, the core cooling systems are not lost but can continue to cool the reactor core.

4. Redundancy and Diversity of Water Supply Systems

At Grand Gulf, there are many redundant and diverse systems to provide water to the reactor vessel. They include:

HPCS with 1 pump;

Reactor core isolation cooling (RCIC) with 1 pump;

Control rod drive (CRD) with 2 pumps (both are required for core cooling);

Condensate with 3 pumps;

Low-pressure core spray (LPCS) with 1 pump;

Low-pressure coolant injection (LPCI) with 3 pumps;

Standby service water (SSW) crosstie with 1 pump; and

Firewater system with 3 pumps.

Because of the redundancy of systems for LOCAs and transients, core cooling loss as a result of independent random failures is of low probability. However, in a station blackout, except for RCIC and firewater, the core cooling systems are lost with a probability of unity because they require ac power.

5. Redundancy and Diversity of Heat Removal Systems

At Grand Gulf there are several diverse means for heat removal. These systems are:

Main steam/feedwater system with 3 trains;

Suppression pool cooling mode of residual heat removal (RHR) with 2 trains;

Shutdown cooling mode of RHR with 2 trains;

Containment spray system mode of RHR with 2 trains; and

Containment venting with 1 train.

Although the various modes of RHR have common equipment (e.g., pumps), there is still enough redundancy and diversity that, for non-station-blackout accidents, independent random failures again are small contributors to the core damage frequency.

6. Automatic and Manual Depressurization System

The automatic depressurization system (ADS) is designed to depressurize the reactor vessel to a pressure at which the low-pressure injection systems can inject coolant to the reactor vessel. The ADS consists of eight safety relief valves capable of being manually opened. The operator may manually initiate the ADS or may depressurize the reactor vessel, using the 12 relief valves that are not connected to the ADS logic. The ADS valves are located inside the containment.

6.2.3 Important Operator Actions

The emergency operating procedures (EOPs) at Grand Gulf direct the operator to perform certain actions depending on the plant conditions or symptoms (e.g., reactor vessel level below the top of active fuel). Different accident sequences can have similar symptoms and therefore the same "recovery" actions. Operator actions that are important include the following:

- Actuate core cooling

In an accident where feedwater is lost (which includes condensate), the reactor water level starts to decrease. When Level 2 (-41.6 inches) is reached, high-pressure core spray (HPCS) and reactor core isolation cooling (RCIC) should be automatically actuated. If Level 1 (-150.3 inches) is reached, the ADS should occur with automatic actuation of the low-pressure core spray (LPCS) and low-pressure coolant injection (LPCI). If the reactor level sensors are miscalibrated, these systems will not automatically actuate. The operator has many other indications to determine both the reactor water level and the fact that core coolant makeup is not occurring. Manual actuation of these systems is required if such failures occur in order to prevent core damage.

- Establish containment heat removal

Besides core cooling, the operator must also establish containment heat removal (CHR). If an accident occurs, the EOPs direct the operator to initiate the suppression pool cooling mode of RHR when the suppression temperature reaches 95°F. The operator closes the LPCI valves and the heat exchanger bypass valves and opens the suppression pool discharge valves. He also ensures that the proper service water system train is operating. With suppression pool cooling (SPC) functioning, CHR is being performed. If system faults preclude the use of SPC, the operator has other means to provide CHR. He can actuate other modes of RHR such as shutdown cooling or containment spray, or the operator can vent the containment to remove the energy.

- Establish room cooling through natural circulation

The heating, ventilating, and air conditioning (HVAC) system provides room cooling support to a variety of systems. If HVAC is lost, design limits can be exceeded and equipment

6. Grand Gulf Plant Results

(i.e., pumps) can fail. If these conditions occur, the operator can open doors to certain rooms and establish a natural circulation/ventilation that prevents the room temperature from exceeding the design limits of the equipment.

For station blackout accidents, there are certain actions that can be performed by the operating crew as follows:

- Crosstie division 1 or 2 loads to HPCS diesel generator

In a station blackout where the HPCS diesel generator is available, the operator can choose to crosstie this diesel to one of the other divisions. The operator might choose this option when (1) the HPCS system fails and core cooling is required, or (2) in the long term (e.g., longer than 8 hours) containment heat removal is required to prevent containment failure. If the operator chooses to crosstie, the operator must shed all the loads from the HPCS diesel and then open and close certain breakers. He can then load certain systems from either division 1 or from division 2.

- Align firewater

In an accident, particularly station blackout, where core cooling was initially available (for approximately 4 hours) and then lost, the firewater system can provide adequate core cooling. The operator must align the firewater hoses to the proper injection lines (described in the procedure) and then open the injection valves.

- Depressurize reactor via RCIC steam line

In a station blackout, the diesel generators have failed and only dc power is available (in certain sequences). If core cooling is being provided with firewater, then the reactor must remain at low pressure, which requires that at least one safety relief valve (SRV) must remain open. For the SRV to remain open, dc power is required. However, without the diesel generator recharging the battery, the battery will eventually deplete, the SRV will close, and the reactor will repressurize, which causes the loss of the firewater. The operator can maintain the reactor pressure low by opening the valves on the RCIC steam line. This provides a vent path from the reactor to the suppression pool.

- Recovering ac power

Station blackout is caused by the loss of all ac power, both offsite and onsite power. Restoring offsite power or repairing the diesel generators was included in the analysis. The quantification of these human failure events was derived from historical data (i.e., actual time required to perform these repairs) and not by performing human reliability analysis on these events.

Transients where reactor trip does not occur (i.e., ATWS) involve accident sequences where the phenomena are more complex. The operator actions were evaluated in more detail (Ref. 6.5) than for the regular transient-initiated accident. These actions include the following:

- Manual scram

A transient occurs that demands the reactor to be tripped, but the reactor protection system (RPS) fails because of electrical faults. The operator can then manually trip the reactor by first rotating the collar on proper scram buttons and then depressing the buttons, or he can put the reactor mode switch in the "shutdown" position.

- Insert rods manually

If the electrical faults fail both the RPS and the manual trip, the operator can manually insert the control rods one a time.

- Actuate standby liquid control (SLC) system

With the reactor not tripped, reactor power remains high; the reactor core is not at decay heat levels. This can present problems since the containment heat removal systems are only designed to decay heat removal capacity. However, the SLC system (manually actuated) injects sodium pentaborate that reduces reactor power to decay heat levels. The EOPs direct the operator to actuate SLC if the reactor power is above 4 percent and before the suppression pool temperature reaches 110°F. The operator obtains the SLC keys (one per pump) from the shift supervisor's desk, inserts the keys into the switches, and turns both to the "on" position.

- Inhibit automatic depressurization system (ADS)

In an ATWS condition, the operator is directed to inhibit the ADS if he has actuated

SLC. The operator must put both ADS switches (key locked) in the inhibit mode.

- Manually depressurize reactor

If HPCS fails, inadequate high-pressure core cooling occurs. When Level 1 is reached, ADS will not occur because the ADS was inhibited, and the operator must manually depressurize so that low-pressure core cooling can inject. The operator can either press the ADS button (which overrides the inhibit) or manually open one SRV at a time.

6.2.4 Important Individual Events and Uncertainties (Core Damage Frequency)

As discussed in Chapter 2, the process of developing a probabilistic model of a nuclear power plant involves the combination of many individual events (initiators, hardware failures, operator errors, etc.) into accident sequences and eventually into an estimate of the total frequency of core damage. After development, such a model can also be used to assess the importance of the individual events. The detailed studies underlying this report have been analyzed using several event importance measures. The results of the analyses using two measures, "risk reduction" and "uncertainty" importance, are summarized below.

- Risk (core damage frequency) reduction importance measure (internal events)

The risk-reduction importance measure is used to assess the change in core damage frequency as a result of setting the probability of an individual event to zero. Using this measure, the following individual events were found to cause the greatest reduction in core damage frequency if their probabilities were set to zero.

- Loss of offsite power initiating event. The core damage frequency would be reduced by approximately 92 percent.
- Failure to restore offsite power in 1 hour. The core damage frequency would be reduced by approximately 70 percent.
- Failure of the RCIC turbine-driven pump to run. The core damage frequency would be reduced by approximately 48 percent.

- Failure to repair hardware faults of diesel generator in 1 hour. The core damage frequency would be reduced by approximately 46 percent.

- Failure of a diesel generator to start. The core damage frequency would be reduced by approximately 23 to 32 percent, depending on the diesel generator.

- Common-cause failure of the vital batteries. The core damage frequency would be reduced by approximately 20 percent.

- Uncertainty importance measure (internal events)

A second importance measure used to evaluate the core damage frequency analysis results is the uncertainty importance measure. For this measure, the relative contribution of the uncertainty of individual events to the uncertainty in total core damage frequency is calculated. Using this measure, the following events were found to be most important:

- Loss of offsite power;
- Failure of the diesel generators to run, given start;
- Individual and common-cause failure of the diesel generators to start;
- Standby service water motor-operated valves (MOVs) fail to open; and
- High-pressure core spray and RCIC MOVs fail to function.

6.3 Containment Performance Analysis

6.3.1 Results of Containment Performance Analysis

The Grand Gulf pressure-suppression containment design is of the Mark III type in which the reactor vessel, reactor coolant circulating loops, and other branch connections to the reactor coolant system are housed within the drywell structure. The drywell structure in turn is completely contained within an outer containment structure with the two volumes communicating through the water-filled vapor suppression pool. The outer containment building is a steel-lined reinforced concrete structure with a volume of 1.67 million cubic feet that is designed for a peak pressure of 15 psig resulting from a reactor coolant system

6. Grand Gulf Plant Results

loss-of-coolant accident. For this same design basis accident, the inner concrete drywell structure is designed for a peak pressure of 30 psig. The mean failure pressure for Grand Gulf's containment structure has been estimated to be 55 psig. This estimated containment failure pressure for Grand Gulf is much lower than the Peach Bottom Mark I estimated failure pressure of 148 psig; however, Grand Gulf's free volume is several times larger. The availability of Grand Gulf's large volume removed the design basis need to inert the containment against failure from hydrogen combustion following design basis accidents; however, subsequent severe accident considerations after the TMI accident resulted in the installation of hydrogen igniters. For the severe accident sequences developed in this analysis, hydrogen combustion remains the major threat to Grand Gulf's containment integrity (in the station blackout accidents dominating the frequency of core damage, igniters are not operable). Similar to other containment design analyses, the estimate of where and when Grand Gulf's containment system will fail relied heavily on the use of expert judgment to interpret the limited data available.

The potential for early containment and/or drywell failure for Grand Gulf as compared to Peach Bottom's Mark I suppression-type containment involves significantly different considerations. Of particular significance with regard to the potential for large radioactive releases from Grand Gulf is the prediction of the combined probabilities of simultaneous early containment and drywell failures, which in turn produce a direct radioactive release path to the environment. The results of these analyses for Grand Gulf are shown in Figures 6.4 and 6.5. Figure 6.4 displays information in which the eight conditional probabilities of containment-related accident progression bins; e.g., VB-early CF-no SPB, are presented for each of four plant damage states, e.g., ATWS. This information indicates that, on a plant damage state frequency-weighted average* for internally initiated events, there are mean conditional probabilities of (1) 0.23 that the integrity of the drywell and the outer containment will be sufficiently affected that substantial bypass of the suppression pool will occur; (2) 0.24 for early containment failure with no bypass of the suppression pool pathway from the drywell; (3) 0.12 for late containment failure with pool bypass; (4) 0.23 for late containment failure

*Each value in the column in Figure 6.4 labeled "All" is a frequency-weighted average obtained by summing the products of individual accident progression bin conditional probabilities for each plant damage state and the ratio of the frequency of that plant damage state to the total core damage frequency.

but no pool bypass; and (5) 0.09 for no containment failure.

Further examination of these data, broken down on the basis of the timing of reactor vessel breach and the nature of the containment threat, indicate: (1) prior to reactor vessel breach, hydrogen combustion and slow steam overpressurization effects lead to frequency-weighted mean conditional probabilities of containment failure of 0.20 and 0.05, respectively; (2) at reactor vessel breach, hydrogen combustion effects lead to a 0.24 conditional mean probability of containment failure; (3) prior to reactor vessel breach, hydrogen combustion effects lead to 0.12 conditional mean probability of drywell failure; (4) at reactor vessel breach, steam explosion and direct containment heating effects can lead to pedestal failures and a 0.16 conditional mean probability of drywell failure from both pedestal and overpressure effects; and (5) dynamic loads from hydrogen detonations have a small effect on the structural integrity of either the containment or the drywell.

Figure 6.5 further displays plots of Grand Gulf's conditional probability distribution for each plant damage state, thereby providing the estimated range of uncertainties in the outer containment failure predictions. The important conclusions that can be drawn from the information are (1) there is a relatively high mean conditional probability of early containment failure with a large bypass of the suppression pool's scrubbing effects, i.e., 0.23; (2) there is a high mean probability of early containment failure, i.e., 0.48; and (3) the principal threat to the combined efficacy of the Mark III containment and drywell is hydrogen combustion effects.

Additional discussions on containment performance (for all studied plants) are provided in Chapter 9.

6.3.2 Important Plant Characteristics (Containment Performance)

Characteristics of the Grand Gulf design and operation that are important during core damage accidents include:

1. Drywell-Wetwell Configuration

With the reactor vessel located inside the drywell, which in turn is completely surrounded by the outer containment building, there needs to be a combination of failures in both structures to provide a direct release path to the environment that bypasses the suppression pool, e.g., hydrogen combustion

**SUMMARY
ACCIDENT
PROGRESSION
BIN GROUP**

**SUMMARY PDS GROUP
(Mean Core Damage Frequency)**

| | STSB (3.85E-06) | LTSB (1.04E-07) | ATWS (1.12E-07) | Transients (1.87E-08) | All (4.09E-06) |
|-----------------------------------|--------------------|--------------------|--------------------|--------------------------|-------------------|
| VB, early CF, early SPB, no CS | 0.168 | 0.292 | 0.006 | 0.011 | 0.158 |
| VB, early CF, early SPB, CS | 0.031 | 0.017 | 0.237 | 0.202 | 0.049 |
| VB, early CF, late SPB | 0.006 | 0.005 | 0.003 | 0.003 | 0.007 |
| VB, early CF, no SPB | 0.182 | 0.531 | 0.505 | 0.331 | 0.218 |
| VB, late CF | 0.308 | 0.129 | 0.074 | 0.232 | 0.284 |
| VB, venting | 0.032 | 0.003 | 0.109 | 0.075 | 0.038 |
| VB, No CF | 0.053 | 0.003 | 0.036 | 0.092 | 0.050 |
| No VB | 0.201 | 0.015 | 0.025 | 0.050 | 0.180 |

CF = Containment Failure
CS = Containment Sprays
CV = Containment Venting
SPB = Suppression Pool Bypass
VB = Vessel Breach

Figure 6.4 Conditional probability of accident progression bins at Grand Gulf.

impairing the function of both the drywell and containment.

2. Containment Volume

The Grand Gulf containment volume is much larger than that of a Mark I containment and as such can accommodate significant quanti-

ties of noncombustible gases before failure even though its estimated failure pressure is less than half that of a Mark I containment. Its low design pressure, however, makes it susceptible to failure from hydrogen combustion effects in those cases where the igniters are not working.

6. Grand Gulf Plant Results

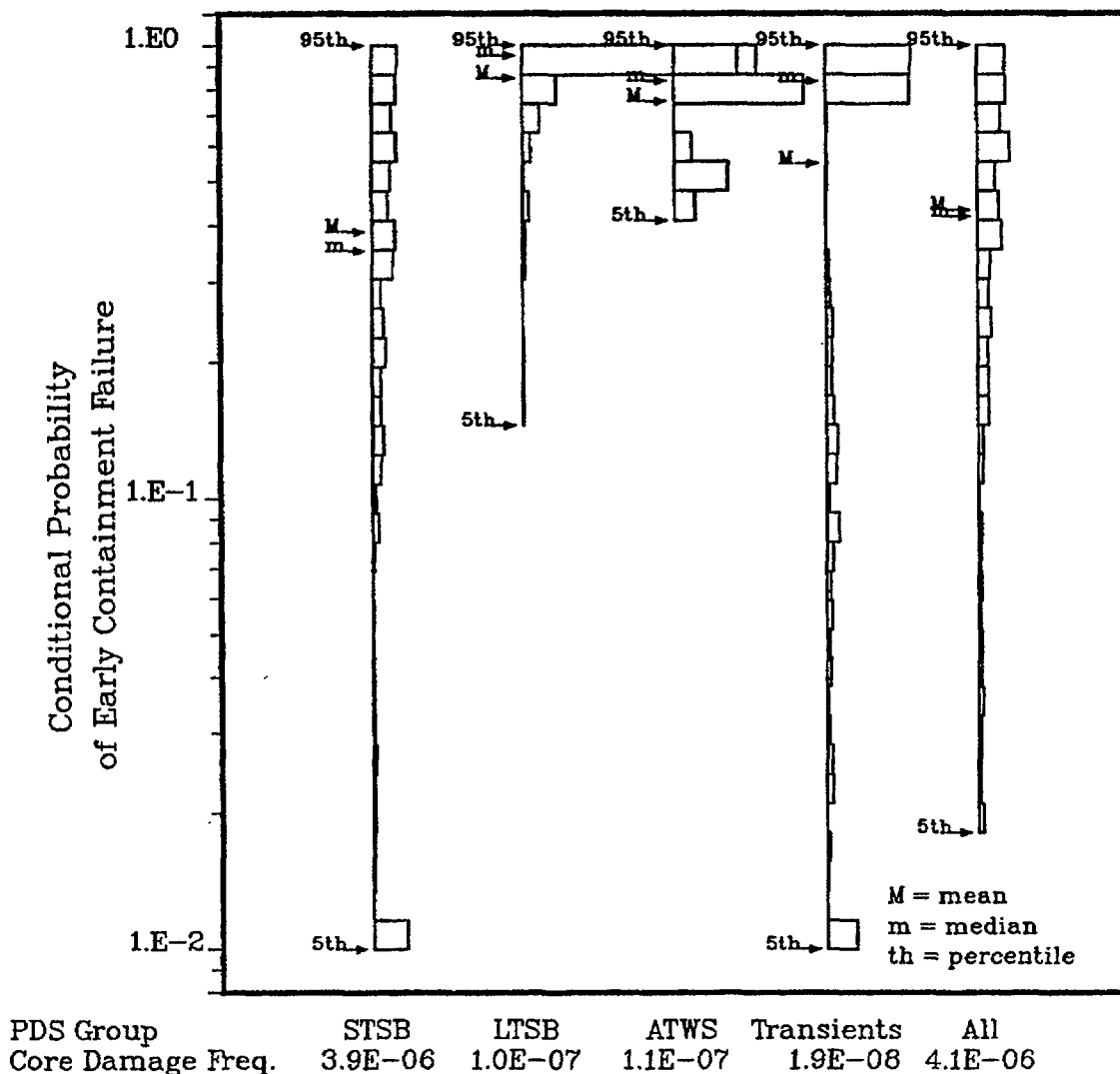

Figure 6.5 Conditional probability distributions for early containment failure at Grand Gulf.

3. Hydrogen Ignition System

The Grand Gulf containment hydrogen ignition system is capable of maintaining the concentration of hydrogen from severe accidents in manageable proportions for many severe accidents. However, for station blackout accident sequences, the igniter system is not operable. When power is restored, the ignition system will be initiated; potentially the containment has high hydrogen concentrations. Some potential then exists for a deflagration causing simultaneous failures of both the containment building and the drywell structure.

4. Containment Spray System

The Grand Gulf containment spray system has the capability to condense steam and reduce the amount of radioactive material released to the environment for specific accident sequences. However, for some sequences, i.e., loss of ac power, its eventual initiation upon power recovery and that of the hydrogen ignition system could result in subsequent hydrogen combustion that has some potential to fail the containment and drywell.

6.4 Source Term Analysis

6.4.1 Results of Source Term Analysis

A key difference between the Peach Bottom (Mark I) design and Grand Gulf (Mark III) design is the wetwell/drywell configuration. If the drywell remains intact in the accident and the mode of containment failure does not result in loss of the suppression pool, leakage to the environment must pass through the pool and be subject to decontamination.

Figures 6.6 and 6.7 illustrate the effect of drywell integrity in mitigating the environmental release of radionuclides for early containment failure. In Figure 6.6, both the drywell and the containment fail early and sprays are not available. The median release for the volatile radionuclides is approximately 10 percent, indicative of a large release with the potential for causing early fatalities. For the early containment failure accident progression bin with the drywell intact, as illustrated in Figure 6.7, the environmental source terms are reduced, since the flow of gases escaping the containment after vessel breach must also pass through the suppression pool before being released to the environment.

Additional discussion on source term perspectives (for all studied plants) is provided in Chapter 10.

6.4.2 Important Plant Characteristics (Source Term)

1. Suppression Pool

The pressure-suppression pool at Grand Gulf provides the potential for substantial mitigation of the source terms in severe accidents. Since transient-initiated accidents represent a large contribution to core damage frequency, the in-vessel release of radionuclides is almost always subject to pool decontamination. Only a fraction of such accident sequences (in which a vacuum breaker sticks open in a safety relief valve discharge line) releases radionuclides directly to the drywell in this phase of the accident. The pool decontamination factors used for the Grand Gulf design for the in-vessel release range from 1.1 to 4000, with a median of 60. For the ex-vessel release component, the pool is less effective. The decontamination factors range from 1 to 90 with a median of 7.

2. Wetwell-Drywell Configuration

If the drywell remains intact in a severe accident at Grand Gulf, the radionuclide release

would be forced to pass through the suppression pool and the source term would be substantially mitigated. However, the likelihood of drywell failure is estimated to be quite significant, such that early failure with suppression pool bypass occurs approximately one-quarter of the time if core melting and vessel breach occur.

3. Pedestal Flooding

The pedestal region communicates with the drywell region through drains in the drywell floor. The amount of water in the pedestal region depends on whether the upper water pool has been dumped into the suppression pool, on the quantity of condensate storage that has been injected into the containment, and on the transient pressurization of the containment building resulting from hydrogen burns. The effect of water in the pedestal is either to result in debris coolability or to mitigate the source term to containment of the radionuclides released during core-concrete interaction. Water in the pedestal does, however, also introduce some potential for a steam explosion that can damage the drywell.

4. Containment Sprays

Containment sprays can have a mitigating effect on the release of radionuclides under conditions in which both the containment and drywell have failed. In other accident scenarios in which the in-vessel and ex-vessel releases must pass through the suppression pool before reaching the outer containment region, sprays are not nearly as important. This is, in part, because the source term has already been reduced and, in part, because the decontamination factors for suppression pools and containment sprays are not multiplicative since they selectively remove similar-sized aerosols.

6.5 Offsite Consequence Results

Figure 6.8 displays the frequency distributions in the form of graphical plots of the complementary cumulative distribution functions (CCDFs) of four offsite consequence measures—early fatalities, latent cancer fatalities, and the 50-mile and the entire site region population exposures (in person-rems). These CCDFs include contributions from all source terms associated with reactor accidents caused by internal initiating events. Four CCDFs,

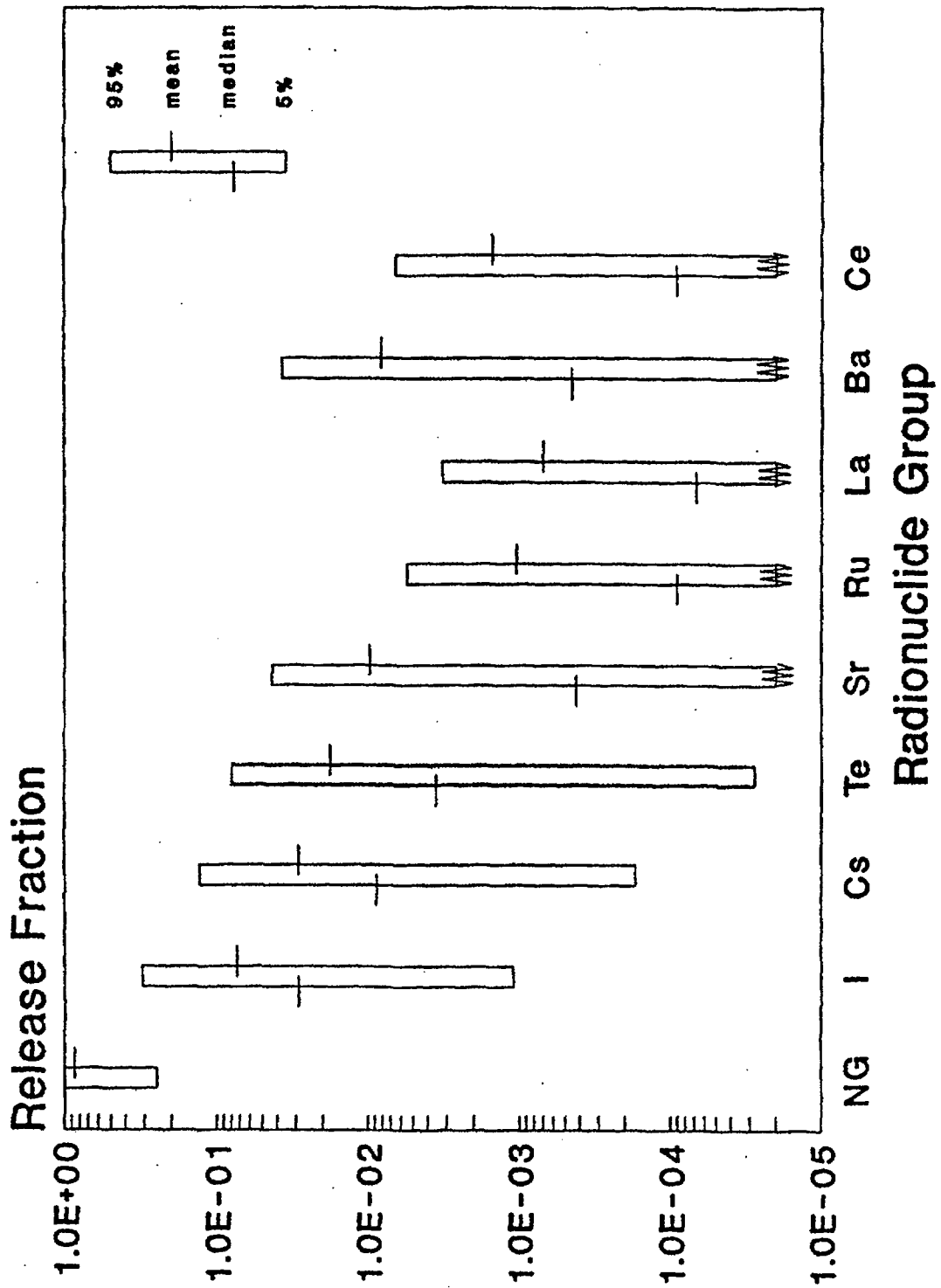

Figure 6.6 Source term distributions for early containment failure with drywell failed and sprays unavailable at Grand Gulf.

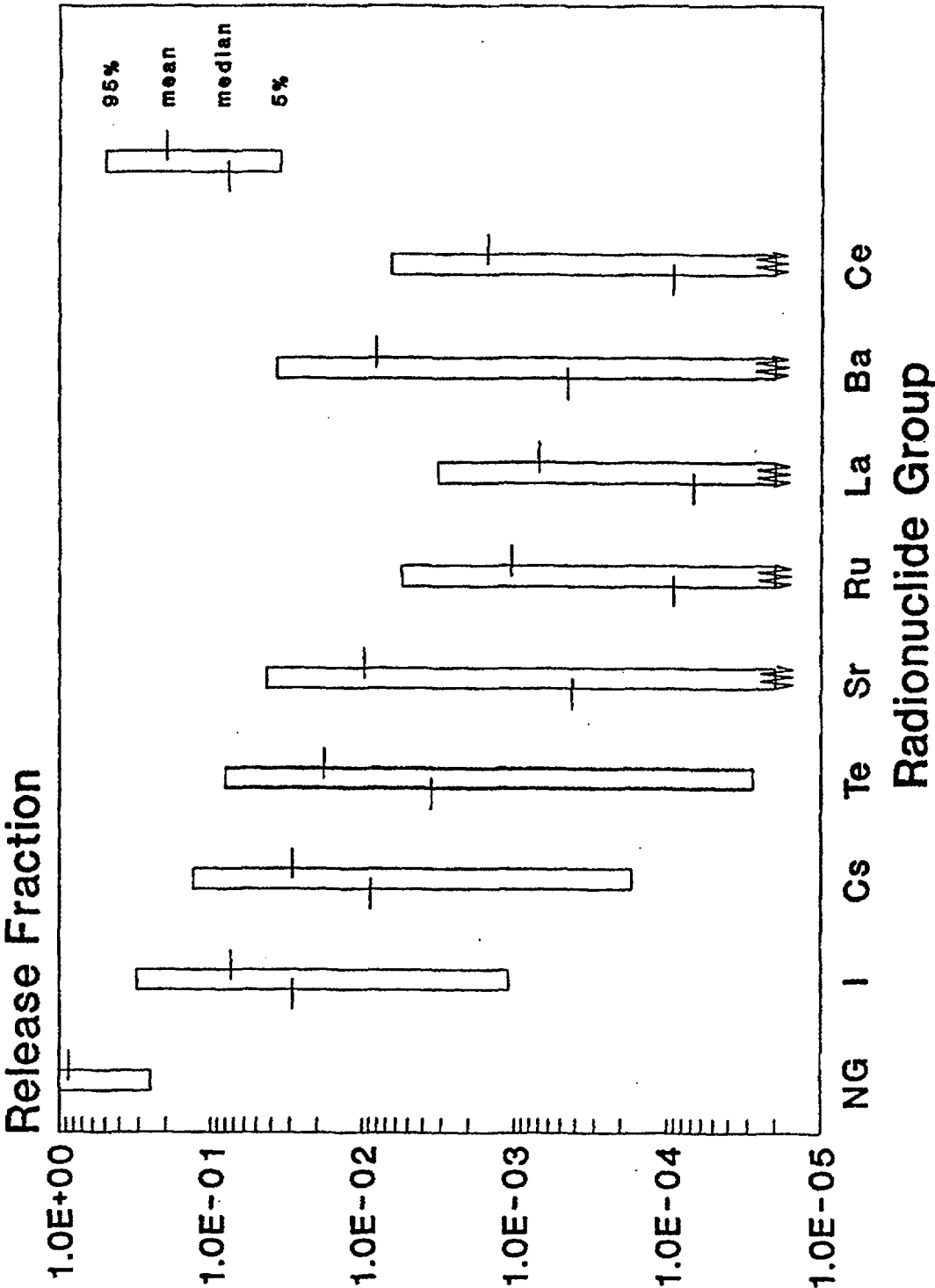
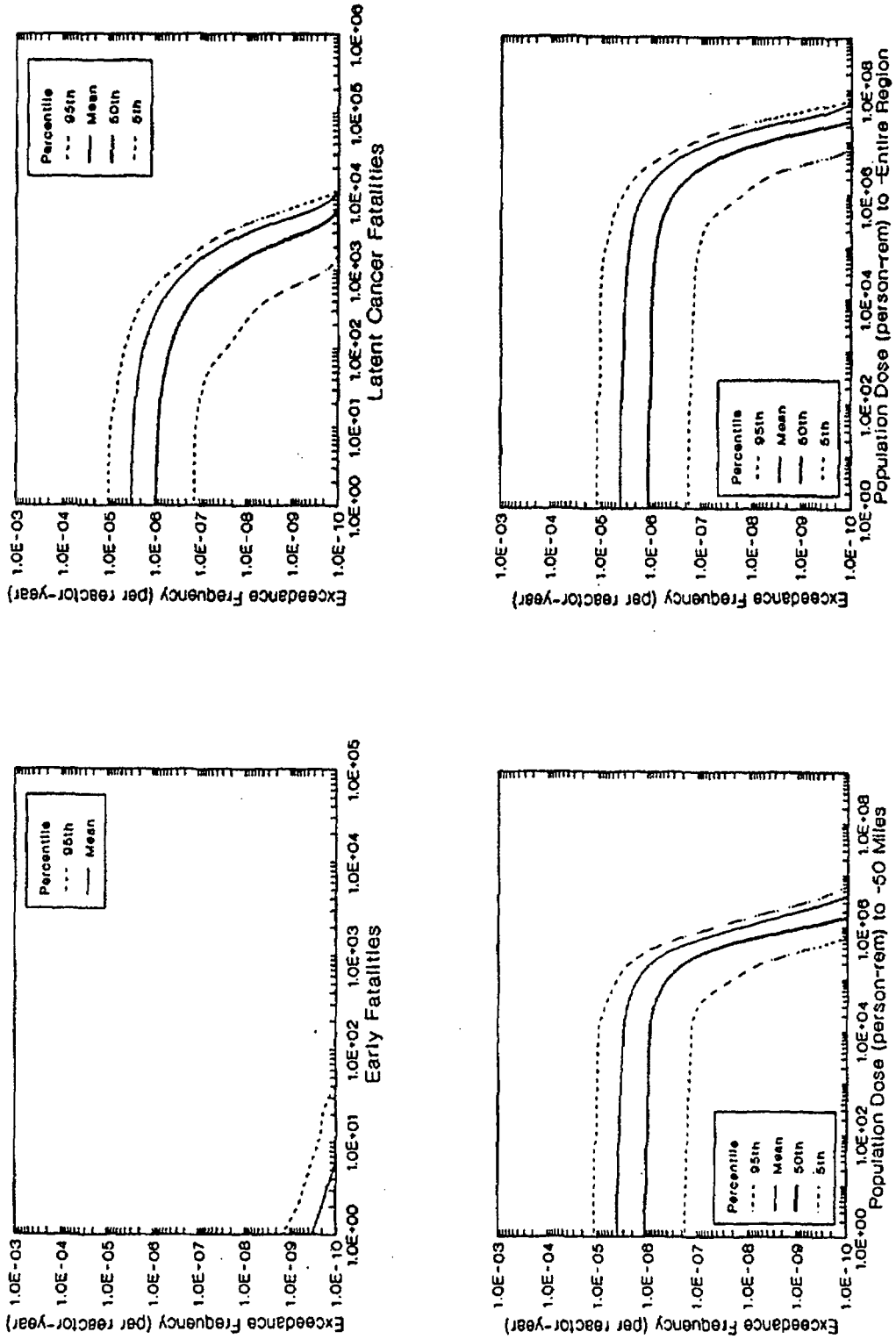

Figure 6.7 Source term distributions for early containment failure with drywell intact at Grand Gulf.

6. Grand Gulf Plant Results



Note: As discussed in Reference 6.4, estimated consequences at frequencies at or below $1E-7$ per reactor year should be viewed with caution because of the potential impact of events not studied in the risk analyses.

Figure 6.8 Frequency distributions of offsite consequence measures at Grand Gulf (internal initiators).

namely, the 5th percentile, 50th percentile (median), 95th percentile, and the mean CCDFs, are shown for each consequence measure.

Grand Gulf plant-specific and site-specific parameters were used in the consequence analysis for these CCDFs. The plant-specific parameters included source terms and their frequencies, the licensed thermal power (3833 MWt) of the reactor, and the approximate physical dimensions of the power plant building complex. The site-specific parameters included exclusion area radius (696 meters), meteorological data for 1 full year collected at the meteorological tower, the site region population distribution based on the 1980 census data, topography (fraction of the area that is land—the remaining fraction is assumed to be water), land use, agricultural practice and productivity, and other economic data for up to 1,000 miles from the Grand Gulf plant.

The consequence estimates displayed in these figures have incorporated the benefits of the following protective measures: (1) evacuation of 99.5 percent of the population within the 10-mile plume exposure pathway emergency planning zone (EPZ), (2) early relocation of the remaining population only from the heavily contaminated areas both within and outside the 10-mile EPZ, and (3) decontamination, temporary interdiction, or condemnation of land, property, and foods contaminated above acceptable levels.

The population density within the Grand Gulf 10-mile EPZ is about 30 persons per square mile. The average delay time before evacuation (after a warning prior to radionuclide release) from the 10-mile EPZ and average effective evacuation speed used in the analyses were derived from information contained in a utility-sponsored Grand Gulf evacuation time estimate study (Ref. 6.6) and the NRC requirements for emergency planning.

The results displayed in Figure 6.8 are discussed in Chapter 11.

6.6 Public Risk Estimates

6.6.1 Results of Public Risk Estimates

A detailed description of the results of the Grand Gulf risk analysis is provided in Reference 6.2. For this summary report, results are provided for the following measures of public risk:

- Early fatality risk,

- Latent cancer fatality risk,
- Population dose within 50 miles of the site,
- Population dose within the entire site region,
- Individual early fatality risk in the population within 1 mile of the Grand Gulf exclusion area boundary, and
- Individual latent cancer fatality risk in the population within 10 miles of the Grand Gulf site.

The first four of the above measures are commonly used measures in nuclear power plant risk studies. The last two are those used to compare with the NRC safety goals (Ref. 6.7).

The results of the Grand Gulf risk studies using the above measures are shown in Figures 6.9 through 6.11. The figures display the variabilities in mean risks estimated from meteorology-averaged conditional mean values of the consequence measures. In comparison to the risks from the other plants in this study, Grand Gulf has the lowest risk estimates. The results are much below those of the Reactor Safety Study (Ref. 6.8). The individual early and latent cancer fatality risks are far below the NRC safety goals. Details of the comparison of results are provided in Chapter 12.

The results in Figure 6.9 have been analyzed to identify the relative contributions of accident sequences and containment failure modes to mean risk. These results are presented in Figures 6.12 and 6.13. As may be seen, the mean early fatality risk at Grand Gulf is dominated by short-term station blackout sequences. The majority of early fatality risk is associated with the coincidence of early containment failure and early suppression pool bypass.

The mean latent cancer fatality risk is also dominated by the short-term station blackout group. The major contributors to risk are from (1) early containment and early suppression pool bypass, and (2) late containment failure.

6.6.2 Important Plant Characteristics (Risk)

As mentioned before, risk to the public from the operation of the Grand Gulf plant is lower than the other four plants in this study. Some of the plant features that contribute to these low risk estimates are described below.

- The very low early fatality risk at Grand Gulf is due to a combination of low core damage

6. Grand Gulf Plant Results

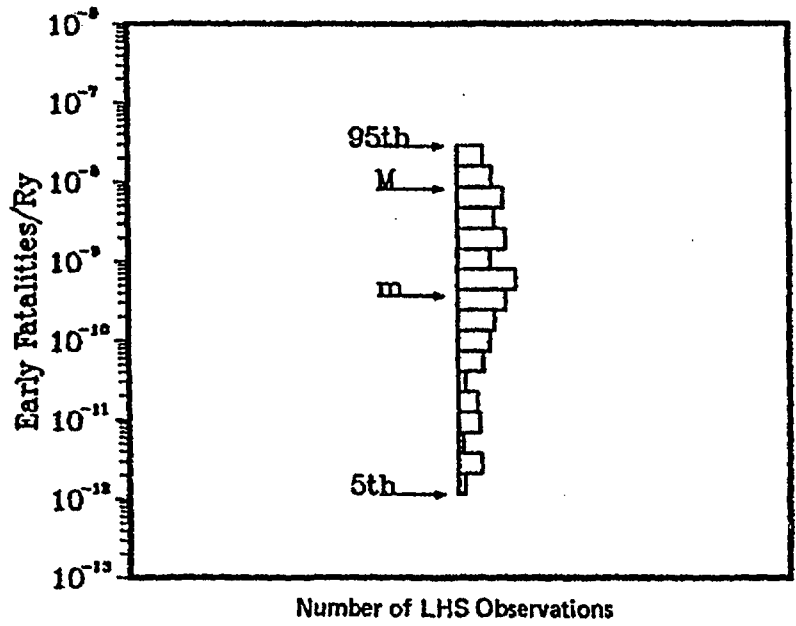

Key: M = mean
 m = median
 th = percentile

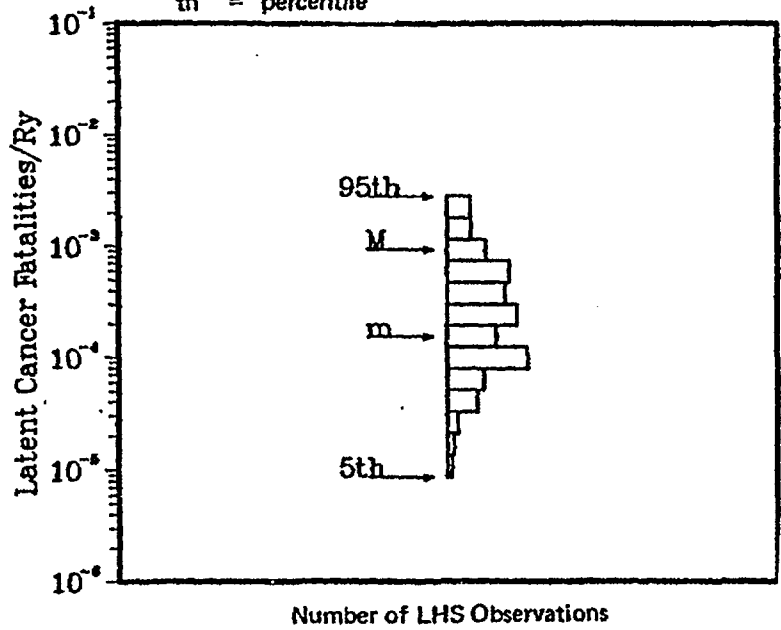

Note: As discussed in Reference 6.4, estimated risks at or below $1E-7$ per reactor year should be viewed with caution because of the potential impact of events not studied in the risk analyses.

Figure 6.9 Early and latent cancer fatality risks at Grand Gulf (internal initiators).

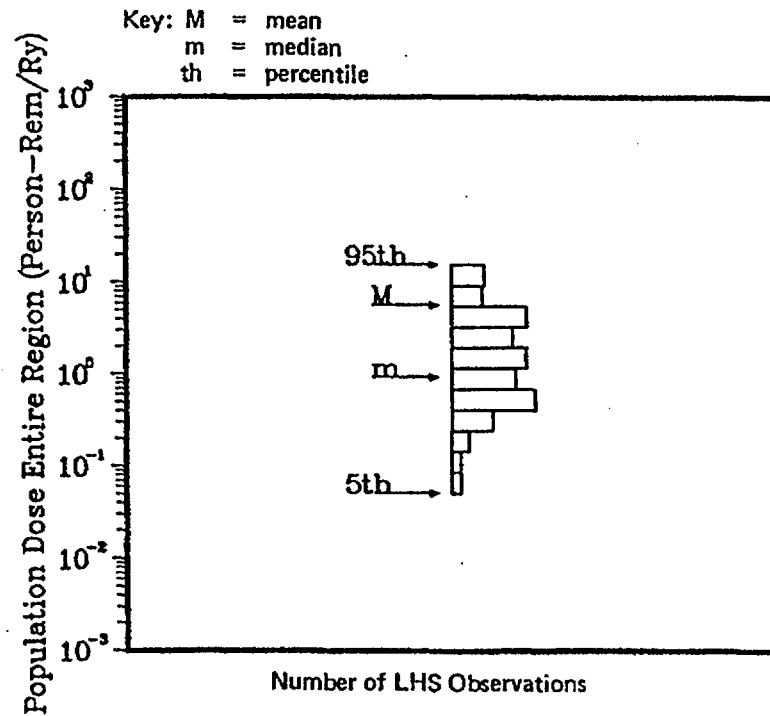
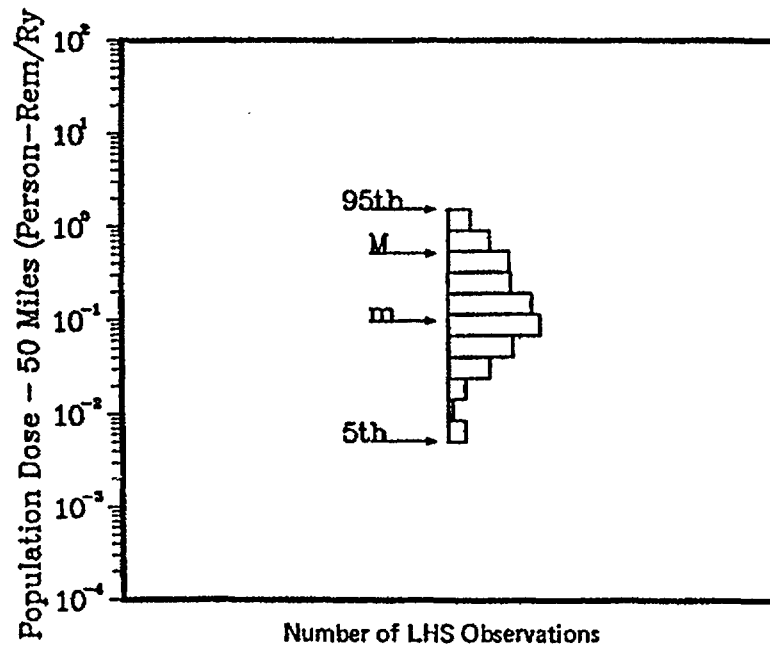

Note: As discussed in Reference 6.4, estimated risks at or below $1E-7$ per reactor year should be viewed with caution because of the potential impact of events not studied in the risk analyses.

Figure 6.10 Population dose risks at Grand Gulf (internal initiators).

6. Grand Gulf Plant Results

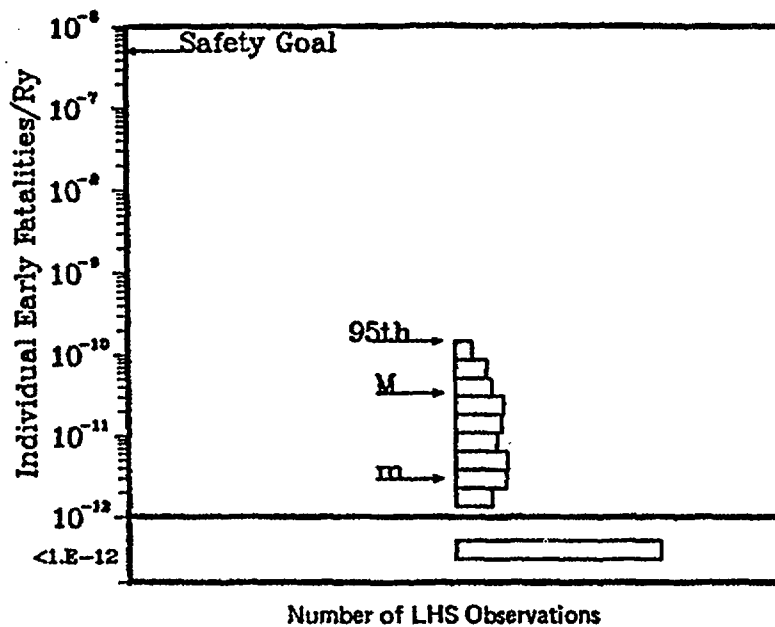

Key: M = mean
 m = median
 th = percentile

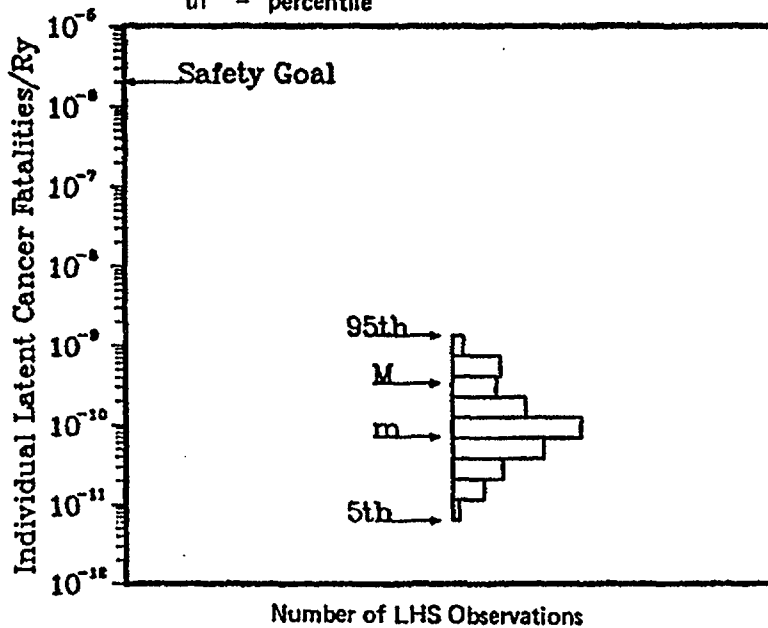

Note: As discussed in Reference 6.4, estimated risks at or below $1E-7$ per reactor year should be viewed with caution because of the potential impact of events not studied in the risk analyses.

Figure 6.11 Individual early and latent cancer fatality risks at Grand Gulf (internal initiators).

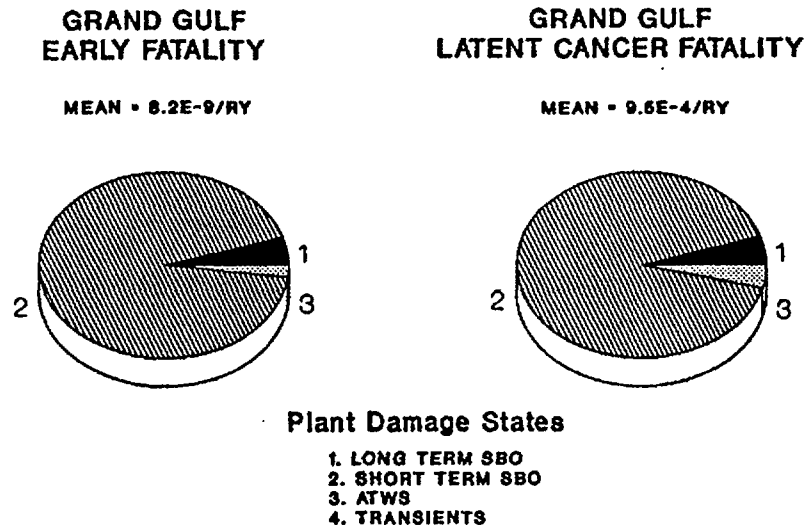

Figure 6.12 Major contributors (plant damage states) to mean early and latent cancer fatality risks at Grand Gulf (internal initiators).

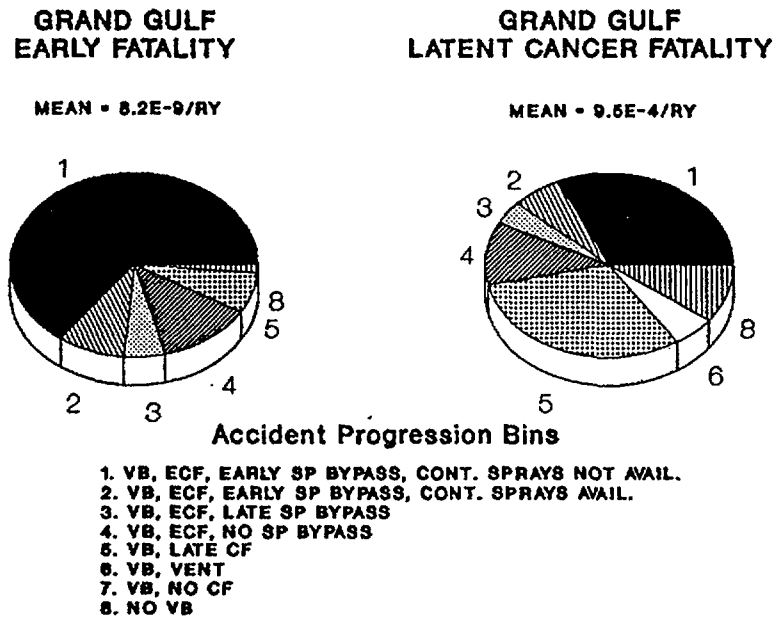

Figure 6.13 Major contributors (accident progression bins) to mean early and latent cancer fatality risks at Grand Gulf (internal initiators).

6. Grand Gulf Plant Results

frequency, reduced source terms (as a result of suppression pool scrubbing), and low population density around the plant. The latter leads to short evacuation delays and fast evacuation speeds. Timing is not as important for latent cancer fatalities.

- Although the Grand Gulf plant has relatively high probability of early containment failure, caused mainly by hydrogen deflagration, the probability of early drywell failure, which may lead to a large source term, is about half of

the probability of early containment failure. Furthermore, in most cases, in-vessel releases pass through the suppression pool.

- There is a high probability of having water in the reactor cavity following vessel breach. Thus, there is a high probability that core debris would be coolable. Even when any core-concrete interaction may occur, it is generally under water, and, therefore, the resulting releases are scrubbed by overlaying water (if not by the suppression pool).

REFERENCES FOR CHAPTER 6

- 6.1 M. T. Drouin et al., "Analysis of Core Damage Frequency: Grand Gulf Unit 1," Sandia National Laboratories, NUREG/CR-4550, Vol. 6, Revision 1, SAND86-2084, September 1989.
- 6.2 T. D. Brown et al., "Evaluation of Severe Accident Risks: Grand Gulf Unit 1," Sandia National Laboratories, NUREG/CR-4551, Vol. 6, Draft Revision 1, SAND86-1309, to be published.*
- 6.3 S. W. Hatch et al., "Reactor Safety Study Methodology Applications Program: Grand Gulf No. 1 BWR Power Plant," Sandia National Laboratories and Battelle Columbus Laboratories, NUREG/CR-1659/4 of 4, SAND80-1897/4 of 4, November 1981.
- 6.4 H. J. C. Kouts et al., "Special Committee Review of the Nuclear Regulatory Commission's Severe Accident Risks Report (NUREG-1150)," NUREG-1420, August 1990.
- 6.5 A. D. Swain III, "Accident Sequence Evaluation Program—Human Reliability Analysis Procedure," Sandia National Laboratories, NUREG/CR-4772, SAND86-1996, February 1987.
- 6.6 Mississippi Power & Light Company, "Evacuation Time Estimates for the Grand Gulf Nuclear Station Plume Exposure Pathway Emergency Planning Zone," Revision 4, March 1986.
- 6.7 USNRC, "Safety Goals for the Operation of Nuclear Power Plants; Policy Statement," *Federal Register*, Vol. 51, p. 30028, August 21, 1986.
- 6.8 USNRC, "Reactor Safety Study—An Assessment of Accident Risks in U.S Commercial Nuclear Power Plants," WASH-1400 (NUREG-75/014), October 1975.

*Available in the NRC Public Document Room, 2120 L Street NW., Washington, DC.

7. ZION PLANT RESULTS

7.1 Summary Design Information

The Zion Nuclear Plant is a two-unit site. Each unit is a four-loop Westinghouse nuclear steam supply system rated at 1100 MWe and is housed in a large, prestressed concrete, steel-lined dry containment. The balance of plant systems were engineered by Sargent & Lundy. Located on the shore of Lake Michigan, about 40 miles north of Chicago, Illinois, Zion 1 started commercial operation in December 1973. Some important design features of the Zion plant are described in Table 7.1. A general plant schematic is provided in Figure 7.1.

This chapter provides a summary of the results provided in the risk analyses underlying this report (Refs. 7.1 and 7.2). A discussion of perspectives with respect to these results is provided in Chapters 8 through 12.

7.2 Core Damage Frequency Estimates

7.2.1 Summary of Core Damage Frequency Estimates*

The core damage frequency and risk analyses performed for this study considered accidents initiated only by internal events (Ref. 7.1); no external-event analyses were performed. The core damage frequency results obtained are provided in tabular form in Table 7.2. This study calculated a total median core damage frequency from internal events of $2.4E-4$ per year.

7.2.1.1 Zion Analysis Approach

The Zion plant was previously analyzed in the Zion Probabilistic Safety Study (ZPSS), performed by the Commonwealth Edison Company, and in the review and evaluation of the ZPSS (Ref. 7.3), commonly called the Zion Review prepared by Sandia National Laboratories.

Since previous analyses of Zion already existed, it was decided to perform an update of the previous analyses rather than perform a complete reanalysis. Therefore, this analysis of Zion represents a limited rebaseline and extension of the dominant accident sequences from the ZPSS in light of the Zion Review comments, although in-

*In general, the results and perspectives provided here do not reflect recent modifications to the Zion plant. The benefit of the changes is noted, however, in specific places in the text (and discussed in more detail in Section 15 of Appendix C).

corporating some methods and issues (such as common-cause failure treatment, electric power recovery, and reactor coolant pump seal LOCA modeling) used in the other four plant studies.

The objective of this study was to perform an analysis that updated the previous Zion analyses and cast the model in a manner more consistent with the other accident frequency analyses. The models were not completely reconstructed in the small-event-tree, large-fault-tree modeling method used in the study of the other NUREG-1150 plants. Instead, the small-fault-tree, large-event-tree models from the original ZPSS were used as the basis for the update. These models were then revised according to the comments from Reference 7.3 and were enhanced to address risk issues using methods employed by the other plant studies.

This study incorporated specific issues into the systems and accident sequence models of the ZPSS. These issues reflect both changes in the Zion plant and general PRA assumptions that have arisen since the ZPSS was performed. New dominant accident sequences were determined by modifying and requantifying the event tree models developed for ZPSS. The major changes reflect the need for component cooling water and service water for emergency core cooling equipment and reactor coolant pump seal integrity. The original set of plant-specific data used in the ZPSS and Zion Review was verified as still valid and was used for this study. Additional discussion of the Zion methods is provided in Appendix A.

7.2.1.2 Internally Initiated Accident Sequences

A detailed description of accident sequences important at the Zion plant is provided in Reference 7.1. For this summary report, the accident sequences described in that reference have been grouped into six summary plant damage states. These are:

- Station blackout,
- Loss-of-coolant accident (LOCA),
- Component cooling water and service water induced reactor coolant pump seal LOCAs,
- Anticipated transients without scram (ATWS),

Table 7.1 Summary of design features: Zion Unit 1.

| | |
|----------------------------|--|
| 1. High-Pressure Injection | <ul style="list-style-type: none"> a. Two centrifugal charging pumps. b. Two 1500-psig safety injection pumps. c. Charging pumps inject through boron injection tank. d. Provides seal injection flow. e. Requires component cooling water. |
| 2. Low-Pressure Injection | <ul style="list-style-type: none"> a. Two RHR pumps deliver flow when RCS is below about 170 psig. b. Heat exchangers downstream of pumps provide recirculation heat removal. c. Recirculation mode takes suction on containment sump and discharges to the RCS, HPI suction, and/or containment spray pump suction. d. Pumps and heat exchangers require component cooling water. |
| 3. Auxiliary Feedwater | <ul style="list-style-type: none"> a. Two 50 percent motor-driven pumps and one 100 percent turbine-driven pump. b. Pumps take suction from own unit condensate storage tank (CST) but can be manually cross-tied to the other unit's CST. |
| 4. Emergency Power System | <ul style="list-style-type: none"> a. Each unit consists of three 4160 VAC class 1E buses, each feeding one 480 VAC class 1E bus and motor control center. b. For the two units there are 5 diesel generators, with one being a swing diesel generator shared by both units. c. Three trains of dc power are supplied from the inverters and 3 unit batteries. |
| 5. Component Cooling Water | <ul style="list-style-type: none"> a. Shared system between both units. b. Consists of 5 pumps, 3 heat exchangers, and 2 surge tanks. c. Cools RHR heat exchangers, RCP motors and thermal barriers, RHR pumps, SI pumps, and charging pumps. d. One of 5 pumps can provide sufficient flow. |
| 6. Service Water | <ul style="list-style-type: none"> a. Shared system between both units. b. Consists of 6 pumps and 2 supply headers. c. Cools component cooling heat exchangers, containment fan coolers, diesel generator coolers, auxiliary feedwater pumps. d. Two of 6 pumps can supply sufficient flow. |
| 7. Containment Structure | <ul style="list-style-type: none"> a. Large, dry, prestressed concrete. b. 2.6 million cubic foot volume. c. 49 psig design pressure. |
| 8. Containment Spray | <ul style="list-style-type: none"> a. Two motor-driven pumps and 1 independent diesel-driven pump. b. No train cross-ties. c. Water supplied by refueling water storage tank. |
| 9. Containment Fan Coolers | <ul style="list-style-type: none"> a. Five fan cooler units, a minimum of 3 needed for post-accident heat removal. b. Fan units shift to low speed on SI signal. c. Coolers require service water. |

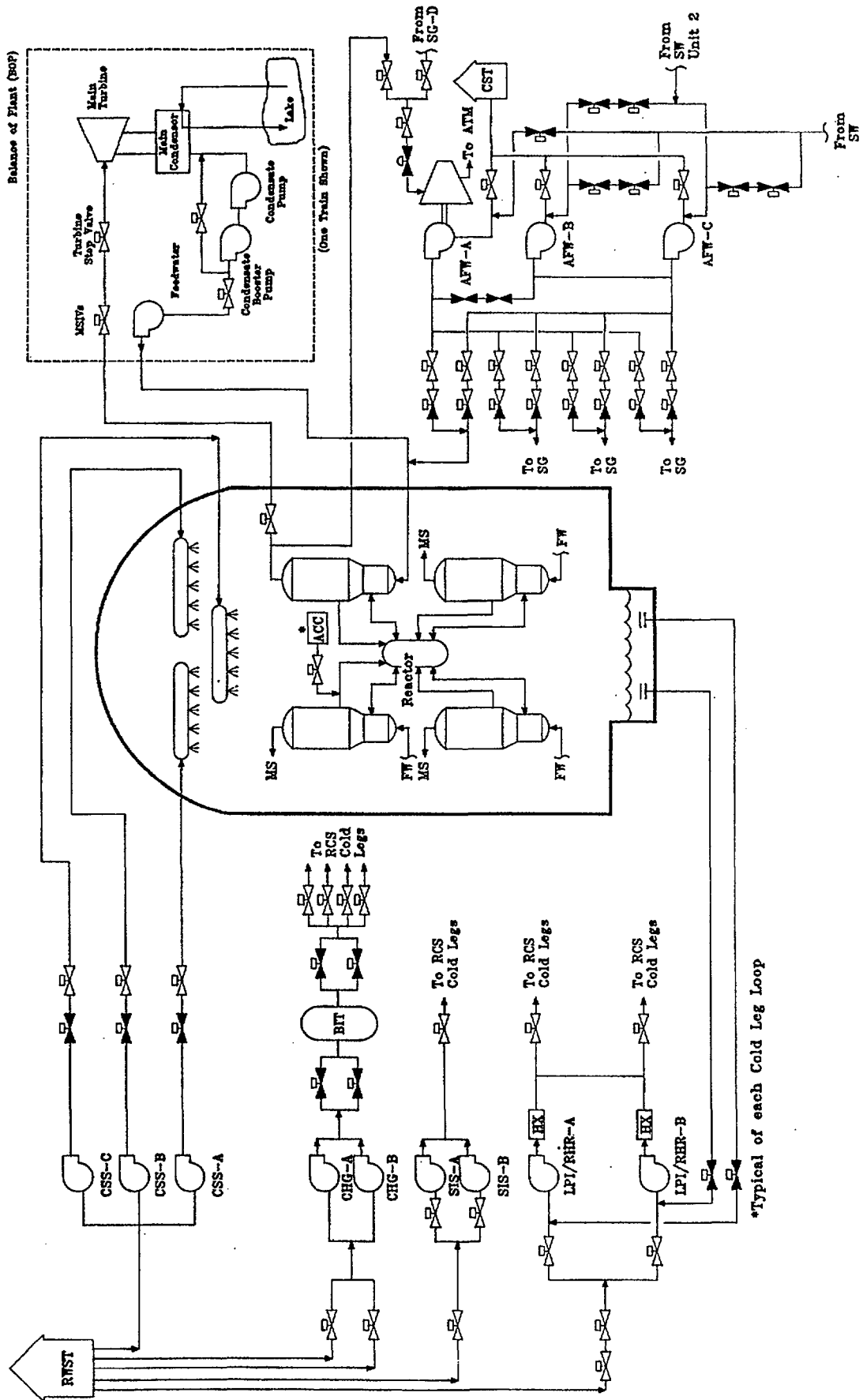

Figure 7.1 Zion plant schematic.

7. Zion Plant Results

Table 7.2 Summary of core damage frequency results: Zion.

| | 5% | Median | Mean | 95% |
|-----------------|--------|--------|---------|--------|
| Internal Events | 1.1E-4 | 2.4E-4 | 3.4E-4* | 8.4E-4 |

*See text (Section 7.2.1) for benefit of recent modifications.

- Interfacing-system LOCA and steam generator tube rupture (SGTR), and
- Transients other than station blackout and ATWS.

The relative contribution of the accident types to mean core damage frequency at Zion is shown in Figure 7.2. It is seen that the dominating contributors to the core damage frequency are the loss of component cooling water and loss of service water. The more probable combinations of failures are:

- Reactor coolant pump seals fail because of the loss of cooling and injection. Core damage occurs because of failure to recover the service water/component cooling water systems in time to reestablish reactor coolant system inventory control. In cases with failure of the service water system, containment fan coolers are also failed.
- Reactor coolant pump seals fail because of the loss of cooling and injection. The cooling system is recovered in time to provide injection from the refueling water storage tank (RWST). Recirculation cooling fails to continue to provide long-term inventory control.

To address the issue of the importance of component cooling water system failures, Commonwealth Edison (the Zion licensee) committed in 1989 to perform the following actions (Ref. 7.4):

- Provide an auxiliary water supply to each charging pump's oil cooler via either the service water system or fire protection system. Hoses, fittings, and tools will be maintained locally at each unit's charging pump area allowing for immediate hookup to existing taps on the oil coolers, if required. As an interim measure, a standing order in the control room will instruct operators as to how and when to hook up auxiliary water to the oil coolers.
- Formal procedures, including a 10 CFR 50.59 review addressing the loss of compo-

nent cooling water system scenario, will be fully implemented within 60 days (of the date of Ref. 7.4) to supersede the standing order.

- When new heat-resistant reactor coolant pump seal o-rings are made available by Westinghouse, the existing o-rings will be changed when each pump is disassembled for routine scheduled seal maintenance.

These actions provide a backup water source to the Zion station charging pump oil coolers.

As of October 1990, Commonwealth Edison had performed some of the noted actions (Ref. 7.5). Sensitivity studies have been performed to assess the benefit of the modifications made to date. These studies, discussed in more detail in Section C.15 of Appendix C, indicate that the Zion estimated mean core damage frequency has been reduced from 3.4E-4 per year to approximately 6E-5 per year.

7.2.2 Important Plant Characteristics (Core Damage Frequency)

Characteristics of the Zion plant design and operation that have been found to be important in the analysis of the core damage frequency include:

1. Shared Systems Between Units

The Zion nuclear station shares the service water and component cooling water (CCW) systems between the two units. Power is supplied to these systems from all five onsite diesel generators.

2. Crossties Between Units

Crossties between units exist for the condensate storage tanks to provide water supply for the auxiliary feedwater system. Crossties also exist between Unit 1 and Unit 2 ac power systems, as well as between Unit 1 and Unit 2 dc power systems.

CCW-Induced Seal LOCA

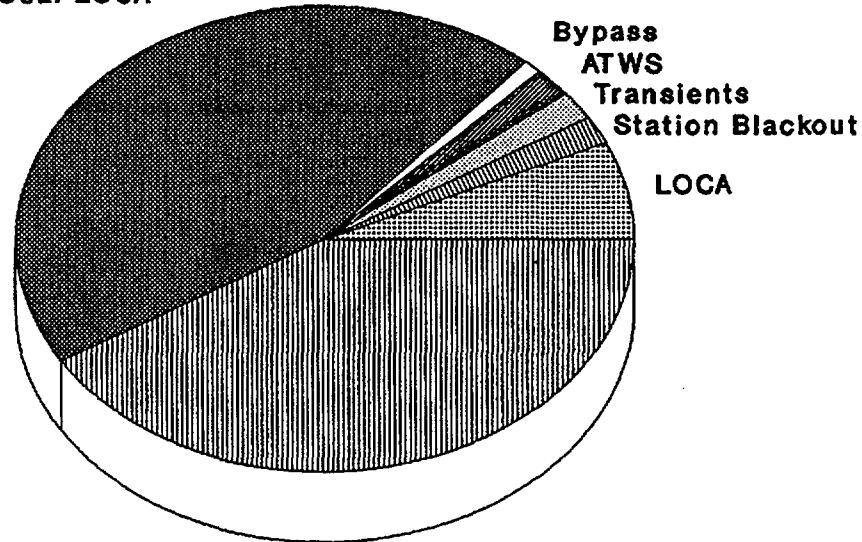

Total Mean Core Damage Frequency: 3.4E-4

Note: See text (Section 7.2.1) for benefit of recent modifications.

Figure 7.2 Contributors to mean core damage frequency from internal events at Zion.

3. Diesel Generators

Zion is a two-unit site with five emergency diesel generators. One diesel generator is a swing diesel that can be lined up to supply either unit. This differs from a number of other two-unit sites that have only four diesel generators on site. The Zion diesel generators are dependent on a common service water system for sustained operation.

4. Support System Dependencies

The component cooling water system supplies cooling water for the reactor coolant pump thermal barriers and for the charging pumps that supply seal injection. Failure of the component cooling water system results in a major challenge to reactor coolant pump seal integrity. In addition, failure of the component cooling water support systems (service water

and ac power) also leads to loss of reactor coolant pump seal integrity. In contrast, some other PWRs do not have a common dependency for both seal cooling and seal injection; therefore, at other PWRs, seal LOCAs are only important in station blackout cases. As indicated above, the licensee has committed to and implemented plant changes to reduce this dependency.

5. Battery Depletion Time

The battery depletion time following a complete loss of all ac power was estimated at 6 hours, somewhat longer than that found at some other plants. The additional time tends to reduce the significance of the station blackout sequences as contributors to the core damage frequency.

7. Zion Plant Results

6. Reactor Coolant Pump Seal Performance

The inability of the reactor coolant pump seals to survive loss of cooling and injection without developing significant leakage dominates the core damage frequency. As noted above, the licensee has committed to replacing present seals with a new model.

7.2.3 Important Operator Actions

Several operator actions and recovery actions are important to the analysis of the core damage frequency. While the analysis included a wide range of operator actions from test and maintenance errors before an initiating event to recovery actions well into an accident sequence, the following actions surface as the most important:

- Successful switchover to recirculation

The operator must recognize that switchover should be initiated, take action to open the proper set of motor-operated valves depending on reactor coolant system conditions, and verify that recirculation flow is proper.

- Successful execution of feed and bleed cooling

The operator must recognize that secondary cooling is lost, establish sufficient injection flow, open both power-operated relief valves (and their block valves, if necessary), and verify that adequate heat removal is taking place.

- Recovery of the component cooling water and service water systems

The operator must recognize that the failure of equipment or rising equipment operating temperatures are due to failure of the service water or component cooling water systems, determine the cause of system failure, and take appropriate action to isolate ruptures, restart pumps, and provide alternative cooling paths as required by the situation.

- Actions to refill the RWST in the event of recirculation failure

This action requires that the operator recognize the failure of recirculation cooling in sufficient time that refill can begin before core damage occurs. The operator must then carry out the procedure for emergency refill

of the RWST. This action is not adequate for inventory control in the case of larger LOCAs because of the limitations of the refilling equipment.

Switchover to recirculation cooling and initiation of feed and bleed cooling were included in the original Zion Probabilistic Safety Study and have been given close scrutiny by the licensee. Each one of these actions is present in the emergency procedures. Appropriate consideration of the procedures, scenarios, timing, and training went into the determination of the human error probabilities associated with these actions. Because of the importance and uncertainty associated with several of these actions, they were addressed in the sensitivity analyses. However, the refilling of the RWST in the event of recirculation failure and recovery of CCW and service water were not included in the original Zion Probabilistic Safety Study. Appropriate consideration of the procedures, scenarios, timing, and training went into the determination of the human error probabilities associated with these actions. Because of the importance and uncertainty associated with several of these actions, they were addressed in the sensitivity analyses.

7.3 Containment Performance Analysis

7.3.1 Results of Containment Performance Analysis

The Zion containment consists of a large, dry containment building that houses the reactor pressure vessel, reactor coolant system piping, and the secondary system's steam generators. The containment building is a prestressed concrete structure with a steel liner. This building has a volume of 2.6 million cubic feet with a design pressure of 49 psig and an estimated mean failure pressure of 150 psia. The principal threats to containment integrity from potential severe accident sequences are steam explosions, overpressurization from direct containment heating effects, bypass events, and isolation failures. As previously discussed in Chapter 2, the methods used to estimate loads and containment structural response for Zion made extensive use of expert judgment to interpret and supplement the limited data (Ref. 7.2).

The results of the Zion containment analysis are summarized in Figures 7.3 and 7.4. Figure 7.3 displays information in which the conditional probabilities of four accident progression bins, e.g., early containment failure, are presented for each of five plant damage states, e.g., LOCA. This information indicates that, on a plant damage

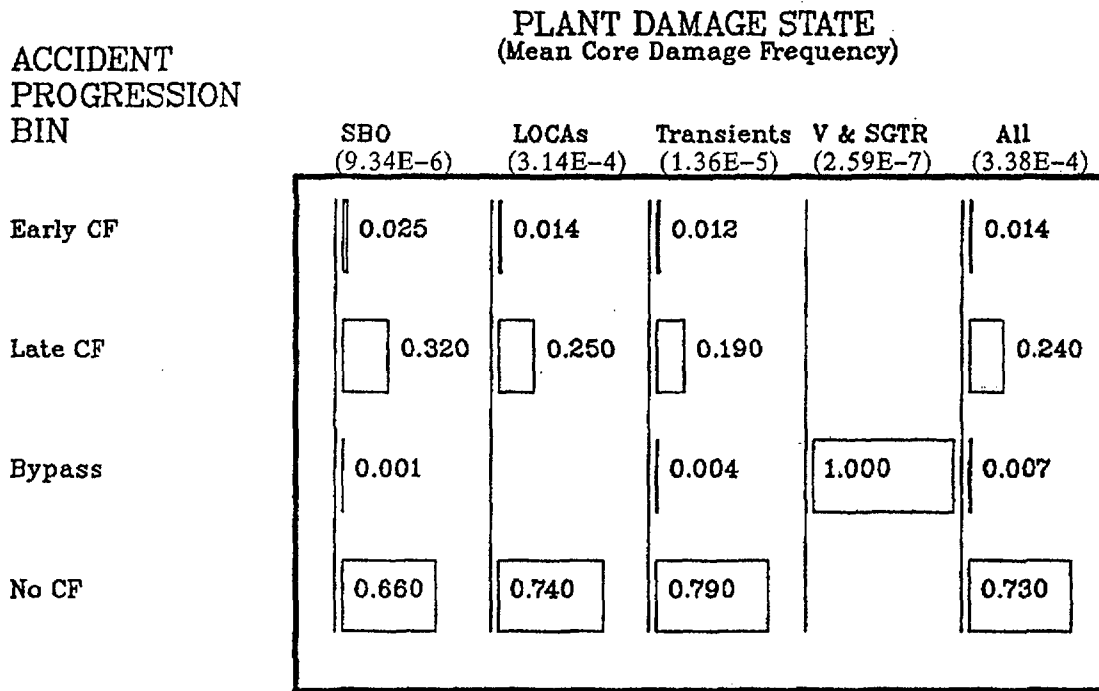

Key: CF = Containment Failure

Figure 7.3 Conditional probability of accident progression bins at Zion.

7. Zion Plant Results

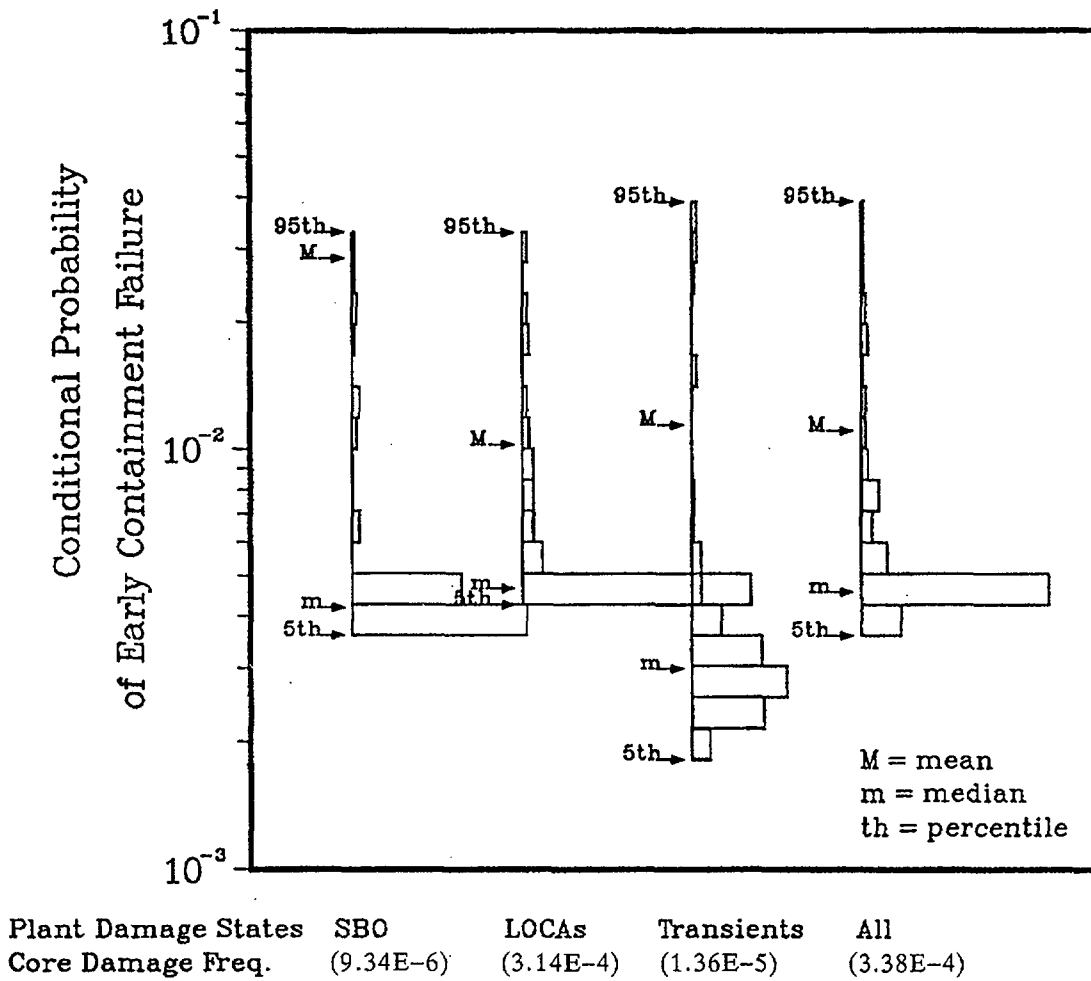

Figure 7.4 Conditional probability distributions for early containment failure at Zion.

state frequency-weighted average,* the mean conditional probabilities from internal events of (1) early containment failure from a combination of in-vessel steam explosions, overpressurization, and containment isolation failures is 0.014, (2) late containment failure, mainly from basemat meltthrough is 0.24, (3) containment bypass from interfacing-system LOCA and induced steam generator tube rupture (SGTR) is 0.006, and (4) probability of no containment failure is 0.73. Figure 7.4 further displays the conditional probability distributions of early containment failure for the plant damage states, thereby providing the estimated range of uncertainties in these containment failure predictions. The principal conclusion to be drawn from the information in Figures 7.3 and 7.4 is that the probability of early containment failure for Zion is low, i.e., 1 to 2 percent.

Additional discussion on containment performance is provided in Chapter 9.

7.3.2 Important Plant Characteristics (Containment Performance)

Characteristics of the Zion design and operation that are important to containment performance include:

1. Containment Volume and Pressure Capability

The combined magnitude of Zion's containment volume and estimated failure pressure provide considerable capability to withstand severe accident threats.

2. Reactor Cavity Geometry

The Zion containment design arrangement has a large cavity directly beneath the reactor pressure vessel that communicates to the lower containment by means of an instrument tunnel. Provided the contents of the refueling water storage tank have been injected prior to vessel breach, this arrangement should provide a mechanism for quenching the molten core for some severe accidents (although there remains some uncertainties with respect to the coolability of molten core debris in such circumstances).

*Each value in the column in Figure 7.3 labeled "All" is a frequency-weighted average obtained by calculating the products of individual accident progression bin conditional probabilities for each plant damage state and the ratio of the frequency of that plant damage state to the total core damage frequency.

7.4 Source Term Analysis

7.4.1 Results of Source Term Analysis

The containment performance results for the Zion (large, dry containment) plant and the Surry (sub-atmospheric containment) plant are quite similar. The source terms for analogous accident progression bins are also quite similar. Figure 7.5 illustrates the source term for early containment failure. As at Surry, the source terms for early failure are somewhat less than those for containment bypass. Within the range of the uncertainty band, however, the source terms from early containment failure are potentially large enough to result in some early fatalities.

The most likely outcome of a severe accident at the Zion plant is that the containment would not fail. Figure 7.6 illustrates the range of source terms for the no containment failure accident progression bin. Other than for the noble gas and iodine radionuclide groups, the entire range of source terms is below a release fraction of $10E-5$.

Additional discussion on source term perspectives is provided in Chapter 10.

7.4.2 Important Plant Characteristics (Source Term)

1. Containment Spray System

The containment spray system at the Zion plant is not required to operate to provide long-term cooling to the containment, in contrast to the Surry plant. Operation of the spray system is very effective, however, in reducing the airborne concentration of aerosols. Other than the release of noble gases and some iodine evolution, the release of radioactive material to the atmosphere resulting from late containment leakage or basemat meltthrough in which sprays have operated for an extended time would be very small. The source terms for the late containment failure accident progression bin are slightly higher than, but similar to, those of the no containment failure bin illustrated in Figure 7.6.

2. Cavity Configuration

The Zion cavity is referred to as a wet cavity, in that the accumulation of a relatively small amount of water on the containment floor will lead to overflow into the cavity. As a result, there is a substantial likelihood of eliminating by forming a coolable debris bed or

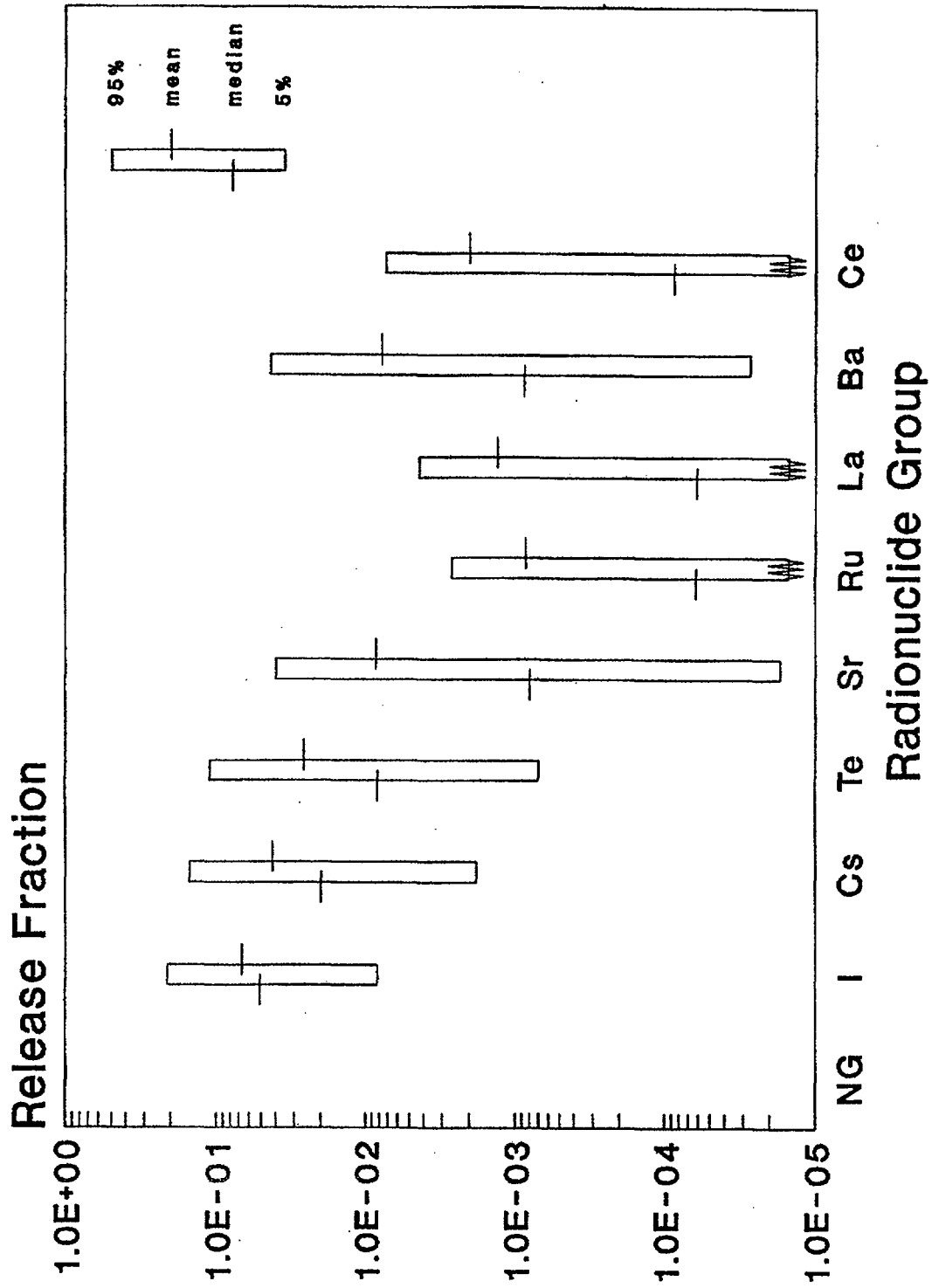

Figure 7.5 Source term distributions for early containment failure at Zion.

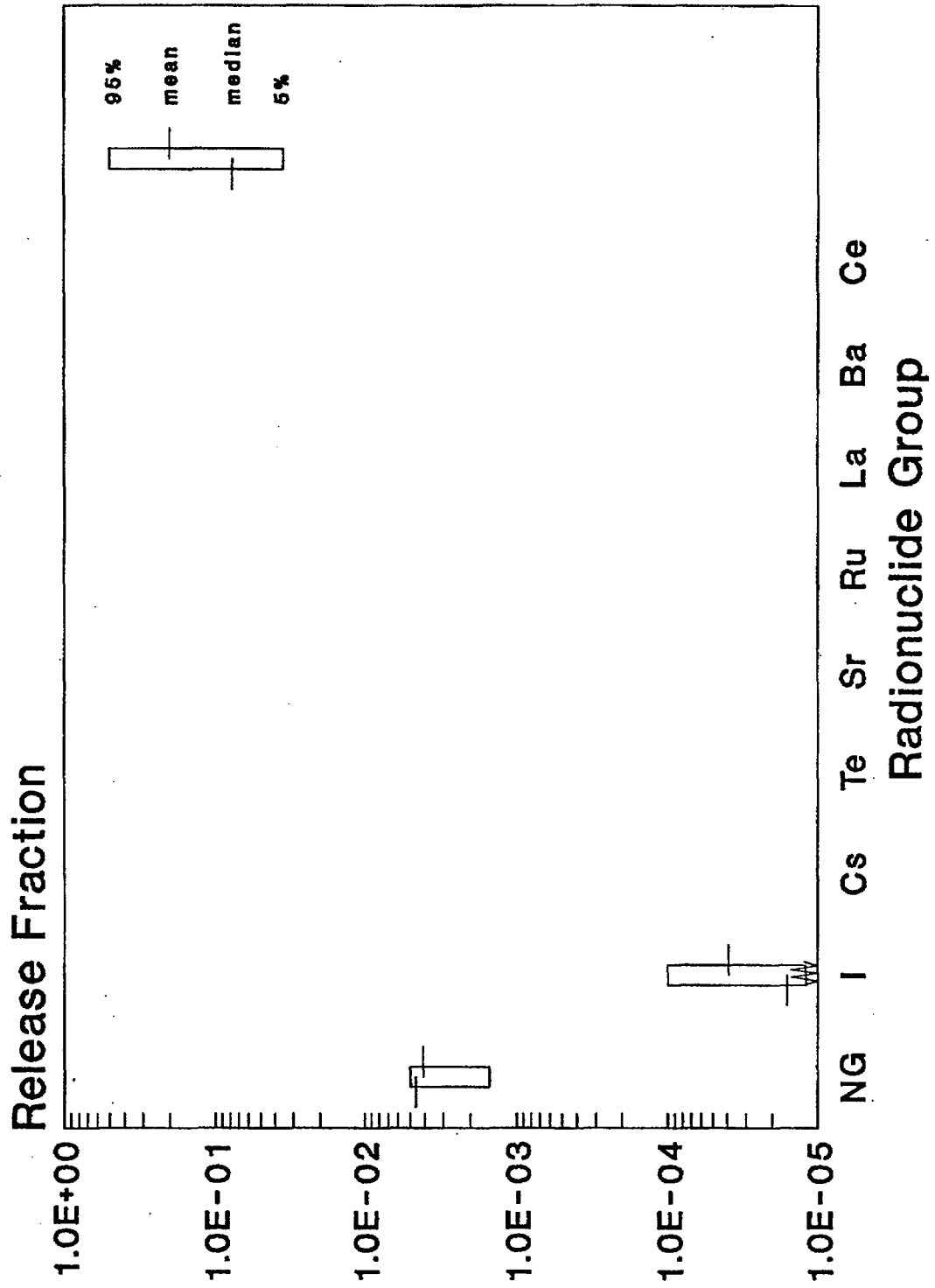

Figure 7.6 Source term distributions for no containment failure at Zion.

7. Zion Plant Results

mitigating by the presence of an overlaying pool of water the release of radionuclides from core-concrete interactions.

7.5 Offsite Consequence Results

Figure 7.7 displays the frequency distributions in the form of graphical plots of the complementary cumulative distribution functions (CCDFs) of four offsite consequence measures—early fatalities, latent cancer fatalities, and the 50-mile region and entire site region population exposures (in person-rems). These CCDFs include contributions from all source terms associated with reactor accidents caused by internal initiating events. Four CCDFs, namely, the 5th percentile, 50th percentile (median), 95th percentile, and the mean CCDFs are shown for each consequence measure.

Zion plant-specific and site-specific parameters were used in the consequence analysis for these CCDFs. The plant-specific parameters included source terms and their frequencies, the licensed thermal power (3250 MWt) of the reactor, and the approximate physical dimensions of the power plant building complex. The site-specific parameters included exclusion area radius (400 meters), meteorological data for 1 full year collected at the site meteorological tower, the site region population distribution based on the 1980 census data, topography (fraction of the area which is land—the remaining fraction is assumed to be water), land use, agricultural practice and productivity, and other economic data for up to 1,000 miles from the Zion plant.

The consequence estimates displayed in these figures have incorporated the benefits of the following protective measures: (1) evacuation of 99.5 percent of the population within the 10-mile plume exposure pathway emergency planning zone (EPZ), (2) early relocation of the remaining population only from the heavily contaminated areas both within and outside the 10-mile EPZ, and (3) decontamination, temporary interdiction, or condemnation of land, property, and foods contaminated above acceptable levels.

The population density within the Zion 10-mile EPZ is about 1360 persons per square mile. About 45 percent of the 10-mile EPZ is water. The average delay time before evacuation (after a warning prior to radionuclide release) from the 10-mile EPZ and average effective evacuation speed used in the analyses were derived from information contained in a utility-sponsored Zion evacuation time estimate study (Ref. 7.7) and in

an independent analysis by the Federal Emergency Management Agency (Ref. 7.8) and the NRC requirements for emergency planning.

The results displayed in Figure 7.7 are discussed in Chapter 11.

7.6 Public Risk Estimates

7.6.1 Results of Public Risk Estimates*

A detailed description of the results of the Zion risk analysis is provided in Reference 7.2. For this summary report, results are provided for the following measures of public risk:

- Early fatality risk,
- Latent cancer fatality risk,
- Population dose within 50 miles of the site,
- Population dose within the entire site region,
- Individual early fatality risk in the population within 1 mile of the Zion exclusion area boundary, and
- Individual latent cancer fatality risk in the population within 10 miles of the Zion site.

The first four of the above measures are commonly used measures in nuclear plant risk studies. The last two are those used to compare with the NRC safety goals (Ref. 7.9).

The results of the Zion risk analyses are shown in Figures 7.8 through 7.10. The figures display variabilities in mean risks estimated from the meteorology-based conditional mean values of the consequence measures. The risk estimates are slightly higher than those of the other two PWR plants (Surry and Sequoyah) in this study. Individual early and latent cancer fatality risks are well below the NRC safety goals. Detailed comparisons of results are given in Chapter 12.

The risk results shown in Figure 7.8 have been analyzed to identify the principal contributors (accident sequences and containment failure modes) to plant risk. These results are presented in Figures 7.11 and 7.12. As may be seen, both for early and latent cancer fatality risks, the dominant plant damage state is loss-of-coolant-accident (LOCA) sequences, which have the highest relative frequency and relatively high release fractions. Zion plant risks are dominated by early containment failure (alpha-mode failure, containment isolation failure, and overpressurization

*As noted in Section 7.2, sensitivity studies have been performed to reflect recent modifications in the Zion plant. The impact on risk is displayed on the figures in this section. More detailed discussion on the sensitivity studies may be found in Section C.15 of Appendix C.

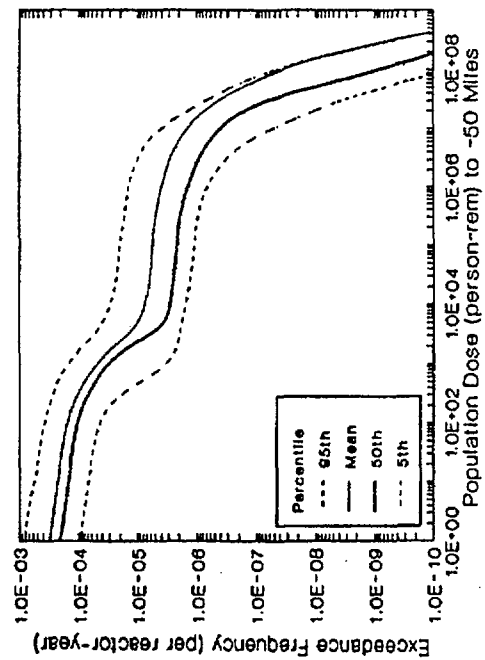
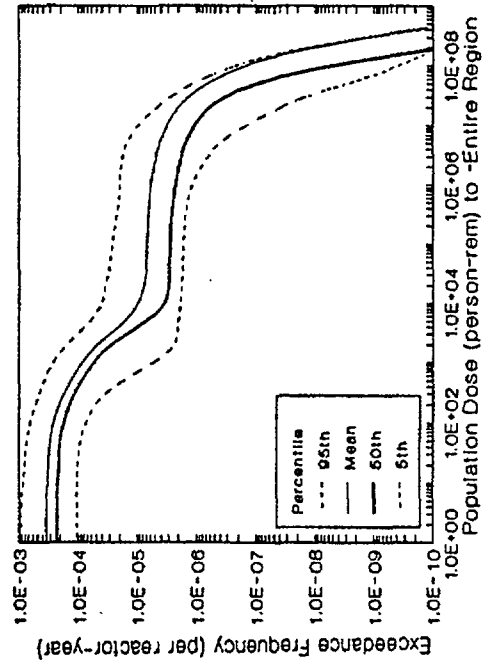
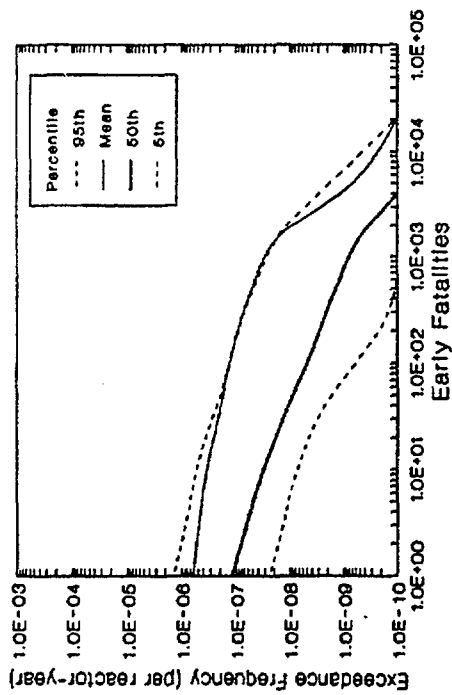
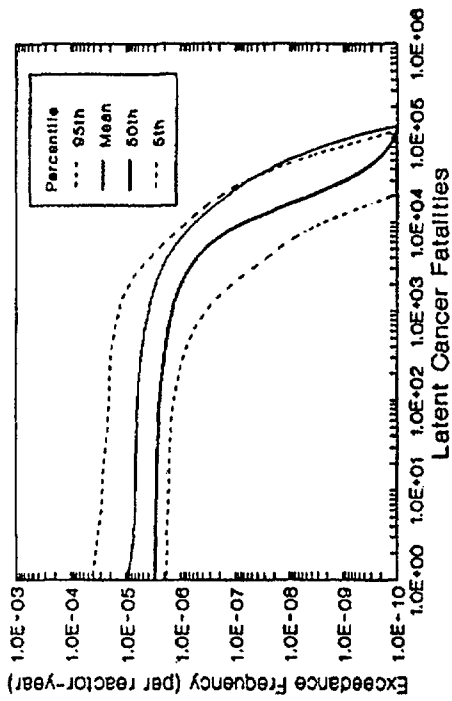

Note: As discussed in Reference 7.6, estimated risks at or below $1E-7$ per reactor year should be viewed with caution because of the potential impact of events not studied in the risk analyses.

Figure 7.7 Frequency distributions of offsite consequence measures at Zion (internal initiators).

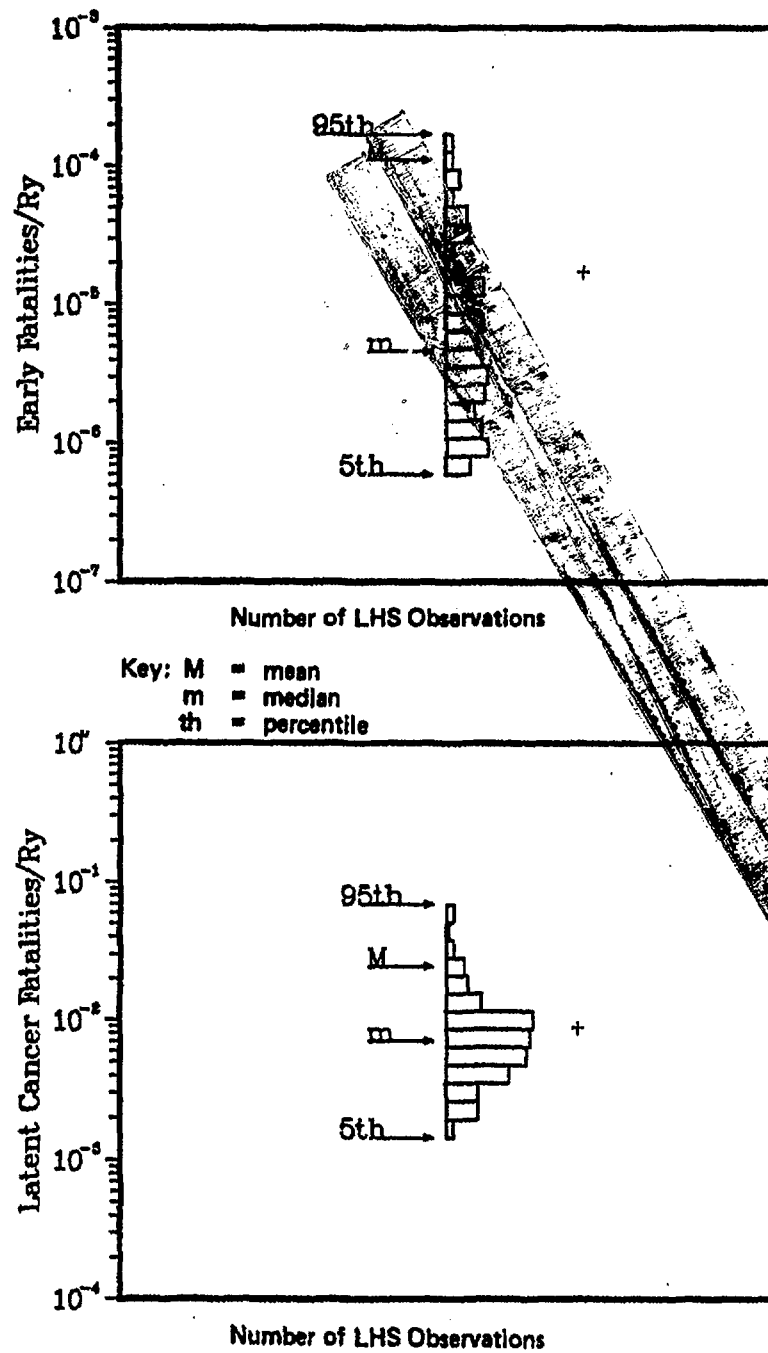

Notes As discussed in Reference 7.6, estimated risks at or below $1E-7$ per reactor year should be viewed with caution because of the potential impact of events not studied in the risk analyses.

"+" shows recalculated mean value based on plant modifications discussed in Section 7.2.1.

Figure 7.8 Early and latent cancer fatality risks at Zion (internal initiators).

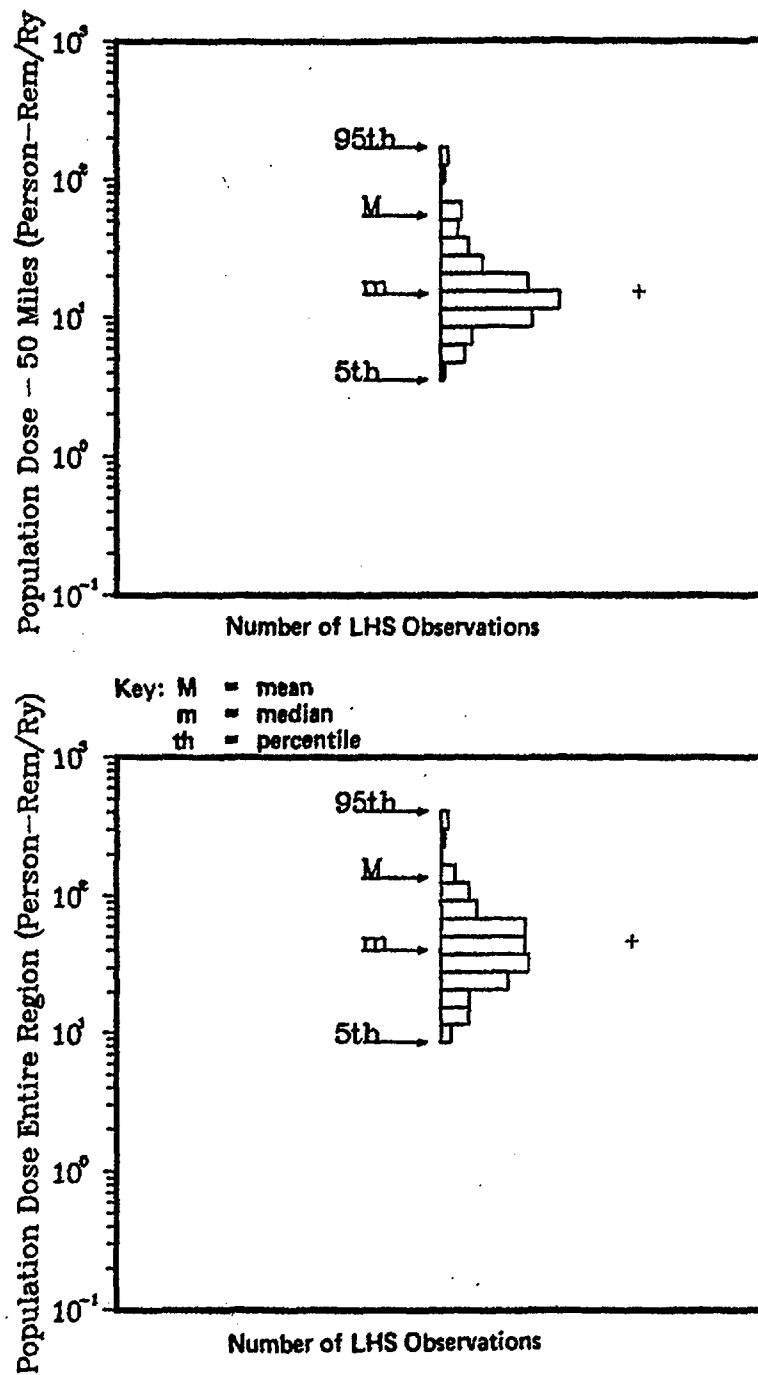

Notes: As discussed in Reference 7.6, estimated risks at or below $1E-7$ per reactor year should be viewed with caution because of the potential impact of events not studied in the risk analyses.

“+” shows recalculated mean value based on plant modifications discussed in Section 7.2.1.

Figure 7.9 Population dose risks at Zion (internal initiators).

7. Zion Plant Results

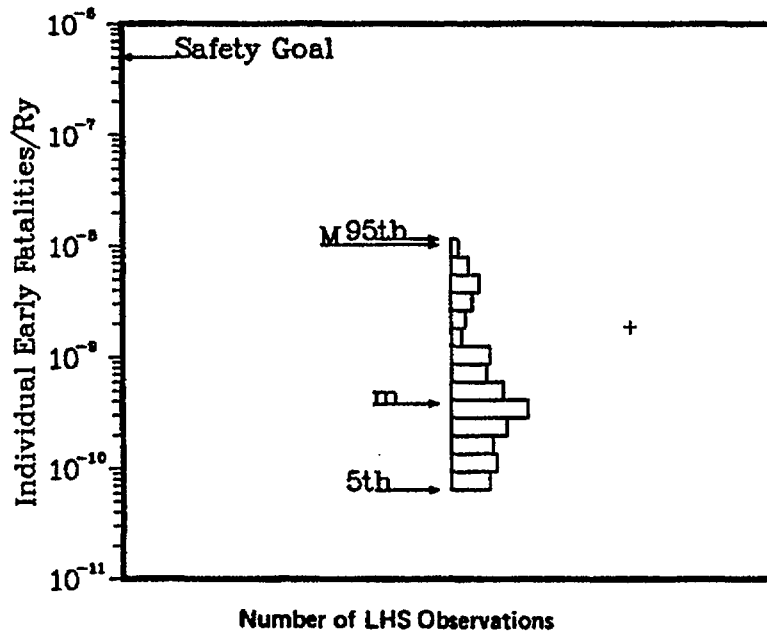

Key: M = mean
 m = median
 th = percentile

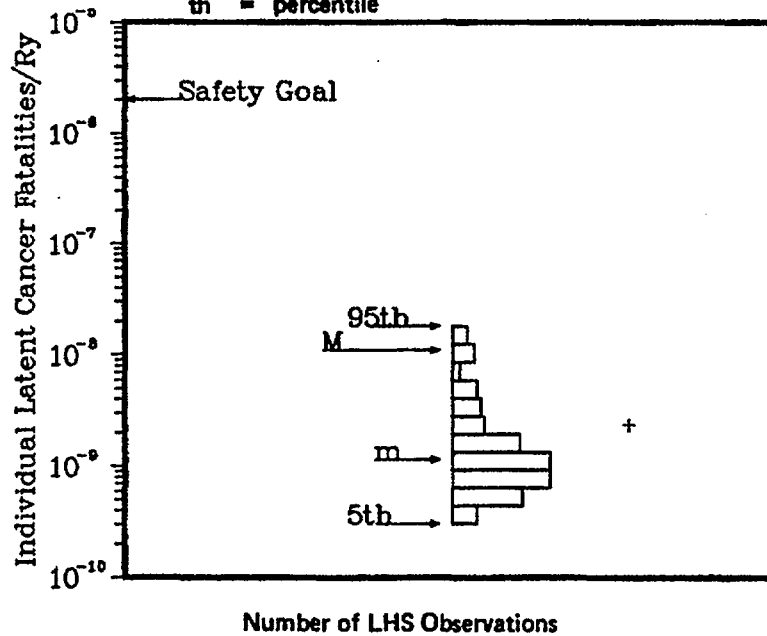

Notes: As discussed in Reference 7.6, estimated risks at or below 1E-7 per reactor year should be viewed with caution because of the potential impact of other health effects not studied in the risk analyses.

“+” shows recalculated mean value based on plant modifications discussed in Section 7.2.1.

Figure 7.10 Individual early and latent cancer fatality risks at Zion (internal initiators).

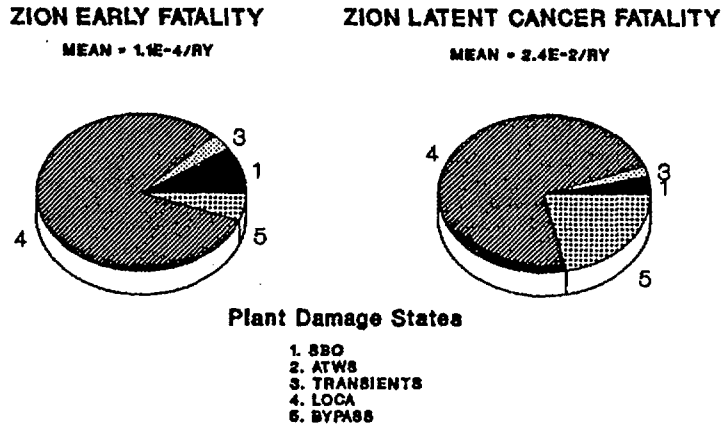

Figure 7.11 Major contributors (plant damage states) to mean early and latent cancer fatality risks at Zion (internal initiators).

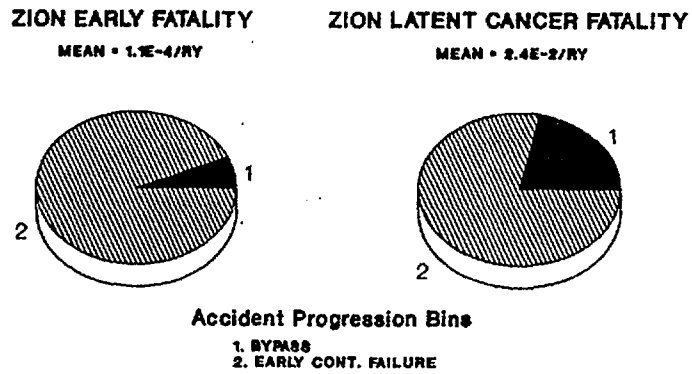

Figure 7.12 Major contributors (accident progression bins) to mean early and latent cancer fatality risks at Zion (internal initiators).

7. Zion Plant Results

failure). This occurs because, although the conditional probability of early failure is low, other failure modes have even lower probabilities.

7.6.2 Important Plant Characteristics (Risk)

- As discussed before, the dominant risk contributor for the Zion plant is early containment failure. The accident progression bin for early containment failure contains several failure modes such as the alpha-mode, containment isolation, and overpressurization failures.
- The containment structure at Zion is robust, with a low probability of failure. This has led to the low risk estimates from the Zion plant. (In comparison with other plants studied in this report, risks from Zion are relatively high; but, in the absolute sense, the risks are very low and well below the NRC safety goals.)

REFERENCES FOR CHAPTER 7

- 7.1 M. B. Sattison and K. W. Hall, "Analysis of Core Damage Frequency: Zion Unit 1," Idaho National Engineering Laboratory, NUREG/CR-4550, Vol. 7, Revision 1, EGG-2554, May 1990.
- 7.2 C. K. Park et al., "Evaluation of Severe Accident Risks: Zion Unit 1," Brookhaven National Laboratory, NUREG/CR-4551, Vol. 7, Draft Revision 1, BNL-NUREG-52029, to be published.*
- 7.3 D. L. Berry et al., "Review and Evaluation of the Zion Probabilistic Safety Study: Plant Analysis," Sandia National Laboratories, NUREG/CR-3300, Vol. 1, SAND83-1118, May 1984.
- 7.4 Cordell Reed, Commonwealth Edison Co. (CECo), "Zion Station Units 1 and 2. Commitment to Provide a Backup Water Source to the Charging Oil Coolers," NRC Docket Nos. 50-295 and 50-304, March 13, 1989.
- 7.5 R. A. Chrzanowski, CECo, "March 13, 1989 Letter from Cordell Reed to T. E. Murley," NRC, NRC Docket Nos. 50-295 and 50-304, August 24, 1990.
- 7.6 H. J. C. Kouts et al., "Special Committee Review of the Nuclear Regulatory Commission's Severe Accident Risks Report (NUREG-1150)," NUREG-1420, August 1990.
- 7.7 Stone & Webster Engineering Corporation, "Preliminary Evacuation Time Study of the 10-Mile Emergency Planning Zone at the Zion Station," prepared for Commonwealth Edison Company, January 1980.
- 7.8 Federal Emergency Management Agency, "Dynamic Evacuation Analyses: Independent Assessments of Evacuation Times from the Plume Exposure Pathway Emergency Planning Zones of Twelve Nuclear Power Stations," December 1980.
- 7.9 USNRC, "Safety Goals for the Operation of Nuclear Power Plants; Policy Statement," *Federal Register*, Vol. 51, p. 30028, August 21, 1986.

*Available in the NRC Public Document Room, 2120 L Street NW., Washington, DC.

PART III

Perspectives and Uses

8. PERSPECTIVES ON FREQUENCY OF CORE DAMAGE

8.1 Introduction

Chapters 3 through 7 have summarized the core damage frequencies individually for the five plants assessed in this study. Significant differences among the plants can be seen in the results, both in terms of the core damage frequencies and the particular events that contribute most to those frequencies. These differences are due to plant-specific differences in the plant designs and operational practices. Despite the plant-specific nature of the study, it is possible to obtain important perspectives that may have implications for a larger number of plants and also to describe the types of plant-specific features that are likely to be important at other plants. This chapter provides some of these perspectives.

8.2 Summary of Results

As discussed in Chapter 2, the core damage frequency is not a value that can be calculated with absolute certainty and thus is best characterized by a probability distribution. It is therefore discussed in this report in terms of the mean, median, and various percentile values. The internal-event core damage frequencies are illustrated graphically in Figure 8.1 (Refs. 8.1 through 8.5). The figure does not include the contributions of external events, which are discussed in Section 8.4.

In Figure 8.1 the lower and upper extremities of the bars represent the 5th and 95th percentiles of the distributions, with the mean and median of each distribution also shown. Thus, the bars include the central 90 percent of the distributions (it should be remembered that the distributions are not uniform within these bars). These figures show that the range between the 5th and 95th percentiles covers from one to two orders of magnitude for the five plants. There is also significant overlap among the distributions, as discussed below. The reader should refer to References 8.1 through 8.5 for detailed discussion of the distributions.

Figures 8.2 and 8.3 show the contributions of the principal types of accidents to the mean core damage frequency for each plant. Figure 8.4 also presents this breakdown, but on a relative scale. These figures show that some types of accidents, such as station blackouts, contribute to the core damage frequencies for all the plants; however,

there is substantial plant-to-plant variability among important accident sequences.

Figures 8.5 through 8.8 provide the results of the external-event analyses, and Figures 8.9 through 8.12 give the breakdown of these analyses according to the principal types of accident sequences.

8.3 Comparison with Reactor Safety Study

Figures 8.13 and 8.14 show the internal core damage frequency distributions calculated in this present study for Surry and Peach Bottom along with distributions synthesized from the Reactor Safety Study (Ref. 8.6), which also analyzed Surry and Peach Bottom. The Reactor Safety Study presented results in terms of medians but not means. It can be seen that the medians are lower in the present work, although observation of the overlap of the ranges shows that the change is more significant for Peach Bottom than for Surry.

There are two important reasons for the differences between the new figures and those of the Reactor Safety Study. The first is the fact that probabilistic risk analyses (PRAs) are snapshots in time. In these cases, the snapshots are taken about 15 years apart. Both plants have implemented hardware modifications and procedural improvements with the stated purpose of increasing safety, which drives core damage frequencies downward.

The second reason is that the state of the art in applying probabilistic analysis in nuclear power plant applications has advanced significantly since the Reactor Safety Study was performed. Computational techniques are now more sophisticated, computing power has increased enormously, and consequently the level of detail in modeling has increased. In some cases, these new methods have reduced or eliminated previous analytical conservatism. However, new types of failures have also been discovered. For example, the years of experience with probabilistic analyses and plant operation have uncovered the reactor coolant pump seal failure scenario as well as intersystem dependencies, common-mode failure mechanisms, and other items that were less well recognized at the time of the Reactor Safety Study. Of course, this same experience has also uncovered new ways in which recovery can be achieved during the course of a possible core damage scenario (except for the

8. Core Damage Frequency

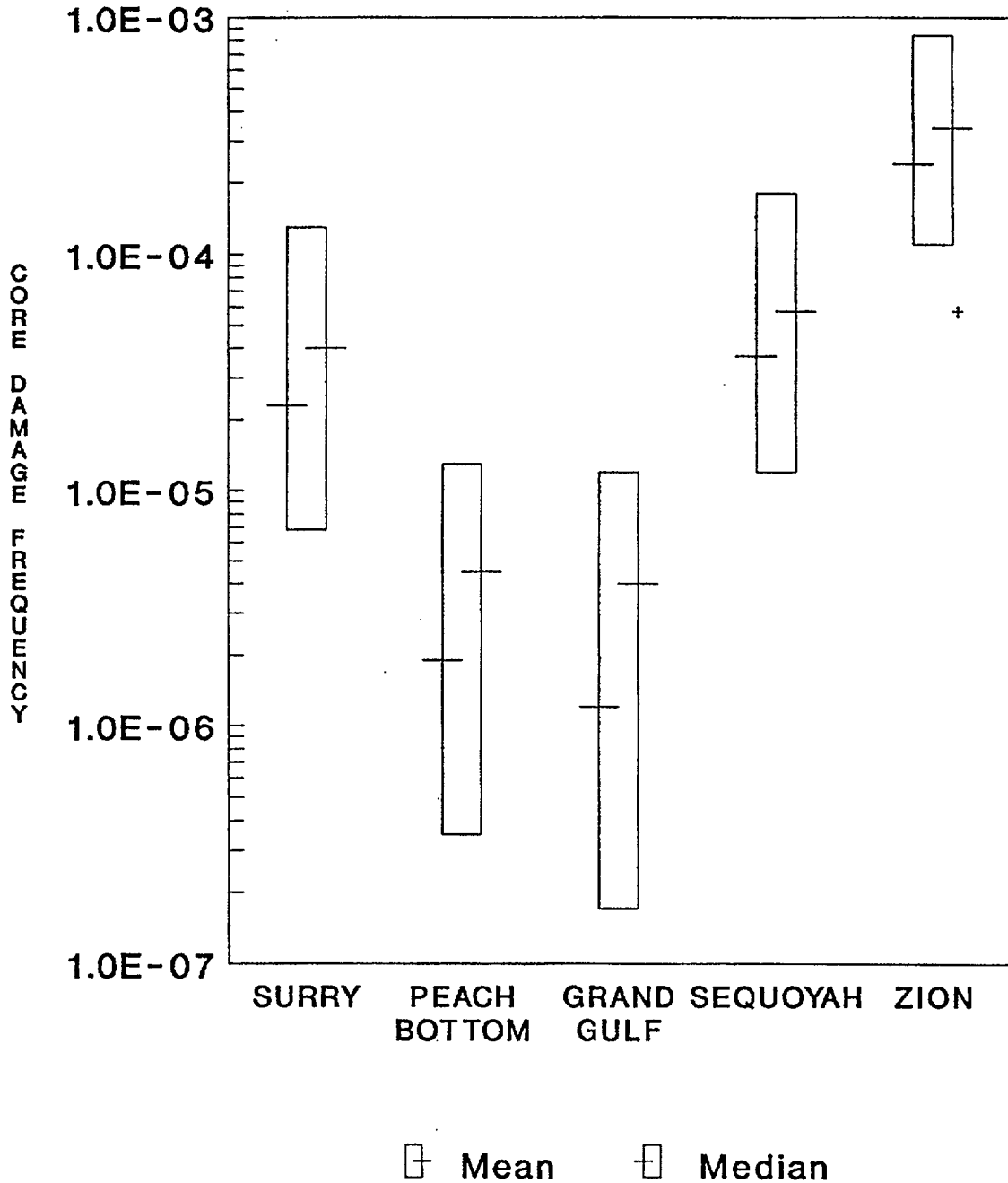

Notes: As discussed in Reference 8.7, core damage frequencies below 1E-5 per reactor year should be viewed with caution because of the remaining uncertainties in PRA (e.g., events not considered).

“+” indicates recalculated Zion mean core damage frequency based on recent plant modifications (see Section 7.2.1).

Figure 8.1 Internal core damage frequency ranges (5th to 95th percentiles).

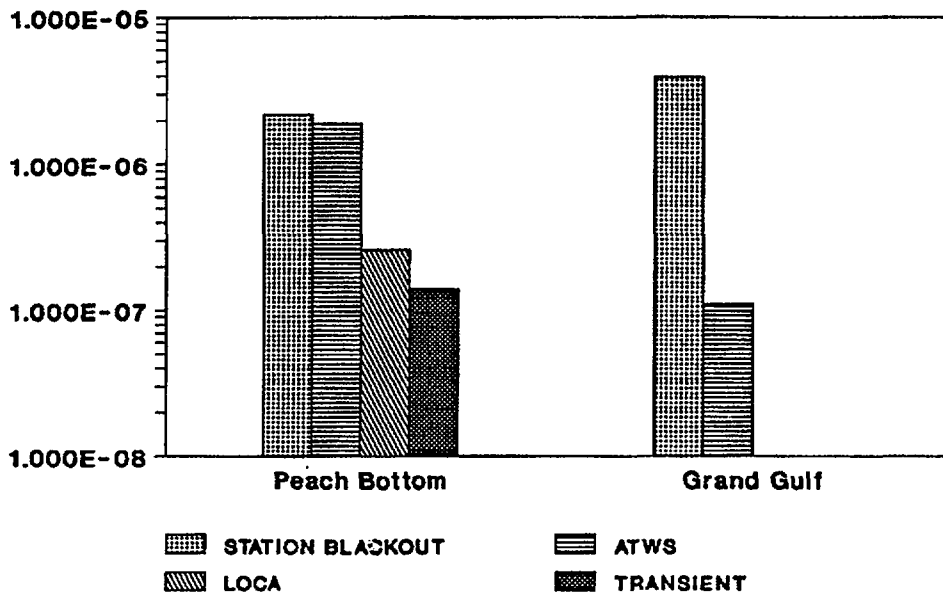
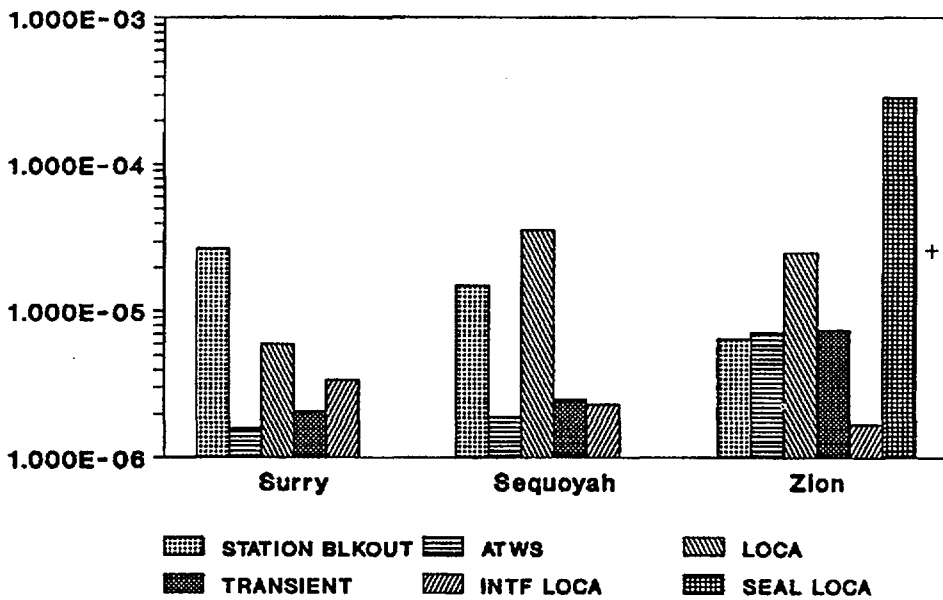

Figure 8.2 BWR principal contributors to internal core damage frequencies.



Notes: As discussed in Reference 8.7, core damage frequencies below 1E-5 per reactor year should be viewed with caution because of the remaining uncertainties in PRA (e.g., events not considered).

“+” indicates recalculated mean seal LOCA plant damage state frequency based on recent plant modifications (see Section 7.2.1).

Figure 8.3 PWR principal contributors to internal core damage frequencies.

8. Core Damage Frequency

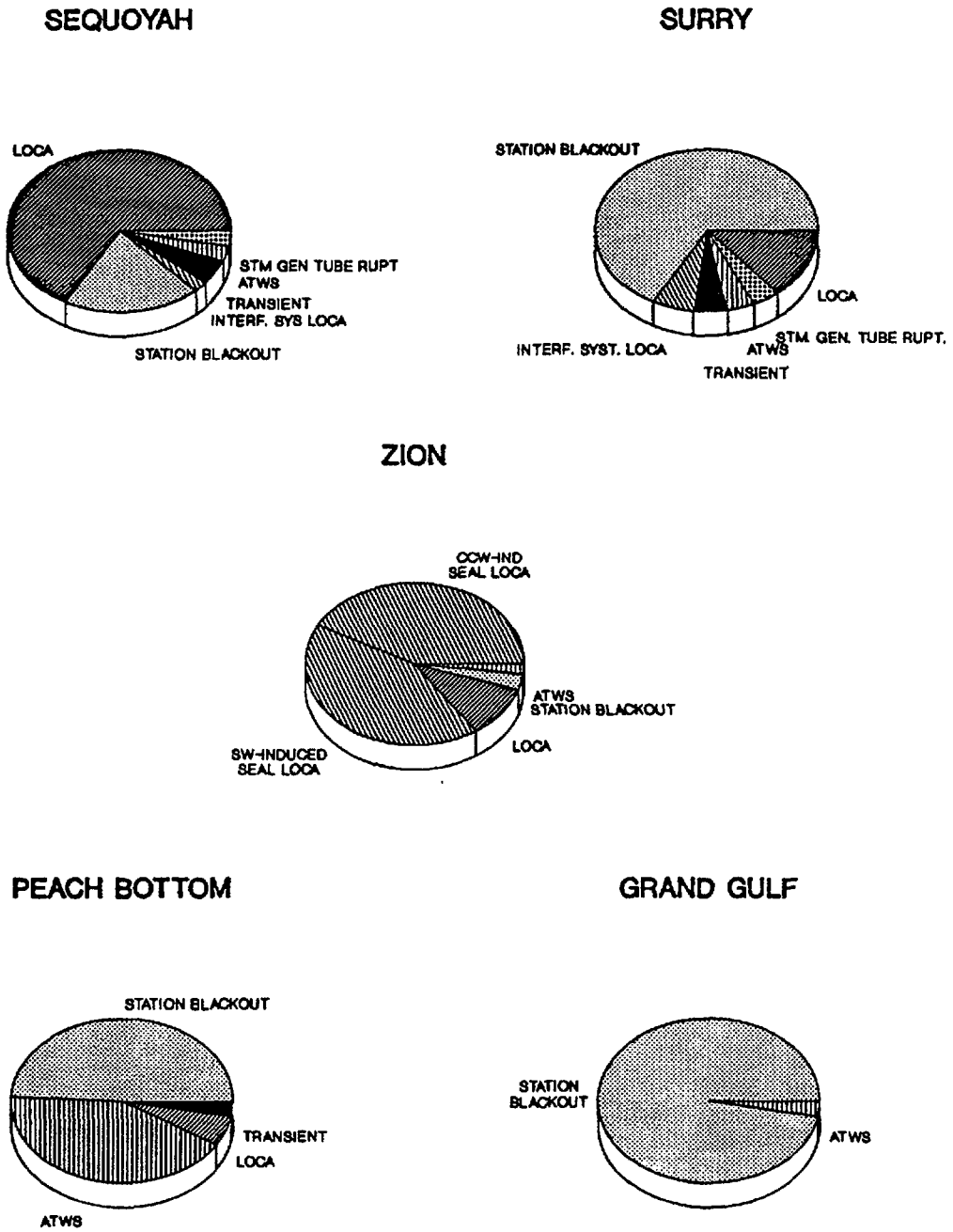

Figure 8.4 Principal contributors to internal core damage frequencies.

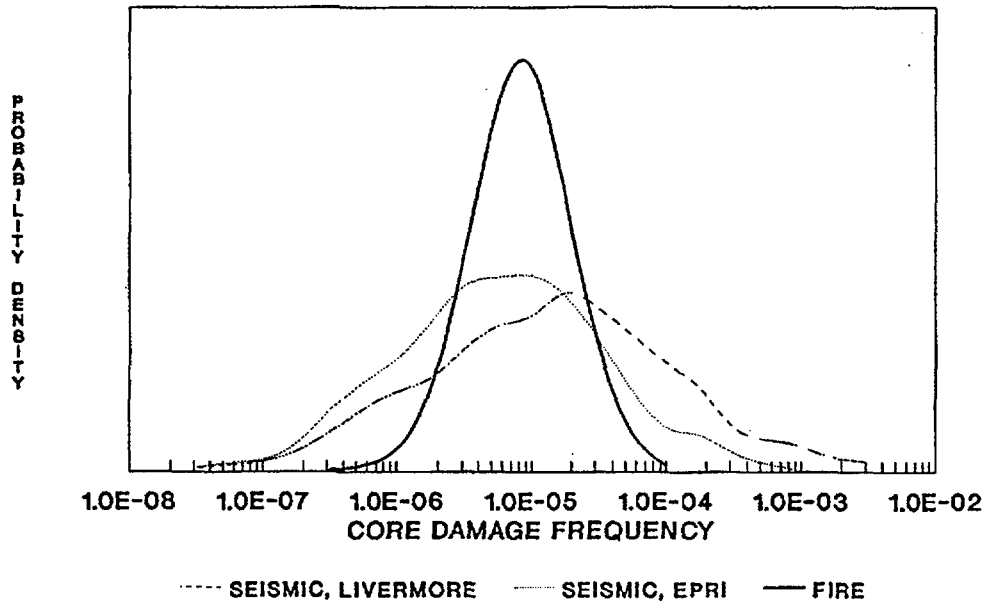
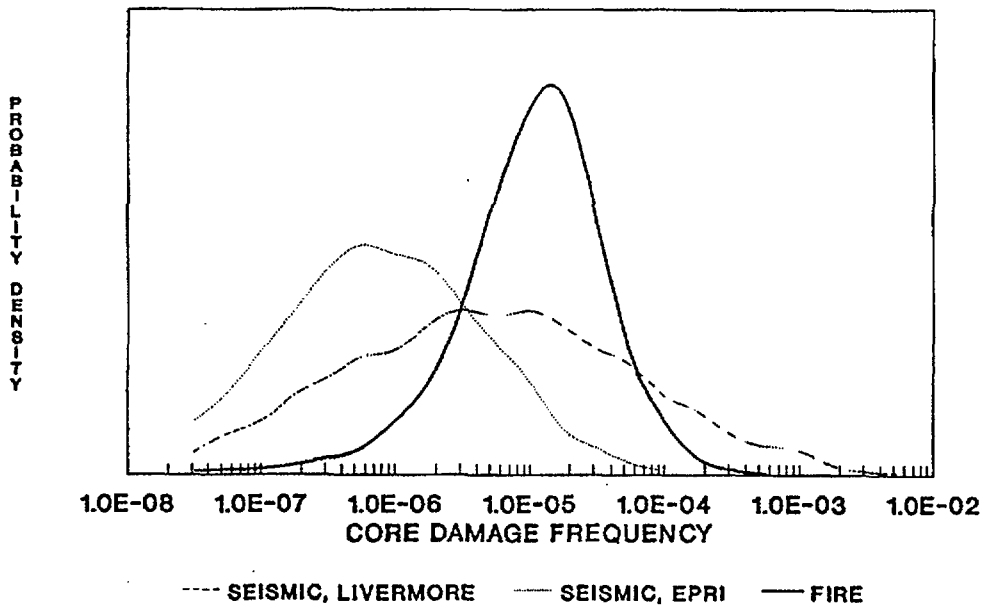

Figure 8.5 Surry external-event core damage frequency distributions.



Note: As discussed in Reference 8.7, core damage frequencies below $1E-5$ per reactor year should be viewed with caution because of the remaining uncertainties in PRA (e.g., events not considered).

Figure 8.6 Peach Bottom external-event core damage frequency distributions.

8. Core Damage Frequency

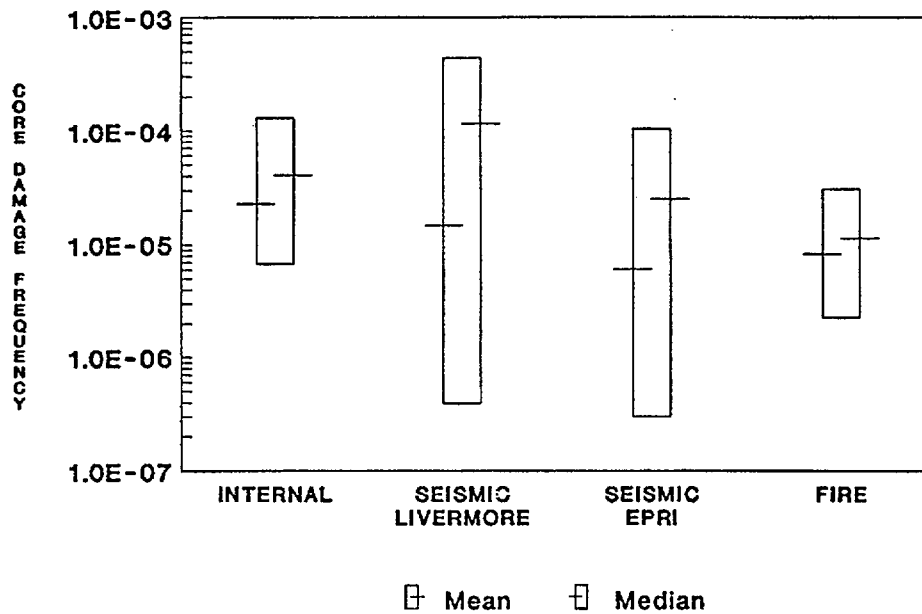
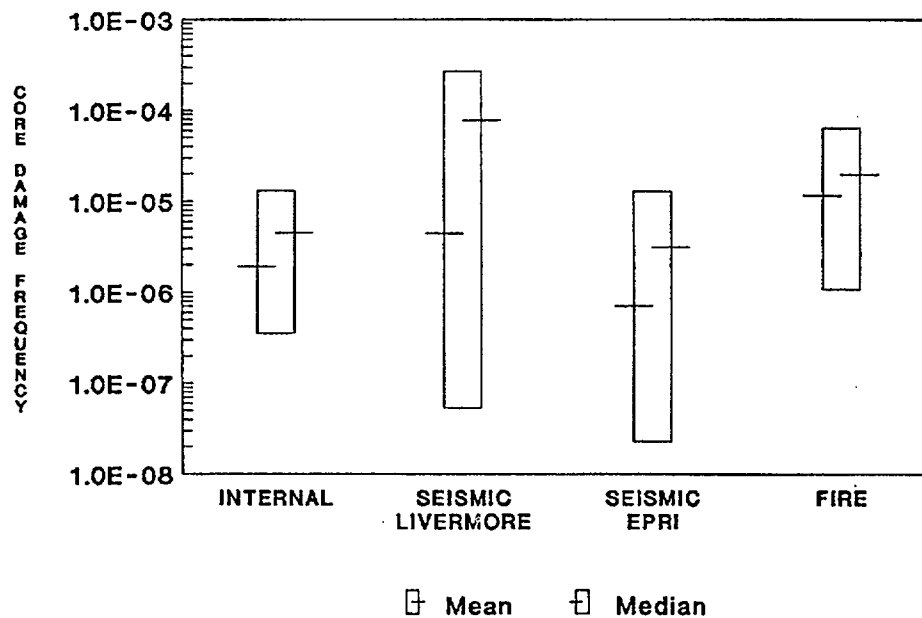

Figure 8.7 Surry internal- and external-event core damage frequency ranges.



Note: As discussed in Reference 8.7, core damage frequencies below $1E-5$ per reactor year should be viewed with caution because of the remaining uncertainties in PRA (e.g., events not considered).

Figure 8.8 Peach Bottom internal- and external-event core damage frequency ranges.

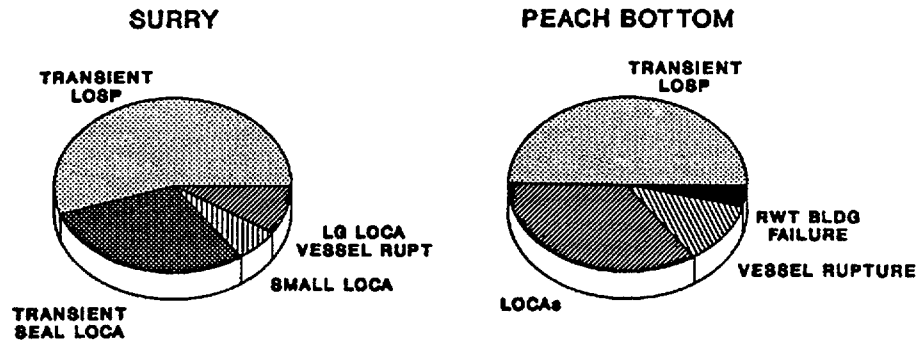

Figure 8.9 Principal contributors to seismic core damage frequencies.

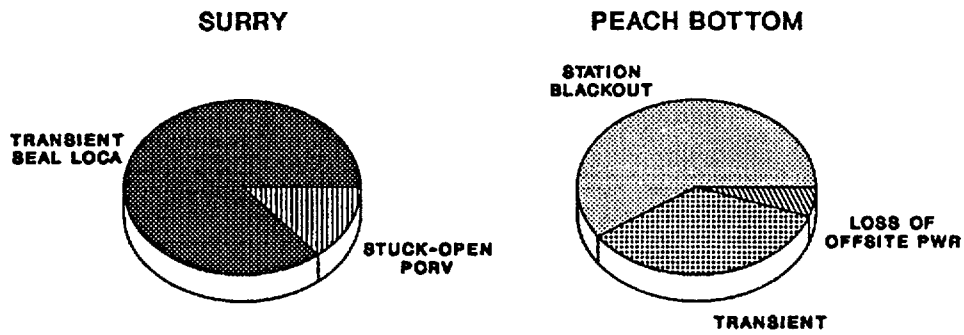

Figure 8.10 Principal contributors to fire core damage frequencies.

8. Core Damage Frequency

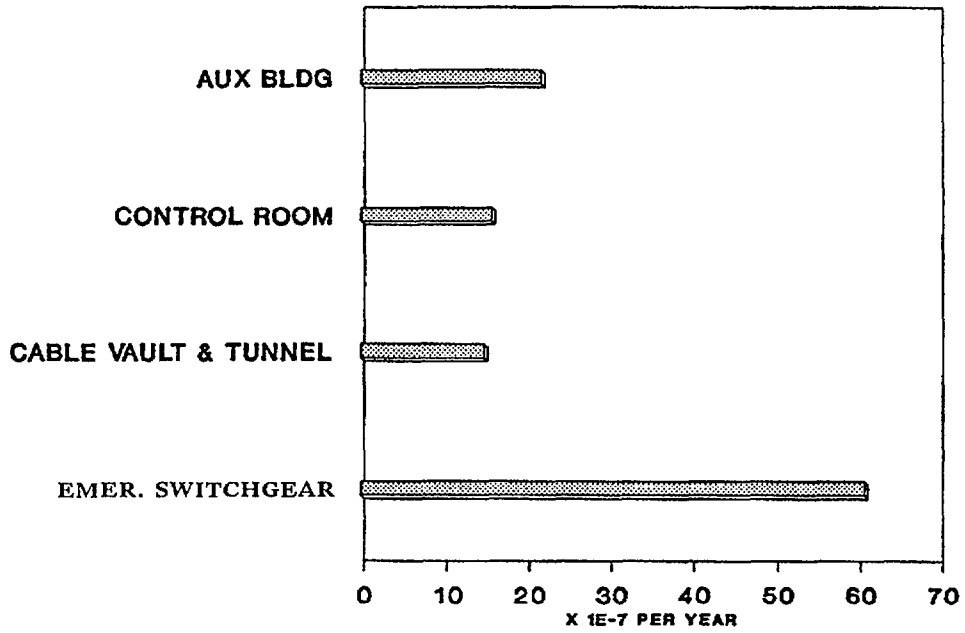
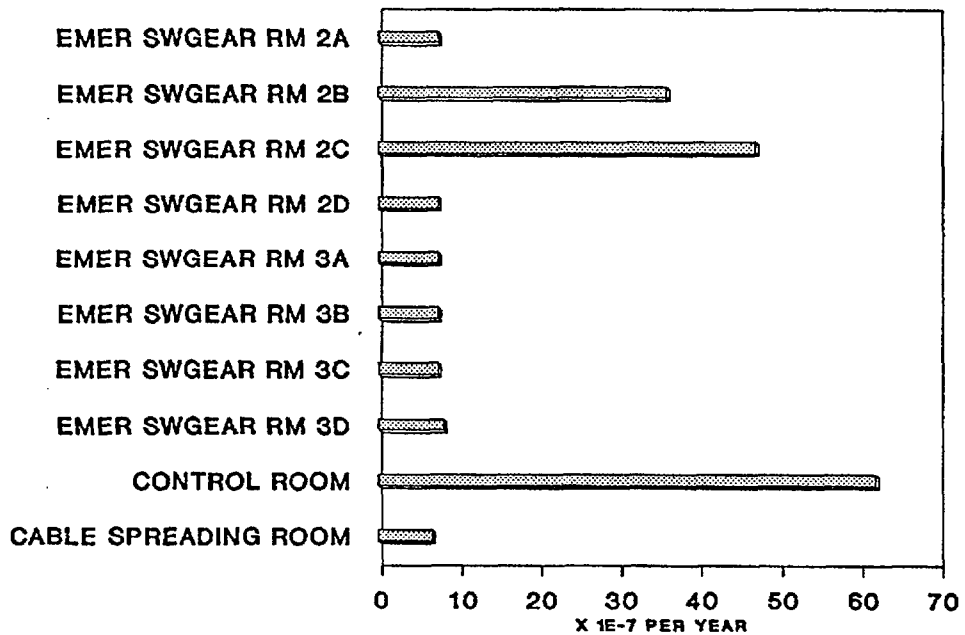

Figure 8.11 Surry mean fire core damage frequency by fire area.



Note: As discussed in Reference 8.7, core damage frequencies below $1E-5$ per reactor year should be viewed with caution because of the remaining uncertainties in PRA (e.g., events not considered).

Figure 8.12 Peach Bottom mean fire core damage frequency by fire area.

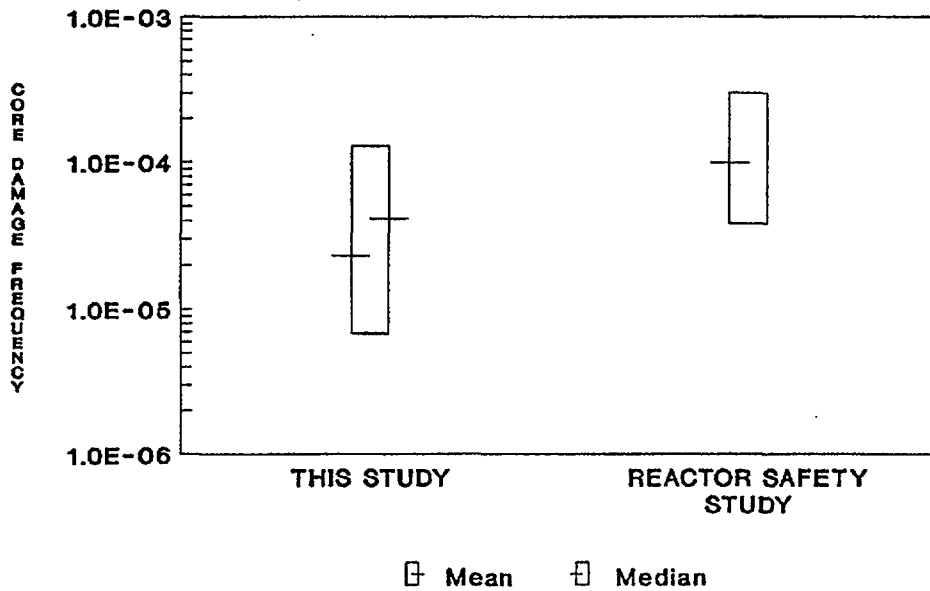
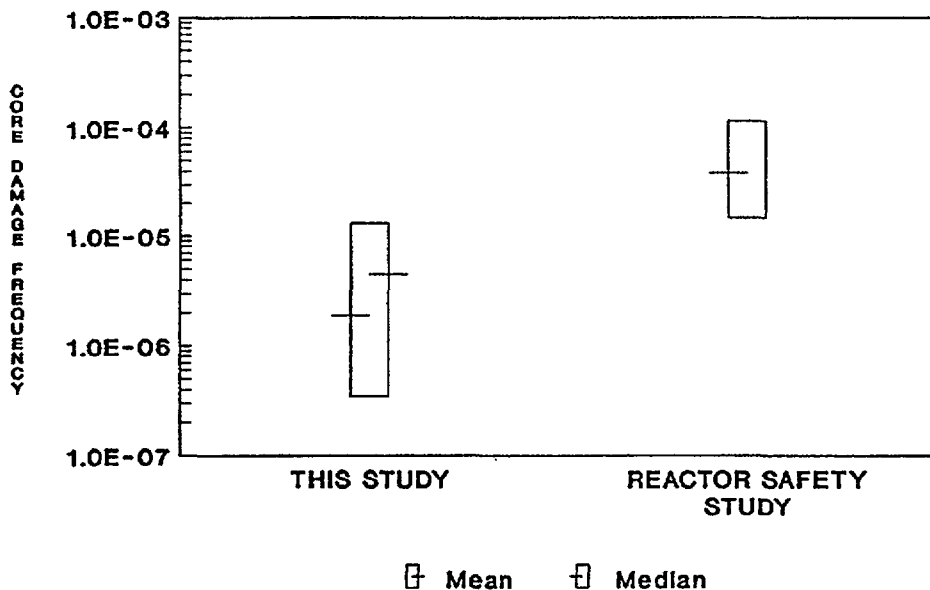

Figure 8.13 Comparison of Surry internal core damage frequency with Reactor Safety Study.



Note: As discussed in Reference 8.7, core damage frequencies below 1E-5 per reactor year should be viewed with caution because of the remaining uncertainties in PRA (e.g., events not considered).

Figure 8.14 Comparison of Peach Bottom internal core damage frequency with Reactor Safety Study.

8. Core Damage Frequency

recovery of ac power, the Reactor Safety Study did not consider recovery actions). Thus, the net effect of including these new techniques and experience is plant specific and can shift core damage frequencies in either higher or lower directions.

In the case of the Surry analysis, the Reactor Safety Study found the core damage frequency to be dominated by loss-of-coolant accidents (LOCAs). For the present study, station blackout accidents are dominant, while the LOCA-induced core damage frequency is substantially reduced from that of the Reactor Safety Study, particularly for the small LOCA events. This occurred in spite of a tenfold increase in the small LOCA initiating event frequency estimates, which was a result of the inclusion of reactor coolant pump seal failures. One reason for the reduction lies in plant modifications made since the Reactor Safety Study was completed. These modifications allow for the crossconnection of the high-pressure safety injection systems, auxiliary feedwater systems, and refueling water storage tanks between the two units at the Surry site. These crossties provide a reliable alternative for recovery of system failures. Thus, the plant modifications (the crossconnections) have driven the core damage frequencies downward, but new PRA information (the higher small LOCA frequency) has driven them upward. In this case, the net effect is an overall reduction in the core damage frequency for internal events.

In the case of Peach Bottom, the Reactor Safety Study found the core damage frequency to be comprised primarily of ATWS accident sequences and of transients with long-term failure of decay heat removal. The present study concludes that station blackout scenarios are dominant. The possibility of containment venting and allowing for some probability of core cooling after containment failure has considerably reduced the significance of the long-term loss of decay heat removal accidents. In addition, the plant has implemented some ATWS improvements, although ATWS events remain among the dominant accident sequence types. Moreover, more modern neutronic and thermal-hydraulic simulations of the ATWS sequences have calculated lower core power levels during the event, allowing more opportunity for mitigation such as through the use of low-pressure injection systems. Thus, for Peach Bottom, both advances in PRA methodology and plant modifications have contributed to a reduction in the estimated core damage frequency from internal events.

In summary, there have been reductions in the core damage frequencies for both plants since the Reactor Safety Study. The reduction in core damage frequency for Peach Bottom is more significant than for Surry; however, there is still considerable overlap of the uncertainty ranges of the two studies. The conclusion to be drawn is that the hardware and procedural changes made since the Reactor Safety Study appear to have reduced the core damage frequency at these two plants, even when accounting for more accurate failure data and reflecting new sequences not identified in the Reactor Safety Study (e.g., the reactor coolant pump seal LOCA).

8.4 Perspectives

8.4.1 Internal-Event Core Damage Probability Distributions

The core damage frequencies produced by all PRAs inherently have large uncertainties. Therefore, comparisons of frequencies between PRAs or with absolute limits or goals are not simply a matter of comparing two numbers. It is more appropriate to observe how much of the probability distribution lies below a given point, which translates into a measure of the probability that the point has not been exceeded. For example, if the median were exactly equal to the point in question, half of the distribution would lie above and half below the point, and there would be a 50 percent probability that the point had not been exceeded.

Similarly, when comparing core damage frequencies calculated for two or more plants, it is not sufficient to simply compare the mean values of the probability distributions. Instead, one must compare the entire distribution. If one plant's distribution were almost entirely below that of another, then there would be a high probability that the first plant had a lower core damage frequency than the second. Seldom is this the case, however. Usually, the distributions have considerable overlap, and the probability that one plant has a higher or lower core damage frequency than another must be calculated. References 8.1 through 8.5 contain more detailed information on the distributions that would support such calculations.

Although the distributions are not compared in detail here, the overlap of such core damage frequency distributions is clearly shown in Figure 8.1. For example, one can have relatively high confidence that the internal-event core damage frequency for Grand Gulf is lower than that of Sequoyah or Surry. Conversely, it can readily be seen that the differences in core damage

frequency between Surry and Sequoyah are not very significant.

Interpretation of extremely low median or mean core damage frequencies ($<1E-5$) is somewhat difficult. As discussed in Section 1.3 and in Reference 8.7, there are limitations in the scope of the study that could lead to actual core damage frequencies higher than those estimated. In addition, the uncertainties in the sequences included in the study tend to become more important on a relative scale as the frequency decreases. A very low core damage frequency is evident for Grand Gulf with the median of the distribution in the range of $1E-6$ per reactor year. However, it is incomplete to simply state that the core damage frequency for this plant is that low since the 95th percentile exceeds $1E-5$ per reactor year. Thus, although the central tendency of the calculation is very low, there is still a finite probability of a higher core damage frequency, particularly when considering that the scope of the study does not include certain types of accidents as discussed in Section 1.3.

8.4.2 Principal Contributors to Uncertainty in Core Damage Frequency

In Section 8.4.3, analyses are discussed concerning some of the issues and events that contribute to the magnitude of the core damage frequency. Generally, for the accident frequency analysis, the issues that contribute most to the magnitude of the frequency are also the issues that contribute most to the estimated uncertainty. More detail concerning the contributions of various parameters to the uncertainty in core damage frequency may be found in References 8.1 through 8.5. Perspectives on the contributions of accident frequency issues to the uncertainty in risk may be found in Chapter 12.

8.4.3 Dominant Accident Sequence Types

The various accident sequences that contribute to the total core damage frequency can be grouped by common factors into categories. Older PRAs generally did this in terms of the initiating event, e.g., transient, small LOCA, large LOCA. Current practice also uses categories, such as ATWS, seal LOCA, and station blackout. Generally, these categories are not equal contributors to the total core damage frequency. In practice, four or five sequence categories, sometimes fewer, usually contribute almost all the core damage frequency. These will be referred to below as the dominant plant damage states (PDSs).

It should be noted that the selection of categories is not unique in a mathematical sense, but instead is a convenient way to group the results. If the core damage frequency is to be changed, changing something common to the dominant PDS will have the most effect. Thus, if a particular plant had a relatively high core damage frequency and a particular group of sequences were high, a valuable insight into that plant's safety profile would be obtained.

It should also be noted that the importance of the highest frequency accident sequences should be considered in relationship to the total core damage frequency. The existence of a highly dominant accident sequence or PDS does not of itself imply that a safety problem exists. For example, if a plant already had an extremely low estimated core damage frequency, the existence of a single, dominant PDS would have little significance. Similarly, if a plant were modified such that the dominant PDS were eliminated entirely, the next highest PDS would become the most dominant contributor.

Nevertheless, it is the study of the dominant PDS and the important failures that contribute to those sequences that provides understanding of why the core damage frequency is high or low relative to other plants and desired goals. This qualitative understanding of the core damage frequency is necessary to make practical use of the PRA results and improve the plants, if necessary.

Given this background, the dominant PDSs for the five studies are illustrated in Figures 8.2, 8.3, and 8.4. Additional discussion of these PDSs can be found in Chapters 3 through 7. Several observations on these PDSs and their effects on the core damage frequency can be made, as discussed below.

Boiling Water Reactor versus Pressurized Water Reactor

It is evident from Figure 8.1 that the two particular BWRs in this study have internal-event core damage frequency distributions that are substantially lower than those of the three PWRs. While it would be inappropriate to conclude that all BWRs have lower core damage frequencies than PWRs, it is useful to consider why the core damage frequencies are lower for these particular BWRs.

The LOCA sequences, often dominant in the PWR core damage frequencies, are minor contributors in the case of the BWRs. This is not surprising in view of the fact that most BWRs have many more systems than PWRs for injecting water

8. Core Damage Frequency

directly into the reactor coolant system to provide makeup. For BWRs, this includes two low-pressure emergency core cooling (ECC) systems (low-pressure coolant injection and low-pressure core spray), each of which is multitrain; two high-pressure injection systems (reactor core isolation cooling and either high-pressure coolant injection or high-pressure core spray); and usually several other alternative injection systems, such as the control rod drive hydraulic system, condensate, service water, firewater, etc. In contrast, PWRs generally have one high-pressure and one low-pressure ECC system (both multitrain), plus a set of accumulators. The PWR ECCS does have considerable redundancy, but not as much as that of most BWRs.

For many types of transient events, the above arguments also hold. BWRs tend to have more systems that can provide decay heat removal than PWRs. For transient events that lead to loss of water inventory due to stuck-open relief valves or primary system leakage, BWRs have numerous systems to provide makeup. ATWS events and station blackout events, as discussed below, affect both PWRs and BWRs.

BWRs have historically been considered more subject than PWRs to ATWS events. This perception was partly due to the fact that some ATWS events in a BWR involve an insertion of positive reactivity. Except for the infrequent occurrence of an unfavorable moderator temperature coefficient, an ATWS event in a PWR is slower, allowing more time for mitigative action.

In spite of this historical perspective for ATWS, it is evident from Figures 8.2 and 8.3 that the ATWS frequencies for the two BWRs are not dramatically higher than for the PWRs. There are several reasons for this. First, plant procedures for dealing with ATWS events have been modified over the past several years, and operator training specifically for these events has improved significantly. Second, the ability to model and analyze ATWS events has improved. More modern neutronic and thermal-hydraulic simulations of the ATWS sequences have calculated lower core power levels during the event than predicted in the past. Further, these calculations indicate that low-pressure injection systems can be used without resulting in significant power oscillations, thus allowing more opportunity for mitigation. Note that for both BWRs and PWRs the frequency of reactor protection system failure remains highly uncertain. Therefore, all comparisons concerning ATWS should be made with caution.

Station blackout accidents contribute a high percentage of the core damage frequency for the BWRs. However, when viewed on an absolute scale, station blackout has a higher frequency at the PWRs than at the BWRs. To some extent this is due to design differences between BWRs and PWRs leading to different susceptibilities. For example, in station blackout accidents, PWRs are potentially vulnerable to reactor coolant pump seal LOCAs following loss of seal cooling, leading to loss of inventory with no method for providing makeup. BWRs, on the other hand, have at least one injection system that does not require ac power. While important, it would be incorrect to imply that the differences noted above are the only considerations that drive the variations in the core damage frequency. Probably more important is the electric power system design at each plant, which is largely independent of the plant type. The station blackout frequency is low at Peach Bottom because of the presence of four diesels that can be shared between units and a maintenance program that led to an order of magnitude reduction in the diesel generator failure rates. Grand Gulf has essentially three trains of emergency ac power for one unit, with one of the trains being both diverse and independent from the other two. These characteristics of the electric power system design tend to dominate any differences in the reactor design. Therefore, a BWR with a below average electric power system reliability could be expected to have a higher station blackout-induced core damage frequency than a PWR with an above average electric power system.

For both BWRs and PWRs, the analyses indicate that, along with electric power, other support systems, such as service water, are quite important. Because these systems vary considerably among plants, caution must be exercised when making statements about generic classes of plants, such as PWRs versus BWRs. Once significant plant-specific vulnerabilities are removed, support-system-driven sequences will probably dominate the core damage frequency of both types of plants. Both types of plants have sufficient redundancy and diversity so as to make multiple independent failures unlikely. Support system failures introduce dependencies among the systems and thus can become dominant.

Boiling Water Reactor Observations

As shown in Figure 8.1, the internal-event core damage frequencies for Peach Bottom and Grand Gulf are extremely low. Therefore, even though dominant plant damage states and contributing

failure events can be identified, these items should not be considered as safety problems for the two plants. In fact, these dominating factors should not be overemphasized because, for core damage frequencies below $1E-5$, it is possible that other events outside the scope of these internal-event analyses are the ones that actually dominate. In the cases of these two plants, the real perspectives come not from understanding why particular sequences dominate, but rather why all types of sequences considered in the study have low frequencies for these plants.

Previously it was noted that LOCA sequences can be expected to have low frequencies at BWRs because of the numerous systems available to provide coolant injection. While low for both plants, the frequency of LOCAs is higher for Peach Bottom than for Grand Gulf. This is primarily because Grand Gulf is a BWR-6 design with a motor-driven high-pressure core spray system, rather than a steam-driven high-pressure coolant injection system as is Peach Bottom. Motor-driven systems are typically more reliable than steam-driven systems and, more importantly, can operate over the entire range of pressures experienced in a LOCA sequence.

It is evident from Figures 8.2 and 8.4 that station blackout plays a major role in the internal-event core damage frequencies for Peach Bottom and Grand Gulf. Each of these plants has features that tend to reduce the station blackout frequency, some of which would not be present at other BWRs.

Grand Gulf, like all BWR-6 plants, is equipped with an extra diesel generator dedicated to the high-pressure core spray system. While effectively providing a third train of redundant emergency ac power for decay heat removal, the extra diesel also provides diversity, based on a different diesel design and plant location relative to the other two diesels. Because of the aspect of diversity, the analysis neglected common-cause failures affecting all three diesel generators. The net effect is a highly reliable emergency ac power capability. In those unlikely cases where all three diesel generators fail, Grand Gulf relies on a steam-driven coolant injection system that can function until the station batteries are depleted. At Grand Gulf the batteries are sized to last for many hours prior to depletion so that there is a high probability of recovering ac power prior to core damage. In addition, there is a diesel-driven firewater system available that can be used to provide coolant injection in some sequences involving the loss of ac power.

Peach Bottom is an older model BWR that does not have a diverse diesel generator for the high-pressure core spray system. However, other factors contribute to a low station blackout frequency at Peach Bottom. Peach Bottom is a two-unit site, with four diesel generators available. Any one of the four diesels can provide sufficient capacity to power both units in the event of a loss of offsite power, given that appropriate crossties or load swapping between Units 2 and 3 are used. This high level of redundancy is somewhat offset by a less redundant service water system that provides cooling to the diesel generators. Subtleties in the design are such that if a certain combination of diesel generators fails, the service water system will fail, causing the other diesels to fail. In addition, station dc power is needed to start the diesels. (Some emergency diesel generator systems, such as those at Surry, have a separate dedicated dc power system just for starting purposes.) In spite of these factors, the redundancy in the Peach Bottom emergency ac power system is considerable.

While there is redundancy in the ac power system design at Peach Bottom, the most significant factor in the low estimated station blackout frequency relates to the plant-specific data analysis. The plant-specific analysis determined that, because of a high-quality maintenance program, the diesel generators at Peach Bottom had approximately an order of magnitude greater reliability than at an average plant. This factor directly influences the frequency.

Finally, Peach Bottom, like Grand Gulf, has station batteries that are sized to last several hours in the event that the diesel generators do fail. With two steam-driven systems to provide coolant injection and several hours to recover ac power prior to battery depletion, the station blackout frequency is further reduced.

Unlike most PWRs, the response of containment is often a key in determining the core damage frequency for BWRs. For example, at Peach Bottom, there are a number of ways in which containment conditions can affect coolant injection systems. High pressure in containment can lead to closure of primary system relief valves, thus failing low-pressure injection systems, and can also lead to failure of steam-driven high-pressure injection systems due to high turbine exhaust backpressure. High suppression pool temperatures can also lead to the failure of systems that are recirculating water from the suppression pool to the reactor coolant system. If the containment ultimately fails, certain systems can fail because of the loss of net

8. Core Damage Frequency

positive suction head in the suppression pool, and also the reactor building is subjected to a harsh steam environment that can lead to failure of equipment located there.

Despite the concerns described in the previous paragraph, the core damage frequency for Peach Bottom is relatively low, compared to the PWRs. There are two major reasons for this. First, Peach Bottom has the ability to vent the wetwell through a 6-inch diameter steel pipe, thus reducing the containment pressure without subjecting the reactor building to steam. While this vent cannot be used to mitigate ATWS and station blackout sequences, it is valuable in reducing the frequency of many other sequences. The second important feature at Peach Bottom is the presence of the control rod drive system, which is not affected by either high pressure in containment or containment failure. Other plants of the BWR-4 design may be more susceptible to containment-related problems if they do not have similar features. For example, some plants have ducting, as opposed to hard piping available for venting. Venting through ductwork may lead to harsh steam environments and equipment failures in the reactor building.*

The Grand Gulf design is generally much less susceptible to containment-related problems than Peach Bottom. The containment design and equipment locations are such that containment rupture will not result in discharge of steam into the building containing the safety systems. Further, the high-pressure core spray system is designed to function with a saturated suppression pool so that it is not affected by containment failure. Finally, there are other systems that can provide coolant injection using water sources other than the suppression pool. Thus, containment failure is relatively benign as far as system operation is concerned, and there is no obvious need for containment venting.

Pressurized Water Reactor Observations

The three PWRs examined in this study reflect much more variety in terms of dominant plant damage states than the BWRs. While the sequence frequencies are generally low for most of the plant damage states, it is useful to understand why the variations among the plants occurred.

For LOCA sequences, the frequency is significantly lower at Surry than at the other two PWRs. A major portion of this difference is directly tied

*The staff is presently undertaking regulatory action to require hard pipe vents in all BWR Mark I plants.

to the additional redundancy available in the injection systems. In addition to the normal high-pressure injection capability, Surry can cross tie to the other unit at the site for an additional source of high-pressure injection. This reduces the core damage frequency due to LOCAs and also certain groups of transients involving stuck-open relief valves.

In addition, at Sequoyah there is a particularly noteworthy emergency core cooling interaction with containment engineered safety features in loss-of-coolant accidents. In this (ice condenser) containment design, the containment sprays are automatically actuated at a very low pressure set-point, which would be exceeded for virtually all small LOCA events. This spray actuation, if not terminated by the operator can lead to a rapid depletion of the refueling water storage tank at Sequoyah. Thus, an early need to switch to recirculation cooling may occur. Portions of this switchover process are manual at Sequoyah and, because of the timing and possible stressful conditions, leads to a significant human error probability. Thus, LOCA-type sequences are the dominant accident sequence type at Sequoyah.

Station blackout-type sequences have relatively similar frequencies at all three PWRs. Station blackout sequences can have very different characteristics at PWRs than at BWRs. One of the most important findings of the study is the importance of reactor coolant pump seal failures. During station blackout, all cooling to the seals is lost and there is a significant probability that they will ultimately fail, leading to an induced LOCA and loss of inventory. Because PWRs do not have systems capable of providing coolant makeup without ac power, core damage will result if power is not restored. The seal LOCA reduces the time available to restore power and thus increases the station blackout-induced core damage frequency. New seals have been proposed for Westinghouse PWRs and could reduce the core damage frequency if implemented, although they might also increase the likelihood that any resulting accidents would occur at high pressure, which has implications for the accident progression analysis. (See Section C.14 of Appendix C for a more detailed discussion of reactor coolant seal performance.)

Apart from the generic reactor coolant pump seal question, station blackout frequencies at PWRs are determined by the plant-specific electric power system design and the design of other support systems. Battery depletion times for the three PWRs were projected to be shorter than for the two BWRs. A particular characteristic of the

Surry plant is a gravity-fed service water system with a canal that may drain during station blackout, thus failing containment heat removal. When power is restored, the canal must be refilled before containment heat removal can be restored.

The dominant accident sequence type at Zion is not a station blackout, but it has many similar characteristics. Component cooling water is needed for operation of the charging pumps and high-pressure safety injection pumps at Zion. Loss of component cooling water (or loss of service water, which will also render component cooling water inoperable) will result in loss of these high-pressure systems. This in turn leads to a loss of reactor coolant pump seal injection. Simultaneously, loss of component cooling water will also result in loss of cooling to the thermal barrier heat exchangers for the reactor coolant pump seals. Thus, the reactor coolant pump seals will lose both forms of cooling. As with station blackout, loss of component cooling water or service water can both cause a small LOCA (by seal failure) and disable the systems needed to mitigate it. The importance of this scenario is increased further by the fact that the component cooling water system at Zion, although it uses redundant pumps and valves, delivers its flow through a common header. The licensee for the Zion plant has made procedural changes and is also considering both the use of new seal materials and the installation of modifications to the cooling water systems. These measures, which are discussed in more detail in Chapter 7, reduce the importance of this contributor.

ATWS frequencies are generally low at all three of the PWRs. This is due to the assessed reliability of the shutdown systems and the likelihood that only slow-acting, low-power-level events will result.

While of low frequency, it is worth noting that interfacing-system LOCA (V) and steam generator tube rupture (SGTR) events do contribute significantly to risk for the PWRs. This is because they involve a direct path for fission products to bypass containment. There are large uncertainties in the analyses of these two accident types, but these events can be important to risk even at frequencies that may be one or two orders of magnitude lower than other sequence types.

During the past few years, most Westinghouse PWRs have developed procedures for using feed and bleed cooling and secondary system blowdown to cope with loss of all feedwater. These procedures have led to substantial reductions in the frequencies of transient sequences involving

the loss of main and auxiliary feedwater. Appropriate credit for these actions was given in these analyses. However, there are plant-specific features that will affect the success rate of such actions. For example, the loss of certain power sources (possibly only one bus) or other support systems can fail power-operated relief valves (PORVs) or atmospheric dump valves or their block valves at some plants, precluding the use of feed and bleed or secondary system blowdown. Plants with PORVs that tend to leak may operate for significant periods of time with the block valves closed, thus making feed and bleed less reliable. On the other hand, if certain power failures are such that open block valves cannot be closed, then they cannot be used to mitigate stuck-open PORVs. Thus, both the system design and plant operating practices can be important to the reliability assessment of actions such as feed and bleed cooling.

8.4.4 External Events

The frequency of core damage initiated by external events has been analyzed for two of the plants in this study, Surry and Peach Bottom (Ref. 8.1 (Part 3) and Ref. 8.2 (Part 3)). The analysis examined a broad range of external events, e.g., lightning, aircraft impact, tornados, and volcanic activity (Ref. 8.8). Most of these events were assessed to be insignificant contributors by means of bounding analyses. However, seismic events and fires were found to be potentially major contributors and thus were analyzed in detail.

Figures 8.7 and 8.8 show the results of the core damage frequency analysis for seismic- and fire-initiated accidents, as well as internally initiated accidents, for Surry and Peach Bottom, respectively. Examination of these figures shows that the core damage frequency distributions of the external events are comparable to those of the internal events. It is evident that the external events are significant in the total safety profile of these plants.

Seismic Analysis Observations

The analysis of the seismically induced core damage frequency begins with the estimation of the seismic hazard, that is, the likelihood of exceeding different earthquake ground-motion levels at the plant site. This is a difficult, highly judgmental issue, with little data to provide verification of the various proposed geologic and seismologic models.

The sciences of geology and seismology have not yet produced a model or group of models upon which all experts agree. This study did not itself

8. Core Damage Frequency

produce seismic hazard curves, but instead made use of seismic hazard curves for Peach Bottom and Surry that were part of an NRC-funded Lawrence Livermore National Laboratory project that resulted in seismic hazard curves for all nuclear power plant sites east of the Rocky Mountains (Ref. 8.9).

In addition, the Electric Power Research Institute (EPRI) developed a separate set of models (Ref. 8.10). For purposes of completeness and comparison, the seismically induced core damage frequencies were also calculated based upon the EPRI methods. Both sets of results, which are presented in Figures 8.5 through 8.8, were used in this study. More detailed discussion of methods used in the seismic analysis is provided in Appendix A; Section C.11 of Appendix C provides more detailed perspectives on the seismic issue as well.

As can be seen in Figures 8.5 and 8.6, the shapes of the seismically induced core damage probability distributions are considerably different from those of the internally initiated and fire-initiated events. In particular, the 5th to 95th percentile range is much larger for the seismic events. In addition, as can be seen in Figures 8.7 and 8.8, the wide disparity between the mean and the median and the location of the mean relatively high in the distribution indicate a wide distribution with a tail at the high end but peaked much lower down. (This is a result of the uncertainty in the seismic hazard curve.)

It can be clearly seen that the difference between the mean and median is an important distinction. The mean is the parameter quoted most often, but the bulk of the distribution is well below the mean. Thus, although the mean is the "center of gravity" of the distribution (when viewed on a linear rather than logarithmic scale), it is not very representative of the distribution as a whole. Instead, it is the lower values that are more probable. The higher values are estimated to have low probability, but, because of their great distance from the bulk of the distribution, the mean is "pulled up" to a relatively high value. In a case such as this, it is particularly evident that the entire distribution, not just a single parameter such as the mean or the median, must be considered when discussing the results of the analysis.

1. Surry Seismic Analysis

The core damage frequency probability distributions, as calculated using the Livermore and EPRI methods, have a large degree of overlap, and the differences between the means and medians of

the two resulting distributions are not very meaningful because of the large widths of the two distributions.

The breakdown of the Surry seismic analysis into principal contributors is reasonably similar to the results of other seismic PRAs for other PWRs. The total core damage frequency is dominated by loss of offsite power transients resulting from seismically induced failures of the ceramic insulators in the switchyard. This dominant contribution of ceramic insulator failures has been found in virtually all seismic PRAs to date.

A site-specific but significant contributor to the core damage frequency at Surry is failure of the anchorage welds of the 4 kV buses. These buses play a vital role in providing emergency ac electrical power since offsite power as well as emergency onsite power passes through these buses. Although these welded anchorages have more than adequate capacity at the safe shutdown earthquake (SSE) level, they do not have sufficient margin to withstand (with high reliability) earthquakes in the range of four times the SSE, which are contributing to the overall seismic core damage frequency results.

Similarly, a substantial contribution is associated with failures of the diesel generators and associated load center anchorage failures. These anchorages also may not have sufficient capacity to withstand earthquakes at levels of four times the SSE.

Another area of generic interest is the contribution due to vertical flat-bottomed storage tanks, e.g., refueling water storage tanks and condensate storage tanks. Because of the nature of their configuration and field erection practices, such tanks have often been calculated to have relatively smaller margin over the SSE than most components in commercial nuclear power plants. Given that all PWRs in the United States use the refueling water storage tank as the primary source of emergency injection water (and usually the sole source until the recirculation phase of ECCS begins), failure of the refueling water storage tank can be expected to be a substantial contributor to the seismically induced core damage frequency.

2. Peach Bottom Seismic Analysis

As can be seen in Figure 8.9, the dominant contributor in the seismic core damage frequency analysis is a transient sequence brought about by loss of offsite power. The loss of offsite power is due to seismically induced failures of onsite ac power. Peach Bottom has four emergency diesel

generators, all shared between the two units, and four station batteries per unit. Thus, there is a high degree of redundancy. However, all diesels require cooling provided by the emergency service water system, and failure to provide this cooling will result in failure of all four diesels.

There is a variety of seismically induced equipment failures that can fail the emergency service water system and result in a station blackout. These include failure of the emergency cooling tower, failures of the 4 kV buses (in the same manner as was found at Surry), and failures of the emergency service water pumps or the emergency diesel generators themselves. The various combinations of these failures result in a large number of potential failure modes and give rise to a relatively high frequency of core damage based on station blackout. None of these equipment failure probabilities is substantially greater than would be implied by the generic fragility data available. However, the high probability of exceedance of larger earthquakes (as prescribed by the hazard curves for this site) results in significant contributions of these components to the seismic risk.

Fire Analysis Observations

The core damage likelihood due to a fire in any particular area of the plant depends upon the frequency of ignition of a fire in the area, the amount and nature of combustible material in that area, the nature and efficacy of the fire-suppression systems in that area, and the importance of the equipment located in that area, as expressed in the potential of the loss of that equipment to cause a core damage accident sequence. The methods used in the fire analysis are described in Appendix A and in Reference 8.7; Section C.12 of Appendix C provides additional perspectives on the fire analysis.

1. Surry Fire Analysis

Figure 8.10 shows the dominant contributors to core damage frequency resulting from the Surry fire analysis. The dominant contributor is a transient resulting in a reactor coolant pump seal LOCA, which can lead to core damage. The scenario consists of a fire in the emergency switchgear room that damages power or control cables for the high-pressure injection and component cooling water pumps. No additional random failures are required for this scenario to lead to core damage. It should be noted that credit was given for existing fire-suppression systems and for recovery by crossconnecting high-pressure injection from the other unit. The importance of this

scenario is evident in Figure 8.11, which breaks down the fire-induced core damage frequency by location in the plant. The most significant physical location is the emergency switchgear room. In this room, cable trays for the two redundant power trains were run one on top of the other with approximately 8 inches of vertical separation in a number of plant areas, which gives rise to the common vulnerability of these two systems due to fire. In addition, the Halon fire-suppression system in this room is manually actuated.

The other principal contributor is a spuriously actuated pressurizer PORV. In this scenario, fire-related component damage in the control room includes control power for a number of safety systems. Full credit was given for independence of the remote shutdown panel from the control room except in the case of PORV block valves; discussions with utility personnel indicated that control power for these valves was not independently routed.

2. Peach Bottom Fire Analysis

Figure 8.10 shows the mechanisms by which fire leads to core damage in the Peach Bottom analysis. Station blackout accidents are the dominant contributor, with substantial contributions also coming from fire-induced transients and losses of offsite power. The relative importance of the various physical locations is shown in Figure 8.12.

It is evident from Figure 8.12 that control room fires are of considerable significance in the fire analysis of this plant. Fires in the control room were divided into two scenarios, one for fires initiating in the reactor core isolation cooling (RCIC) system cabinet and one for all others. Credit was given for automatic cycling of the RCIC system unless the fire initiated within its control panel. Because of the cabinet configuration within the control room, the fire was assumed not to spread and damage any components outside the cabinet where the fire initiated. The analysis gave credit for the possibility of quick extinguishing of the fire within the applicable cabinet since the control room is continuously occupied. However, should these efforts fail, even with high ventilation rates, these scenarios postulate forced abandonment of the control room due to smoke from the fire and subsequent plant control from the remote shutdown panel.

The cable spreading room below the control room is significant but not dominant in the fire analysis. The scenario of interest is a fire-induced transient coupled with fire-related failures of the control power for the high-pressure coolant injection

8. Core Damage Frequency

system, the reactor core isolation cooling system, the automatic depressurization system, and the control rod drive hydraulic system. The analysis gave credit to the automatic CO₂ fire-suppression system in this area.

The remaining physical areas of significance are the emergency switchgear rooms. The fire-induced core damage frequency is dominated by fire damage to the emergency service water system in conjunction with random failures coupled with fire-induced loss of offsite power. In all eight emergency switchgear rooms (four shared between the two units), both trains of offsite power are routed. It was noted that in each of these areas there are breaker cubicles for the 4 kV switchgear with a penetration at the top that has many small cables routed through it. These penetrations were inadequately sealed, which would allow a fire to spread to cabling that was directly above the switchgear room. This cabling was a sufficient fuel source for the fire to cause a rapid formation of a hot gas layer that would then lead to a loss of offsite power. Since both offsite power and the emergency service water systems are lost, a station blackout would occur.

Perspectives: General Observations on Fire Analysis

Figures 8.7 and 8.8 clearly indicate that

fire-initiated core damage sequences are significant in the total probabilistic analysis of the two plants analyzed. Moreover, these analyses already include credit for the fire protection programs required by Appendix R to 10 CFR Part 50.

Although the two plants are of completely different design, with completely different fire-initiated core damage scenarios, the possibility of fires in the emergency switchgear areas is important in both plants. The importance of the emergency switchgear room at Surry is particularly high because of the seal LOCA scenario. Further, the importance of the control room at Surry is comparable to that of the control room at Peach Bottom.

This is not surprising in view of the potential for simultaneous failure of several systems by fires in these areas. Thus, in the past such areas have generally received particular attention in fire protection programs. It should also be noted that the significance of various areas also depends upon the scenario that leads to core damage. For example, the importance of the emergency switchgear room at Surry could be altered (if desired) not only by more fire protection programs but also by changes in the probability of the reactor coolant pump seal failure.

REFERENCES FOR CHAPTER 8

- 8.1 R. C. Bertucio and J. A. Julius, "Analysis of Core Damage Frequency: Surry Unit 1," Sandia National Laboratories, NUREG/CR-4550, Vol. 3, Revision 1, SAND86-2084, April 1990.
- 8.2 A. M. Kolaczowski et al., "Analysis of Core Damage Frequency: Peach Bottom Unit 2," Sandia National Laboratories, NUREG/CR-4550, Vol. 4, Revision 1, SAND86-2084, August 1989.
- 8.3 R. C. Bertucio and S. R. Brown, "Analysis of Core Damage Frequency: Sequoyah Unit 1," Sandia National Laboratories, NUREG/CR-4550, Vol. 5, Revision 1, SAND86-2084, April 1990.
- 8.4 M. T. Drouin et al., "Analysis of Core Damage Frequency: Grand Gulf Unit 1," Sandia National Laboratories, NUREG/CR-4550, Vol. 6, Revision 1, SAND86-2084, September 1989.
- 8.5 M. B. Sattison and K. W. Hall, "Analysis of Core Damage Frequency: Zion Unit 1," Idaho National Engineering Laboratory, NUREG/CR-4550, Vol. 7, Revision 1, EGG-2554, May 1990.
- 8.6 USNRC, "Reactor Safety Study—An Assessment of Accident Risks in U. S. Commercial Nuclear Power Plants," WASH-1400 (NUREG-75/014), October 1975.
- 8.7 H. J. C. Kouts et al., "Special Committee Review of the Nuclear Regulatory Commission's Severe Accident Risks Report (NUREG-1150)," NUREG-1420, August 1990.
- 8.8 M. P. Bohn and J. A. Lambright, "Procedures for the External Event Core Damage Frequency Analyses for NUREG-1150," Sandia National Laboratories, NUREG/CR-4840, SAND88-3102, November 1990.
- 8.9 D. L. Bernreuter et al., "Seismic Hazard Characterization of 69 Nuclear Power Sites East of the Rocky Mountains," Lawrence Livermore National Laboratory, NUREG/CR-5250, Vols. 1-8, UCID-21517, January 1989.
- 8.10 Seismicity Owners Group and Electric Power Research Institute, "Seismic Hazard Methodology for the Central and Eastern United States," Electric Power Research Institute, EPRI NP-4726, July 1986.

9. PERSPECTIVES ON ACCIDENT PROGRESSION AND CONTAINMENT PERFORMANCE

9.1 Introduction

The consequences of severe reactor accidents depend greatly on containment safety features and containment performance in retaining radioactive material. The early failure of the containment structures at the Chernobyl power plant contributed to the size of the environmental release of radioactive material in that accident. In contrast, the radiological consequences of the Three Mile Island Unit 2 (TMI-2) accident were minor because overall containment integrity was maintained and bypass was small. Normally three barriers (the fuel rod cladding, the reactor coolant system pressure boundary, and the containment pressure boundary) protect the public from the release of radioactive material generated in nuclear fuel. In most core meltdown scenarios, the first two barriers would be progressively breached, and the containment boundary represents the final barrier to release of radioactivity to the environment. Maintaining the integrity of the containment can affect the source term by orders of magnitude. The NRC's 1986 reassessment of source term issues reaffirmed that containment performance "is a major factor affecting source terms" (Ref. 9.1).

In most severe accident sequences, the ability of a containment boundary to maintain integrity is determined by two factors: (1) the magnitude of the loads, and (2) the response to those loads of the containment structure and the penetrations through the containment boundary. Although there is no universally accepted definition of containment failure, it does not necessarily imply gross structural failure. For risk purposes, containment is considered to have failed to perform its function when the leak rate of radionuclides to the environment is substantial. Thus, failure could occur as the result of a structural failure of the containment, tearing of the containment liner, or a high rate of a leakage through a penetration. Finally, valves that are open during normal operation may not close properly when the accident occurs. Failure of the containment isolation system can result in leakage of radioactive material to a secondary building or directly to the environment.

In some accidents, the containment building is completely bypassed. In interfacing-system loss-of-coolant accidents (LOCAs), check valves isolating low-pressure piping fail, and the piping con-

nected to the reactor coolant system fails outside the containment. The radionuclides can escape to secondary buildings through the reactor coolant system piping without passing through the containment. A similar bypass can occur in a core meltdown sequence initiated by the rupture of a steam generator tube in which release is through relief valves on the steam line from the failed steam generators.

Although the five plants analyzed in the present study were selected to span the basic types of containment design used in the United States, it cannot be assumed that the containment performance results obtained are characteristic of a class of plants. The loads in an accident sequence, the relative frequencies of specific accident sequences, and the load level at which the containment fails can all be influenced by design details that vary among reactors within a class of containments. (Additional discussion of the extrapolability of PRA results is provided in Chapter 13.)

9.2 Summary of Results

If the containment function is maintained in a severe accident, the radiological consequences will be minor. If the containment function does fail, the timing of failure can be very important. The longer the containment remains intact relative to the time of core melting and radionuclide release from the reactor coolant system, the more time is available to remove radioactive material from the containment atmosphere by engineered safety features or natural deposition processes. Delay in containment failure or containment bypass also provides time for protective action, a very important consideration in the assessment of possible early health effects. Thus, in evaluating the performance of a containment, it is convenient to consider no failure, late failure, bypass, and early failure of containment as separate categories characterizing different degrees of severity. For those plants in which intentional venting is an option, this is also represented as a separate category.

Not all accident sequences that involve core damage would necessarily progress to vessel failure, as illustrated by the TMI-2 accident. The operator may recover a critical system (such as by the return of offsite power) or the state of the plant may change (for example, the system pressure may fall to a point where low-pressure emergency coolant

9. Accident Progression

systems can be activated) allowing the core to be recovered and the accident to be terminated. The likelihood of containment failure in terminated accidents is typically less than in accidents involving vessel failure, and the radiological consequences are usually very small.

9.2.1 Internal Events

The probability of early containment failure and vessel breach conditional on the indicated class of sequence (and the mean frequency of the class) is illustrated in Figure 9.1 for three classes of accident sequences in the pressurized water reactors (PWRs) analyzed in this study and in Figure 9.2 for three classes of accident sequences in the boiling water reactors (BWRs) analyzed (Refs. 9.2 through 9.6). Containment bypass scenarios are not included in these figures, and the results are for internally initiated accidents. For different plant designs, the nature of the loads and the response of the containment are different, even for the same accident class.

The predicted likelihoods of early containment failure in the Zion (large, dry design) plant and the Surry (subatmospheric design) plant are quite small (mean value of about 1 percent). The principal mechanisms leading to these failures are loads resulting from high-pressure melt ejection in accident sequences with high reactor coolant system (RCS) pressures (at time of vessel breach) and in-vessel steam explosions in sequences with low RCS pressures at vessel breach. Both phenomena involve substantial uncertainties.

The principal reason that the probability of early containment failure from loads at vessel breach is so small in the Surry and Zion analyses is that the reactor coolant system is not likely to be at high pressure when vessel meltthrough occurs. Some of the mechanisms that were found to be effective in depressurizing the vessel are hot leg or surge line failure at elevated temperature, failure of a reactor coolant pump seal, or a stuck-open relief valve. If an extreme case at Surry is selected, which is a large core fraction ejected, a dry cavity, no sprays, a large hole in the vessel, and high reactor coolant system pressure, the conditional probability of containment failure is approximately 30 percent. However, this is a very unlikely case. For cases with small holes in the reactor vessel and a small or intermediate fraction of the core ejected, which are much more likely, the probability of containment failure is a few percent or less.

For accident sequences at Surry and Zion in which core uncover is initiated with the reactor

coolant system at high pressure, the probability of overheating and rupturing steam generator tubes after the onset of core damage, with subsequent bypass of the containment, is of the same magnitude as the probability of early containment failure from high-pressure ejection of core debris with direct containment heating. In Figure 9.1, the smaller spread in uncertainty in the downward direction for the Zion plant is due to the higher frequency of containment isolation failure, which establishes a lower bound for the distribution.

The results for the Sequoyah plant indicate that early containment failure is somewhat more likely for ice condenser designs than for large, high-pressure containments. The mean likelihood of early failure is approximately 12 percent (8 percent includes vessel breach, 4 percent does not). Early containment failure is primarily the result of loads at vessel failure. For scenarios in which the vessel is at high pressure at the time of vessel breach, early failure results from overpressurization (including the pressure load from hydrogen burning) or from direct attack of the containment by hot debris following failure of the seal table. If the vessel is at low pressure at vessel breach, the principal failure mechanism is overpressurization.

The predicted probability of early failure of the Peach Bottom and Grand Gulf pressure-suppression containments is substantially higher than for the PWR containment designs. For Grand Gulf, the mean probability of early failure is approximately 50 percent while at Peach Bottom the mean probability of early failure is about 56 percent.

In the Peach Bottom (Mark I design) plant, failure is predicted to occur primarily in the drywell as a result of direct attack by molten core debris. Drywell rupture due to pedestal failure or rapid overpressurization (more quickly than the water columns in the vent lines can be cleared) is also an important contributor to early containment failure. If failure occurs in the drywell, releases of radionuclides from fuel after vessel failure will not pass through the suppression pool. Late failure of containment is also most likely to occur in the drywell but in the form of prolonged leakage past the drywell head.

At Grand Gulf, early containment failure in station blackout is dominated by hydrogen deflagrations. Hydrogen detonations are also small contributors to early failure. For short-term station blackouts (the dominant plant damage state groups), the conditional probability of early

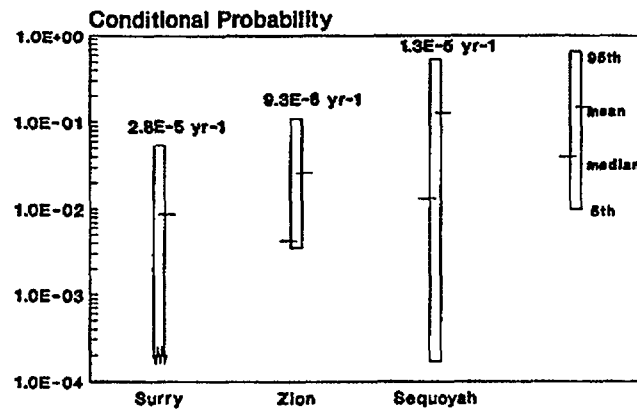

a. Station blackout

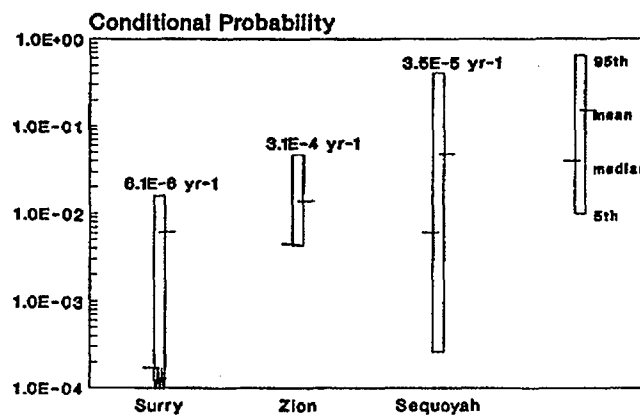

b. Loss-of-coolant accidents

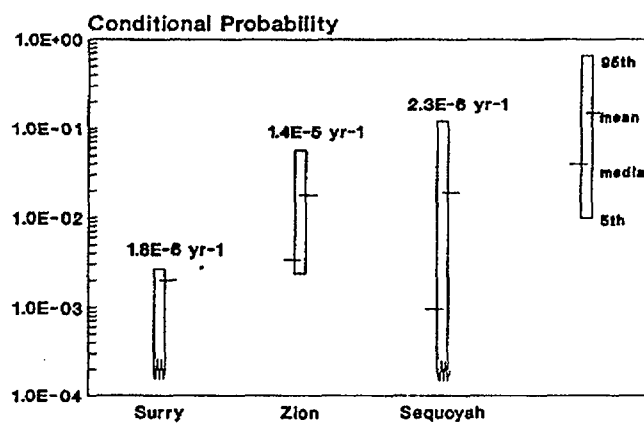

c. Transients

Figure 9.1 Conditional probability of early containment failure for key plant damage states (PWRs).

9. Accident Progression

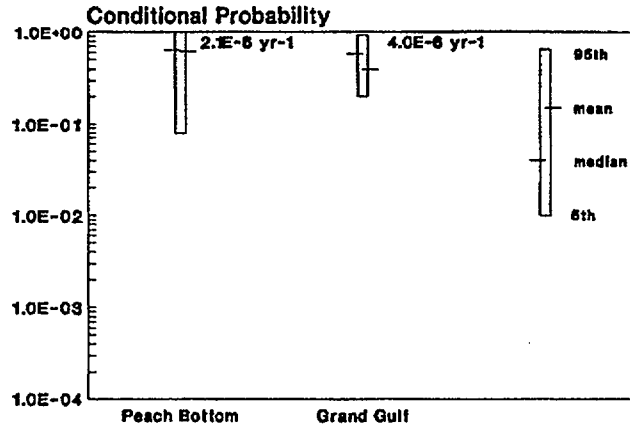

a. Station blackout

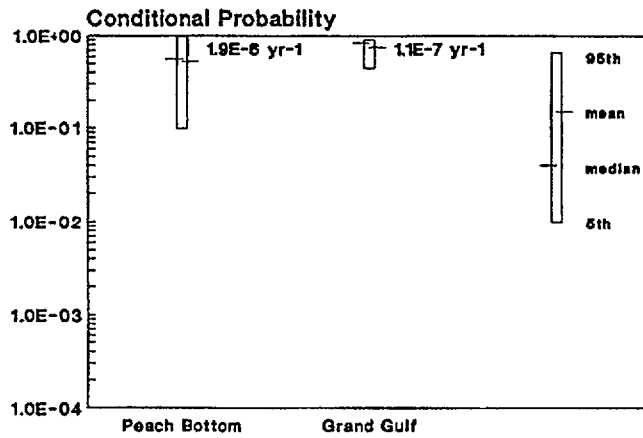

b. Anticipated transients without scram

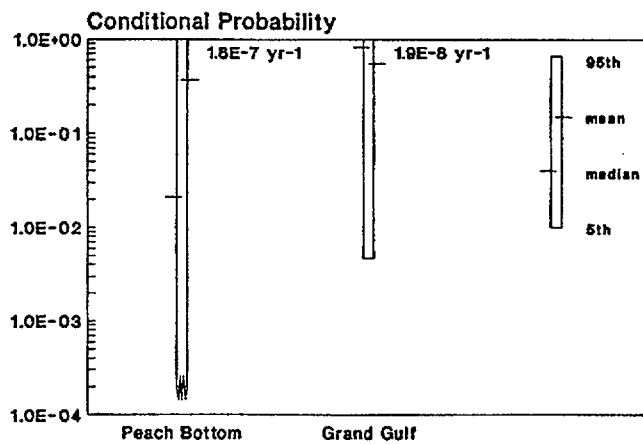

c. Transients

Figure 9.2 Conditional probability of early containment failure for key plant damage states (BWRs).

containment failure is 50 percent. About half of the early containment failures occur before vessel breach, and the other half occur at or shortly after vessel breach. For the long-term station blackouts, the mean conditional probability of early containment failure is 85 percent.

The probability of drywell failure at Grand Gulf is somewhat less than that of containment failure and occurs in approximately one-half the early containment failures. Drywell failures before vessel breach result from rapid hydrogen deflagrations in the wetwell. At the time of vessel breach, however, drywell failures are primarily from drywell pressurization loads at vessel breach (steam blowdown, direct containment heating, ex-vessel steam explosions, and hydrogen combustion). Failure of the drywell is more likely when vessel breach occurs with the vessel at high pressure.

Intentional venting of the containment was considered to prevent overpressurization failure of the containment for both Peach Bottom and Grand Gulf. The mean probability of sequences in which containment venting occurs and no containment failure occurs is approximately 10 percent for Peach Bottom station blackout sequences and 4 percent for Grand Gulf. The values are small, mostly because of the high probability of early failure mechanisms for which venting is ineffective. Furthermore, for the short-term station blackout plant damage state that dominates the core melt frequency at Grand Gulf, ac power is not available initially to permit venting.

Figure 9.3 illustrates the frequency of early failure or bypass of containment (the two types of failure with the potential for a large release of radionuclides) for internally initiated accidents in each of the five plants. (Peach Bottom scenarios in which the containment has been vented but subsequent early containment failure has occurred are categorized as early containment failures.) Note that, on a basis of absolute frequency, early containment failure or bypass for the BWR designs analyzed is similar to that of the PWRs because of the lower predicted frequency of core damage in the BWRs.

The relative probabilities of early containment failure, bypass, late failure, venting, and no containment failure are illustrated in Figure 9.4 for each of the plants. For the Surry plant, the likelihood of bypass, an interfacing-system LOCA, or steam generator tube rupture is somewhat greater than that of early failure from severe accident loads. In Figure 9.4, the capability of the Zion

plant to avoid a large early release of radioactive material appears to be particularly good because of the small fraction of failures that result in either early failure or bypass.

It should be noted that the averaging of containment failure mode probabilities for different plant damage states can be misleading. To a large degree, the relative probability of bypass at Zion is substantially smaller than at Surry because the frequency of plant damage states, other than the interfacing-system LOCA, is higher. On an absolute frequency scale, as shown in Figure 9.3, the performances of the Surry and Zion containments in severe accidents are quite similar. In Sequoyah, the probability of early failure is somewhat larger than for the other PWRs analyzed and on a frequency-weighted mean basis is essentially the same as for bypass. The most likely outcome for these plants is that the containment will not fail.

Using early containment failure or containment bypass as a measure for comparison, the performance of the two BWR containments analyzed does not appear as good as the performance of the PWR containments. It is important to recognize that early containment failure or bypass is a prerequisite for a large release of radionuclides, but that mitigative features within the plant can substantially limit the release that occurs. This is particularly true for the pressure-suppression containment designs, where the suppression pool or ice condenser can retain radionuclides even if the containment has failed. (The BWR frequency of bypass is assessed to be quite small. Therefore, only early failures (with the potential for some radionuclide scrubbing by the suppression pool) are important.) The frequency of release of different quantities of radionuclides is discussed in Chapter 10.

9.2.2 External Events

Plant damage states that result from external events are quite similar to those that arise from internally initiated accidents except that their relative frequencies differ substantially. In addition, containment status may be affected by the initiating event. Figure 9.5 illustrates the relative probabilities of early containment failure, bypass, late failure, venting, and no failure (no vessel breach or vessel breach with no containment failure) for the two plants for which external-event analyses were performed. The results for internal initiators, fire, and seismic are compared in the figure. The importance of early containment failure relative to the importance of bypass is reversed in the Surry

9. Accident Progression

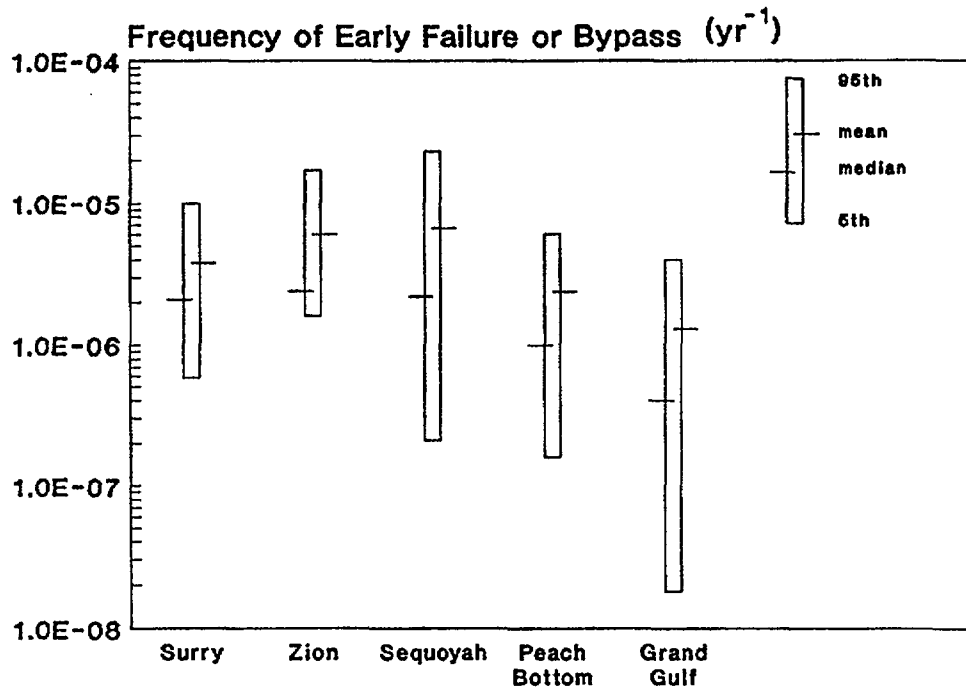

Figure 9.3 Frequency of early containment failure or bypass (all plants).

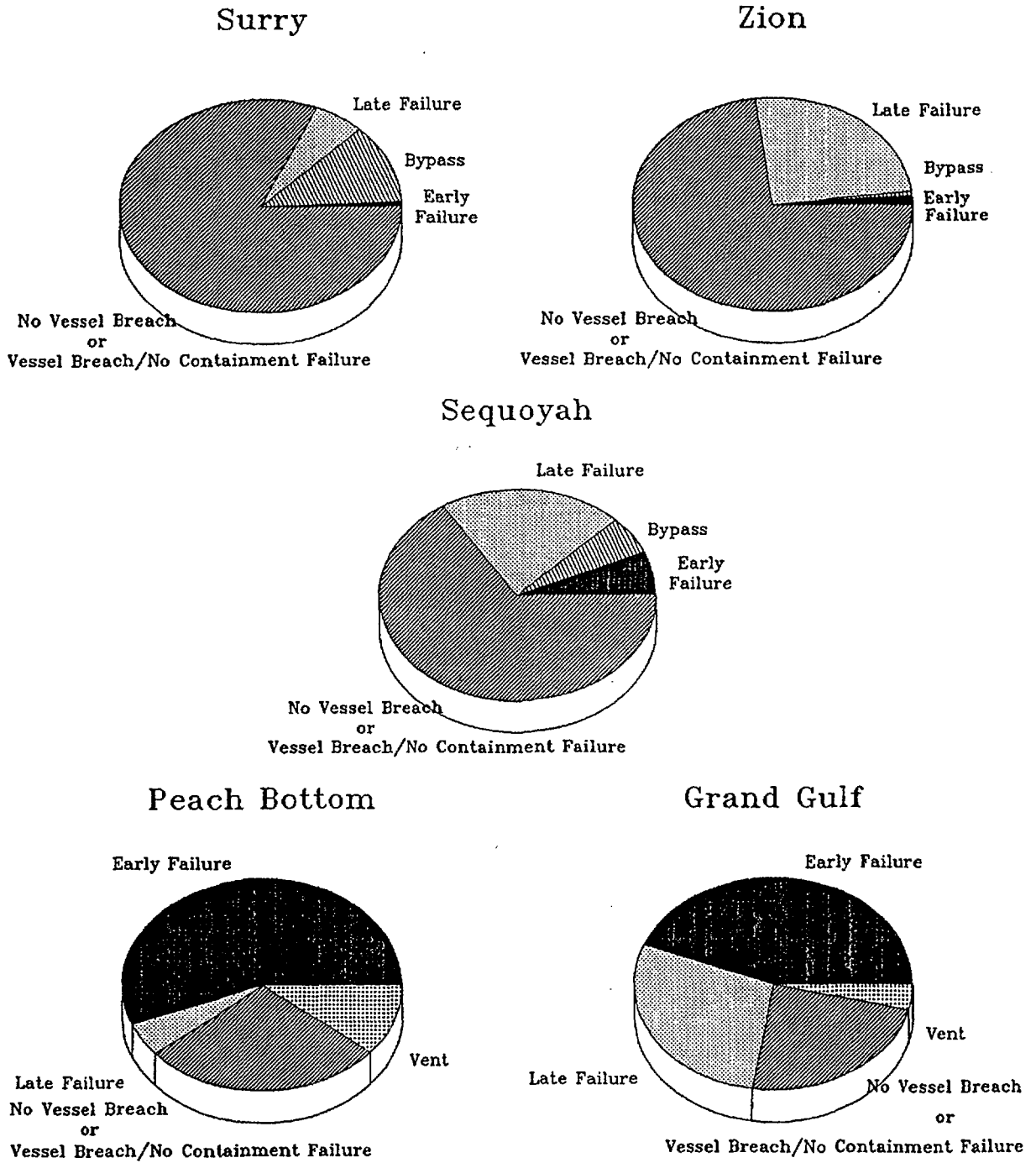
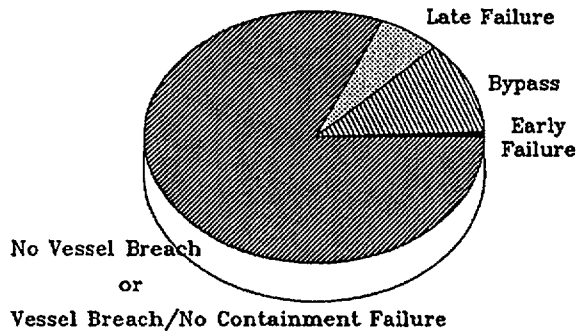
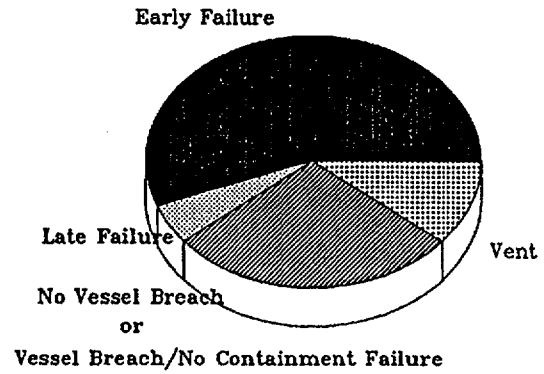

Figure 9.4 Relative probability of containment failure modes (internal events).

Surry - Internal Events



Peach Bottom - Internal Events



Surry - Fire

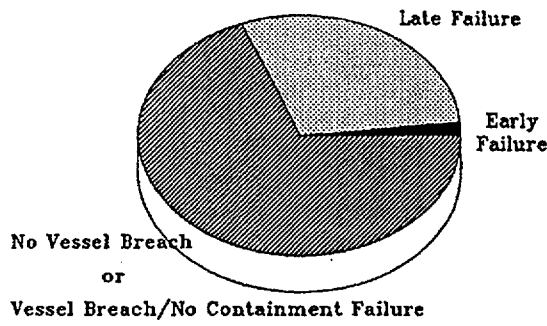

Peach Bottom - Fire

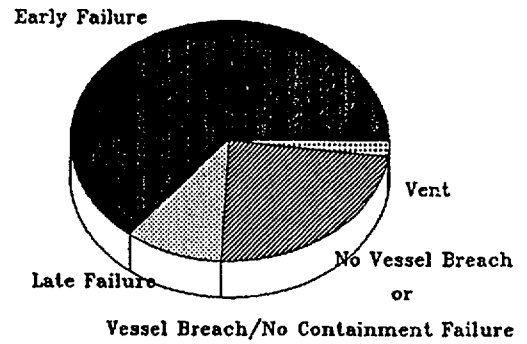

Surry - Seismic

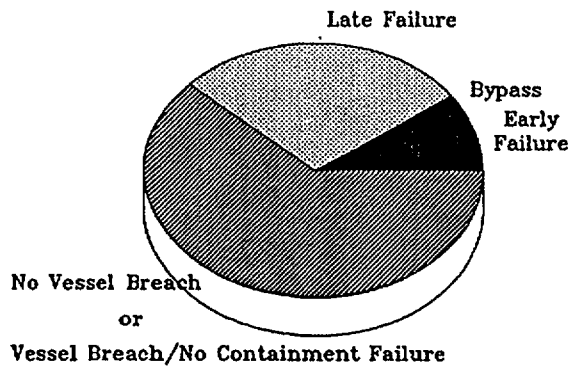

Peach Bottom - Seismic

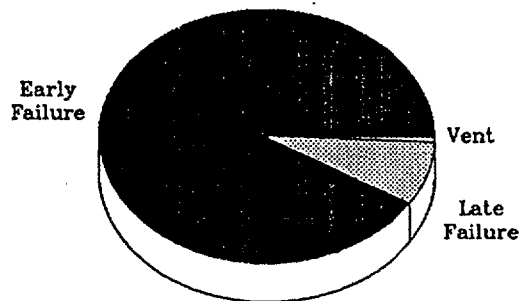

Figure 9.5 Relative probability of containment failure modes (internal and external events, Surry and Peach Bottom).

external-event analysis compared to the internal analysis. In the seismic analysis, the conditional probability of early failure is predicted to increase significantly (to approximately 8 percent). The increased failure likelihood is associated with substantial motion of the reactor coolant system components in an earthquake and resulting damage to the containment. In the fire analysis, there are no externally initiated bypass accidents, the likelihood of bypass induced by overheating of steam generator tubes is assessed to be negligible, and there is only a very slight increase in early containment failure.

Perspectives on the differences between external-event and internal-event containment performance for the Peach Bottom plant are similar to those described for Surry. In the fire analysis, some increase in early containment failure is predicted. In the fire sequences, there is a reduced potential for the recovery of ac power, which results in a reduced probability of injection recovery and an increased likelihood of drywell shell meltthrough.

In the BWR seismic analysis, the probability of containment survival in a severe accident is small; the increased likelihood of early containment failure is the result of substantial motion of the reactor vessel and subsequent damage to the containment during a major earthquake (well beyond the plant's design level) and a reduced recovery potential that increases the likelihood of containment failure as described for the fire sequences.

9.2.3 Additional Summary Results

Based on the results of the five-plant risk analyses summarized in Chapters 3 through 7, and discussed in detail in References 9.2 through 9.6, the following perspectives on containment performance in severe accidents can be drawn.

Zion and Surry Plants (Large, Dry and Subatmospheric Designs)

- Large, dry and subatmospheric containment designs appear to be quite robust in their ability to contain severe accident loads. This study shows a high likelihood of maintaining integrity throughout the early phases of severe accidents in which the potential for a large release of radionuclides is greatest. The uncertainties in describing the magnitude of severe accident loads at vessel breach for pressurized scenarios and the likelihood of

depressurization prior to lower head failure are large, however.

- Containment bypass sequences (severe accidents initiated by steam generator tube ruptures, tube ruptures induced by hot circulating gases, or interfacing-system LOCAs) represent a substantial fraction of high-consequence accidents. The absolute frequency of these types of failure is small, however.
- The potential exists for the arrest of core degradation in a significant fraction of core damage scenarios within the reactor vessel as the result of recovery procedures (such as in the TMI-2 accident). The likelihood of containment failure is very small in these scenarios.
- A substantial likelihood exists that the containment will remain intact even if the accident progresses beyond the point of lower head failure.
- The likelihood of early containment failure in seismic events is higher than for internally initiated accidents.

Sequoyah Plant (Ice Condenser Design)

- The likelihood of early failure in a severe accident for the Sequoyah plant is higher than for the large, dry and subatmospheric designs but is less than for the BWRs analyzed. Early failure is primarily associated with loads imposed at the time of vessel breach (from a number of mechanisms, including direct containment heating and hydrogen combustion).
- Containment rupture from high overpressure loads at the time of vessel breach is likely to result in significant damage to the containment wall and effective bypass of the ice bed.
- Containment bypass is potentially an important contributor to the frequency of a large early release of radioactive material.
- The high likelihood of a deeply flooded reactor cavity plays an important role in mitigating severe accident consequences at Sequoyah. The deeply flooded cavity assists in reducing the loads at vessel breach, in preventing direct attack of molten fuel debris on the containment wall, and in avoiding molten core-concrete interactions.

9. Accident Progression

- There is substantial potential for the arrest of core damage prior to vessel failure. There is, however, some likelihood of containment failure from hydrogen combustion events.
- A substantial likelihood exists for containment integrity to be preserved throughout a severe accident, even if the accident progresses beyond vessel breach.

Peach Bottom Plant (Mark I Design)

- The analyses indicate a substantial likelihood for early drywell failure in severe accident scenarios, primarily as the result of direct attack of the drywell shell by molten core debris.
- Considerable uncertainty exists regarding the likelihood of failure of the drywell as the result of direct attack by core debris. Although this is the dominant failure mechanism in the analyses, other loads on the drywell can lead to early drywell failure, such as rapid overpressurization of the drywell. A sensitivity study was performed in which the drywell meltthrough mechanism of failure was eliminated. The resulting reduction in mean early containment failure probability was from 0.56 to 0.2 (Ref. 9.3).
- The principal benefit of wetwell venting indicated by the study is in the reduction of the core damage frequency. Although venting is not effective in eliminating some early drywell failure mechanisms, venting could eliminate other sequences that would result in overpressure failure of the containment.
- There is substantial potential for the arrest of core damage prior to vessel failure. The likelihood of containment failure in arrested scenarios is small.
- The likelihood of early containment failure is higher for fire and seismic events than internally initiated accidents because of the decreased likelihood of ac and dc recovery resulting in higher drywell shell meltthrough probabilities.

Grand Gulf Plant (Mark III Design)

- Grand Gulf containment was predicted to fail at or before vessel breach in a substantial fraction of severe accident sequences. Hy-

drogen deflagration is the principal mechanism for early containment failure.

- Failure of the integrity of the drywell is predicted to accompany containment failure in approximately one-half the sequences involving early containment failure (resulting in bypass of the suppression pool for radionuclides released after vessel breach). Drywell failure is primarily the result of loads from rapid combustion events prior to reactor vessel breach and loads at vessel breach associated with overpressurization by direct containment heating, ex-vessel steam explosions, and hydrogen combustion in the wetwell region. Scrubbing of releases occurring before vessel breach can still occur in sequences in which the drywell fails and the suppression pool is eventually bypassed.
- There is a large potential for the arrest of core damage prior to vessel failure. If large quantities of hydrogen are produced in the process of recovery, hydrogen combustion could result in containment failure.
- Venting was not found to be particularly effective in preventing containment failure for accident scenarios involving core damage. Furthermore, venting was not as effective in reducing core damage frequency in Grand Gulf as it was in Peach Bottom.

9.3 Comparison with Reactor Safety Study

Prior to the time the Reactor Safety Study (RSS) (Ref. 9.7) analyses were undertaken, there had been no relevant experimentation or modeling of either the loads produced in a severe accident or the response of a containment to loads exceeding the design basis. As a result, the characterization of containment performance in the RSS is simplistic in comparison to the present study.

Containment Failure Modes

Figure 9.6 compares estimates for the present study with those of the RSS for the cumulative failure probability as a function of internal pressure for the Surry plant. The current study indicates that the Surry containment is substantially stronger than did the RSS characterization. In the RSS analyses, failure was assumed to involve rupture of the containment with substantial leakage to the environment. The current study subdivides failure into different degrees of leakage. Failure at the low-pressure end of the range would most

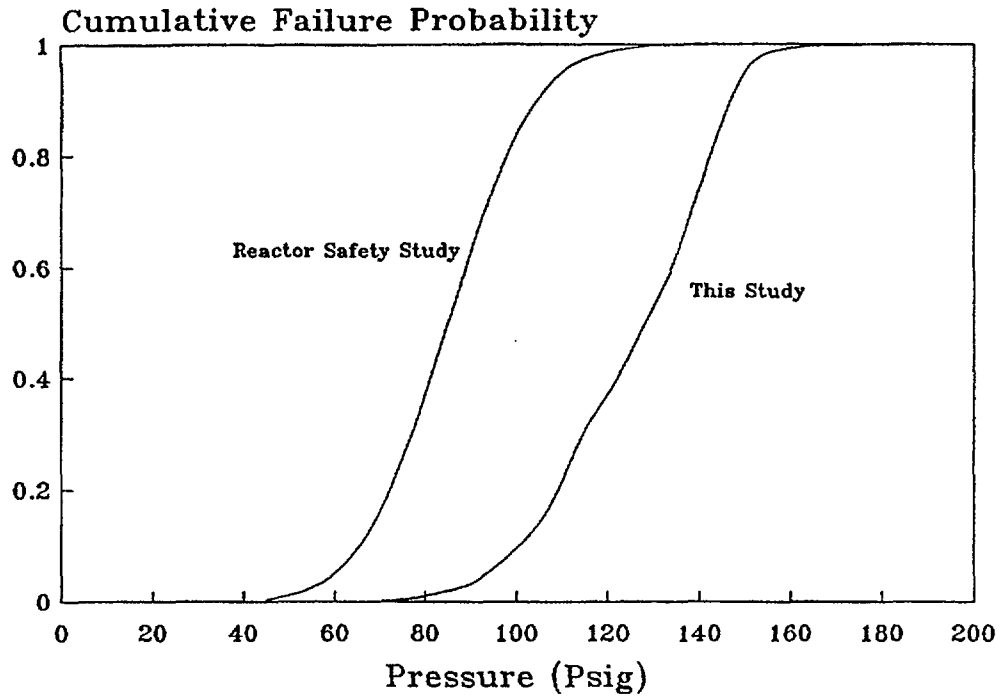

Figure 9.6 Comparison of containment failure pressure with Reactor Safety Study (Surry).

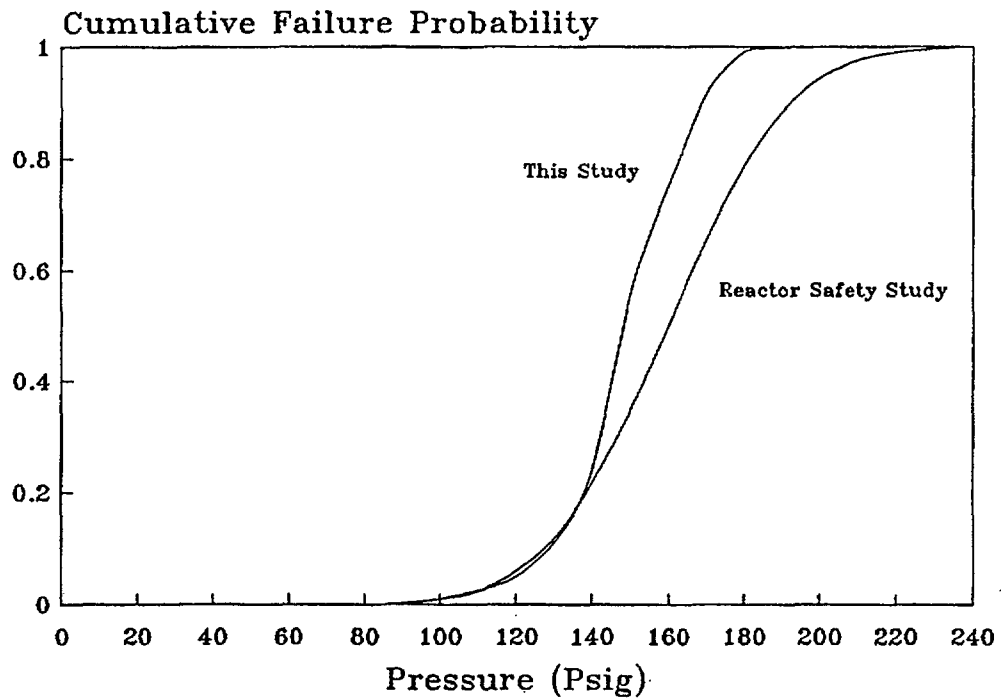

Figure 9.7 Comparison of containment failure pressure with Reactor Safety Study (Peach Bottom).

9. Accident Progression

likely be the result of limited leakage, such as failure at a penetration rather than a substantial rupture of the containment wall. As the failure pressure increases, the likelihood of rupture versus leakage also increases. At pressures close to the ultimate strength of the shell, the potential for gross rupture of the containment exists but was found to be unlikely.

Figure 9.7 compares the current study with RSS estimates for cumulative failure probability as a function of pressure for the Peach Bottom plant (Mark I design). The curves are quite similar, with the current perspective being of a slightly less strong containment than the RSS representation. The curve presented from the current study is representative of a cool drywell (less than 500° F). Cumulative distributions were also developed in the current study for higher drywell temperatures. At 1200° F the median failure pressure was assessed to be 45 psig as opposed to 150 psig at low temperatures.

Failure location in the Mark I design can be as important as failure time. In the RSS, the most likely failure location was assessed to be at the upper portion of the toroidal suppression pool. It was assumed that, following containment failure, the pool would no longer be effective in scrubbing radioactive material. In the current analyses, other mechanisms of containment failure, such as direct attack of the drywell wall by molten core debris, were found to be more important than overpressure failure. The dominant location of overpressure failure is assessed to be the lifting of the drywell head by stretching the head bolts. Gases leaking past the head enter the refueling bay where limited radionuclide retention is expected rather than into the reactor building where more extensive retention could occur. (However, the leakage into the reactor building can also result in severe environments that can cause equipment failure.) Another structural failure from overpressure identified as likely in this study is at the bellows in the downcomer, which would result in leakage from the wetwell vapor space to the reactor building. Thus, although the estimated failure pressures identified in this study and in the RSS are quite similar, the modes and locations of failure are quite different.

Comparison of Surry Results

Risk in the RSS is dominated by a few key sequences for each plant. Containment performance in these sequences was a major aspect of their risk significance. The three key sequences for Surry

were station blackout, an interfacing-system LOCA, and the failure of an instrumentation line penetrating the lower head. Figure 9.8 illustrates the range of early failure probability for station blackout in the current analyses and provides the point estimate from the RSS as a comparison. The RSS estimate of early failure likelihood is substantially higher than the present analysis even though the phenomenon of direct containment heating had not been identified at the time of the RSS. In addition to the lower assumed failure pressure of the containment, the RSS prediction of the rate of containment pressurization was unrealistically high.

The current perspective on the behavior of the interfacing-system LOCA in which the break occurs outside the containment resulting in bypass is essentially the same as in the RSS. The RSS did not identify the potential for rupture of a steam generator tube as a potentially important initiator of a severe accident.

The third important sequence in the RSS, involving an instrumentation line rupture, is no longer considered a core meltdown sequence. In the RSS analyses, if the containment spray injection pumps were to fail, damage was assumed to occur to the spray recirculation pumps resulting in loss of containment heat removal, containment failure, and consequent loss of emergency coolant makeup water to the vessel. More detailed analyses (Ref. 9.8) indicate, however, that condensed steam would provide sufficient water in the containment sump to prevent damage to the recirculation spray pumps, avoiding conditions resulting in containment failure and core meltdown.

Comparison of Peach Bottom Results

In the RSS analyses for the Peach Bottom plant, two sequences dominated the risk: a transient event with loss of long-term heat removal from the suppression pool and an anticipated transient without scram (ATWS). Loss of long-term heat removal is an extended accident in which heating of the suppression pool leads to overpressure failure of the containment and consequent loss of makeup water to the vessel. With the procedures now available to vent the Peach Bottom containment to outside the reactor building, the likelihood of loss of long-term heat removal leading to core meltdown has been reduced to the point where it is no longer a substantial contributor to core damage frequency or risk.

In the RSS analyses, early containment failure was considered a certainty in the ATWS sequence.

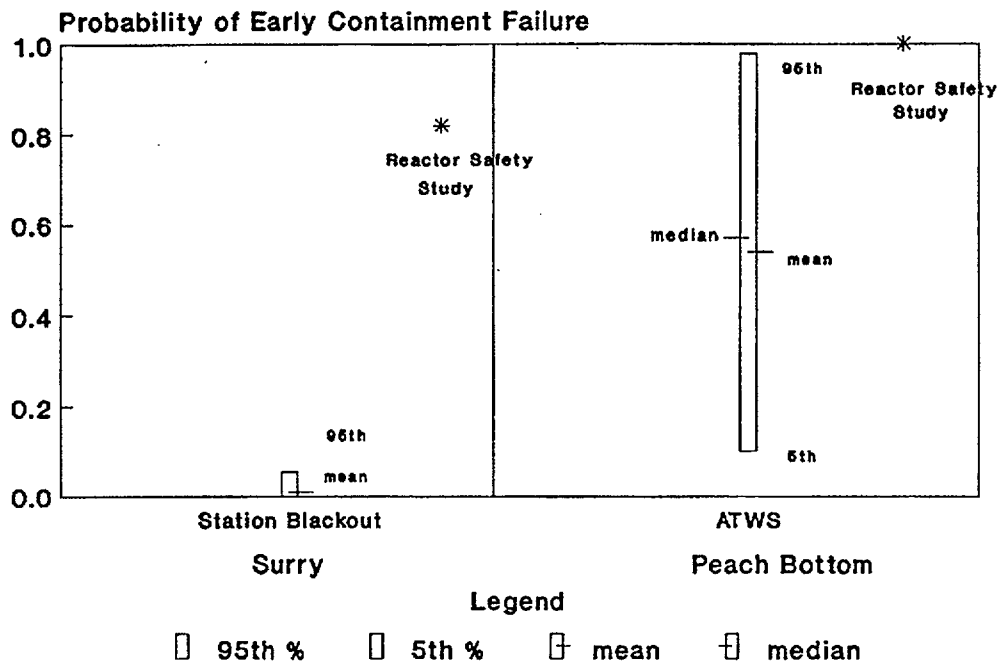

Figure 9.8 Comparison of containment performance results with Reactor Safety Study (Surry and Peach Bottom).

Figure 9.8 indicates that early failure is still considered quite likely for this sequence. The mechanisms resulting in failure and location of failure are different, however.

In summary, changes have occurred in predicting containment performance for the two plants analyzed in the RSS. There have been substantial improvements in the ability to model severe accident phenomena and system behavior in severe accidents. For Surry, the high likelihood of maintaining containment integrity indicated in the present study is the most significant difference in perspective between the two studies.

9.4 Perspectives

9.4.1 State of Analysis Methods

The analysis of severe accident loads and containment response involves substantial uncertainty because of the complexity of core meltdown processes. After a decade of research into severe accident phenomena subsequent to the TMI-2 accident, methods of analysis have been developed that are capable of addressing nearly every aspect of containment loads, including hydrogen defla-

gration and detonation and core-concrete interactions. In some instances, such as direct attack of the Mark I containment shell by molten material and direct containment heating, research is still being pursued (Ref. 9.9). Although the residual uncertainties are in some instances great, the methods are adequate to support meaningful Level 2 PRA analyses.

The accident progression event tree analysis techniques developed for this study involve a very detailed consideration of threats to containment integrity. A number of large computer analyses were required to support the quantification of event probabilities at each branch of the event tree. The analysis team for this study had the considerable advantage of access to researchers involved in the development and application of computer codes used in the analysis of core melt progression, core-concrete attack, containment behavior, radionuclide release and transport, and hydrogen combustion.

Computer analyses cannot, in general, be used directly and alone to calculate branching probabilities in the accident progression event tree. Since the greatest source of uncertainty is typically associated with the modeling of severe accident

phenomena, the results of a single computer run (which uses a specific model) do not characterize the branching uncertainty. It is therefore necessary to use sensitivity studies, uncertainty studies, and expert judgment to characterize the likelihood of alternative events that affect the course of an accident. The effort undertaken in this study to elicit expert opinion was substantial. The expense of the overall accident progression analysis techniques (expert elicitation and computer analysis to support event tree quantification) employed in this study is currently a drawback to their widespread use. However, methods to apply the models, the distributions, and the computer codes to other plants at a reasonable cost are under study.

9.4.2 Important Mechanisms That Defeat Containment Function During Severe Accidents

The challenges to containment integrity that would occur in a severe accident depend on the nature of the accident sequence, as well as the design of the plant. The various containment designs analyzed in this study responded differently to different severe accident challenges.

Containment Bypass and Isolation Failure

When an accident occurs, a number of valves must close to isolate the containment from the environment. On the basis of absolute frequency, failure to isolate the containment was not found to be a likely source of containment failure for any of the plants analyzed. Primarily because of the low frequency of early containment failure by other means, containment isolation failure is a relatively important contributor to early failure at Zion. The subatmospheric containment and nitrogen-inerted Mark I containments are particularly reliable in this regard since it is highly likely that leakage would be identified during operation.

Containment bypass is an important contributor to large early releases of radionuclides for the Surry (subatmospheric), Sequoyah (ice condenser), and Zion (large, dry) containment designs. The principal contributors are accidents initiated by interfacing-system LOCAs and by steam generator tube ruptures. The predicted frequency of these events is quite small, however, and their dominance of risk is the result of the relatively lower frequency of other means to obtain large early releases.

Gas Combustion

Hydrogen and carbon monoxide are the two combustible gases potentially produced in large quanti-

ties in severe accidents. The principal source of hydrogen is the reduction of steam by chemical reaction of metals, particularly zirconium and iron. Carbon monoxide would only be produced in the later stages of an accident involving the attack of concrete by molten core debris. Because of the timing of carbon monoxide release, its production does not represent a threat of early failure to the containment but can contribute to delayed failure.

Rapid gas combustion was not found to be a substantial threat to containment for the Surry (subatmospheric), Zion (large, dry), or Peach Bottom (Mark I) containments. The Surry and Zion designs are sufficiently robust to survive deflagrations (rapid burning). At Surry and Zion, the likelihood of global detonations that could fail the containment (by impulsive loads) was assessed to be small. The contribution of hydrogen combustion to the pressure rise in the containment at the time of vessel failure in the event of high-pressure melt ejection of molten fuel was considered, but the likelihood of early failure of containment was also assessed to be small.

Hydrogen combustion is not a threat to the Mark I design because it normally operates with a nitrogen-inerted containment and thus has insufficient oxygen concentration to support combustion.

Hydrogen combustion was found to be a substantial threat to the integrity of the Sequoyah (ice condenser) and Grand Gulf (Mark III) designs. A very small contribution, about 1 percent, to early failure from hydrogen combustion prior to vessel breach is predicted for the station blackout sequences in Sequoyah. In arrested sequences, the containment failure probability is increased 5 percent because of ignition sources from the recovery of ac power. Approximately 12 percent mean early containment failure probability arises at the time of vessel breach, largely as the result of hydrogen combustion.

For the Grand Gulf plant, there is a substantial likelihood of containment failure before vessel breach in the short-term station blackout sequence because of the unavailability of igniters. At the time of vessel breach, hydrogen combustion loads can again occur, which can fail the containment (the percentages of containment failure before and at vessel breach are similar). Two additional reasons combine to make hydrogen events extremely important at Grand Gulf: (1) the BWR core contains an extremely large amount of zirconium that is available for hydrogen production, and (2) the suppression pool is subcooled in the

short-term station blackout sequences resulting in condensation of the steam from the drywell or the vessel and leading to hydrogen-rich mixtures in the containment that are readily ignited.

Loads at Vessel Failure

The increase in containment pressure that could occur at vessel failure represents an important challenge to containment for each of the five designs (see Appendix C). In the Zion (large, dry) and Surry (subatmospheric) designs, loads at vessel breach from high-pressure melt ejections (rapid transfer of heat from dispersed core debris accompanied by chemical reactions with unoxidized metals in the debris) represent a mechanism that can result in containment loads high enough to fail containment. The predicted likelihood of failure for these scenarios in the Surry and Zion designs was found to be small, in part because most high-pressure sequences were predicted to depressurize by one or more means prior to vessel failure and because the overlap between the containment load distribution and the containment failure distribution was small.

Although loads at vessel breach have been studied more extensively for PWR containments, they were found to be an important contributor to early containment failure in the Sequoyah (ice condenser) and Peach Bottom (Mark I) plants and to early drywell failure in Grand Gulf (Mark III). In the Sequoyah and Grand Gulf analyses, hydrogen combustion is also a principal contributor to early containment failure from the loads at vessel breach. At Grand Gulf, pedestal failure, due to dynamic loads from ex-vessel steam explosions or subcompartment pressure differential, can also result in drywell failure at this stage of the accident.

Direct attack of the drywell shell is the dominant failure mechanism at vessel breach in the Peach Bottom plant. Overpressurization can also lead to leakage failure in the drywell by lifting the drywell head or to failure in the wetwell.

Direct Attack by Molten Debris

Direct attack of the drywell wall by molten debris in the Peach Bottom (Mark I) design has been the subject of considerable controversy among severe accident experts (see Section C.7 of Appendix C). Essentially half the experts whose opinions were elicited believed that containment failure would occur, and half believed that it would not occur. The numerical aggregation of these diverse views led to a mean likelihood of failure in the

present analysis of approximately 30 percent when the pedestal region is wet and 80 percent when the pedestal region is dry (Ref. 9.3).

Molten debris attack was also predicted to be a threat to the Sequoyah (ice condenser containment) in high-pressure sequences in which molten debris could be dispersed into the seal table room, which is outside the crane wall and adjacent to the steel wall of the containment. The likelihood of failure was considerably less than for Peach Bottom, however.

Steam Explosions

When molten core material contacts water, the potential exists for rapid transfer of heat, production of steam, and transfer of thermal energy to mechanical work. Considerable research has been undertaken to determine the conditions under which steam explosions can occur and their energetics. At pressures near atmospheric, it is generally concluded that steam explosions would be likely if molten core material drops into a pool of water. However, the energetics and coherence of the molten fuel-coolant interaction are very uncertain. At high steam pressure, steam explosions are found to be more difficult to initiate.

Steam explosions represent a variety of potential challenges to the containment. If the interaction were to occur in the reactor vessel at the time when molten core material slumps into the lower plenum, the possibility exists of tearing loose the upper head of the vessel, which could impact and fail the containment (this has been called the "alpha mode" of containment failure since the issuance of the RSS). The analyses in this study indicate that the potential for this type of event to result in early containment failure is less than 1 percent for each of the plants. For Surry and Zion, steam explosions represent a significant fraction of the early failure probability, but only because the overall likelihood of early failure is small.

When molten core material drops into water outside the vessel, the potential failure mechanisms are different. In the Grand Gulf plant, a shock wave could propagate through water and impact the concrete structure that provides support to the reactor vessel. Substantial motion of the vessel could then lead to the tearout of penetrations through the drywell wall. Because of the shallow water pool at Peach Bottom, dynamic loads from steam explosions do not represent a similar mechanism for failures.

9. Accident Progression

In addition to potentially producing missiles and shock waves, steam explosions can also rapidly generate large quantities of steam and hydrogen. The steam produced from molten fuel-coolant interactions ex-vessel following vessel breach is an important contributor to the static drywell overpressure failure in the Grand Gulf and Peach Bottom plants.

Gradual Overpressurization

Figure 9.9 illustrates the assessed pressure capability for the five plants analyzed. The ability of a containment to withstand the production of gases in a severe accident depends on the volume of the containment as well as its failure pressure. One of the principal sources of pressurization in a severe accident is steam production. In each plant design, however, engineered safety features are present to condense steam in the form of suppression pools, ice beds, sprays, air coolers, or in some designs, combinations of these systems. Steam pressurization is only a major contributor to the total pressure if, in the scenario being analyzed, the heat removal system has become inoperative; e.g., the spray system has failed, the suppression pool has become saturated, or the ice has melted.

Large quantities of hydrogen are predicted to be released in severe accidents, both in-vessel during the melting phase and ex-vessel during core-concrete attack, debris bed quenching, or high-pressure melt ejection. If the hydrogen does not burn, it will contribute to the containment pressure. Carbon monoxide and carbon dioxide produced during core-concrete attack also contribute to containment pressurization.

Because of its relatively small volume, the Peach Bottom (Mark I) design is more vulnerable to overpressurization failure by noncondensable gas generation. If the accident progression proceeds to vessel penetration and the molten core attacks the concrete, it is unlikely that containment integrity can be maintained in the long term unless other factors mitigate gas production.

Overheating

The effect of high temperature in the drywell on containment failure probability and mode was considered in the Peach Bottom analysis. Although very high gas temperatures can be achieved as the result of hydrogen combustion in the other plant designs, the structure temperatures are not predicted to reach temperatures at which the strength of the structure would be substantially reduced or sealant materials would be degraded.

The Peach Bottom drywell, however, is relatively small. Substantial convective and radiative heat transfer from hot core debris could result in very high drywell wall temperatures. Failure could result from the combination of high pressure in the drywell and decreased strength of the steel containment wall. Overheating the drywell is only a contributor to scenarios in which the drywell spray is inoperative. If the sprays are operational, the drywell temperature will be much lower than for the dry case.

Drywell heating in the Peach Bottom plant represents a delayed containment failure mechanism. Since the likelihood of early failure by other mechanisms is high, drywell overtemperature failure is not a substantial contributor to risk.

Loss of Vessel Support

In the earlier section on steam explosions, a mechanism was described for drywell failure in the BWR designs in which structural failure of the reactor pedestal results in vessel motion (tipping or falling) and the tearout of piping penetrations through the drywell wall. Quasistatic pressurization of the pedestal region can result in the same phenomenon. Erosion of the pedestal by molten core attack of the concrete can also lead to the same effect. In this event, however, considerable time is required for the erosion to occur, and the failure would be late and the importance to risk is diminished. The likelihood of this mechanism of failure is generally small for the BWRs analyzed, in part because other mechanisms are likely to result in failure earlier in the accident.

Basemat Melthrough

For each of the five plants analyzed, some potential exists for core debris to be quenched as a particulate debris bed and cooled in the reactor cavity or pedestal region if a continuous source of water is available. A significant likelihood exists, however, that, even if a replenishable water supply is available, molten core debris will attack the concrete basemat. If the core-concrete interaction does occur, the presence or absence of an overlying water pool is not expected to have much effect on the downward progression of the melt front.

The depth of the basemat of the Peach Bottom containment, directly under the vessel, is so great that it is unlikely that the basemat would be penetrated before the occurrence of other failure modes. For the other plants, basemat penetration is possible, but the projected consequences are minor in comparison with those of aboveground failures.

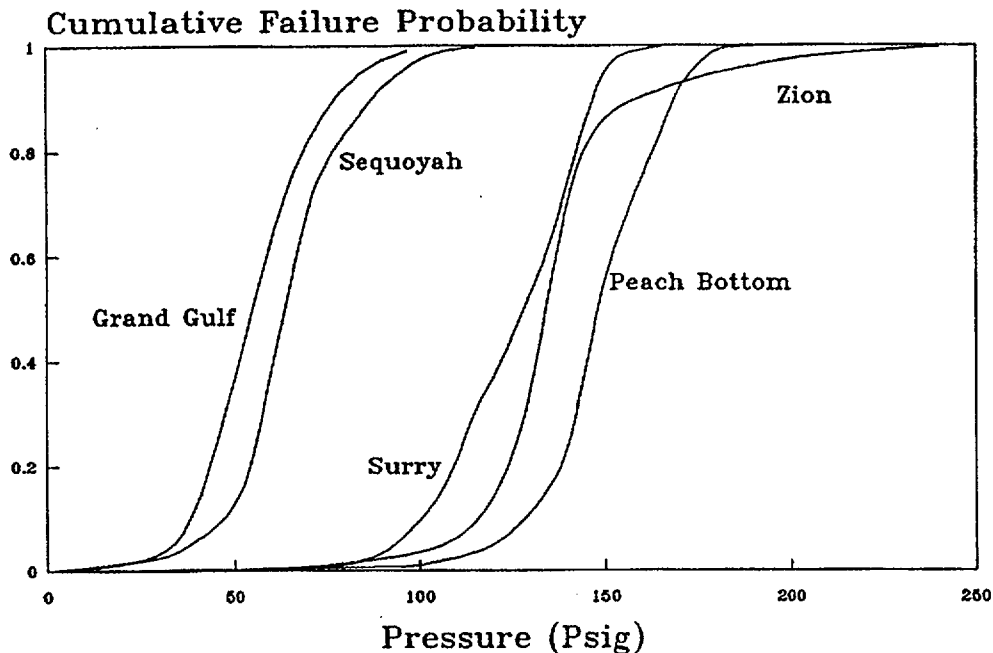

Figure 9.9 Cumulative containment failure probability distribution for static pressurization (all plants).

9.4.3 Major Sources of Uncertainty

The perspectives on the major sources of uncertainty described in this section come from four sources:

- Regression analysis-based sensitivity analyses for the mean values for risk. Simple linear regression models were used to represent the complex risk models, and adequate results were obtained. Better results would require more complex regression models. Insights for this section are deduced from the risk regression studies (regression analyses for conditional containment failure probabilities required for more detailed accident progression insights were not performed). Results of these studies are presented in References 9.2 through 9.6.
- Partial rank correlation analyses for the risk complementary cumulative distribution functions. Results of these studies are presented in References 9.2 through 9.6.
- Sensitivity studies in which separate analyses were performed with certain parameter val-

ues set to a specific value. Sensitivity studies were performed on the Mark I drywell shell meltthrough issue and the PWR RCS depressurization scenarios. These studies were only performed for the accident progression analysis; no source term or consequence insights are available.

- The subjective judgment of the analysts performing the plant-specific studies.

Importance of Accident Progression Analysis Variables to Rank Regression Analyses for Annual Risk

The majority of the variables important to the rank regression analyses performed for Surry were the initiating event frequencies of the containment bypass events and the source term variables. The only accident progression event tree variable that was demonstrated to be important to the uncertainty in risk for internal events was the probability of vessel and containment breach by an in-vessel steam explosion; this variable was moderately important to the uncertainty in total early fatality risk (Ref. 9.2).

The regression analyses performed for Sequoyah showed the containment failure pressure and

9. Accident Progression

loads at vessel breach to be accident progression variables somewhat important to the uncertainty in both total early fatality risk and total latent cancer fatality risk (Ref. 9.4).

The probability of drywell meltthrough was the only accident progression variable that was at all important to uncertainty in the early fatality risk or the latent cancer fatality risk for the internal regression analysis for Peach Bottom (Ref. 9.3).

The amount of hydrogen produced in-vessel, the probability of drywell failure following pedestal failure, the pressure load in the drywell at vessel breach, and the amount of hydrogen produced and released at and shortly after vessel breach were accident progression variables that were found to be important to the uncertainty in early fatality risk by the Grand Gulf regression analyses. The probability of drywell failure following pedestal failure and the pressure load in the drywell at vessel breach were found to be important to the uncertainty in latent cancer fatality risk (Ref. 9.5).

The majority of variables important to the rank regression analyses performed for Zion were related to failure or recovery of the component cooling water (CCW) system and the source term variables. The only accident progression event tree variable that was demonstrated to be important to the uncertainty in risk was the probability of vessel and containment breach by an in-vessel steam explosion. This result was also obtained from the Surry regression analyses. The probability of a steam explosion failure was found to be important to the uncertainty in both early and latent health risk measures at Zion. The importance of seal LOCA failure to risk uncertainty was expected, given the large contribution of these events to the core damage frequency. Upgrades to the Zion service water and CCW systems have the potential to reduce the importance of these events as discussed in Appendix C (Section C.15) (Ref. 9.6).

Direct Attack of Drywell Shell in Peach Bottom

The divergence of opinion of the panel of containment performance experts, in itself, is an indicator of the uncertainty in the associated phenomena. A sensitivity study was performed to determine the impact on containment performance of eliminating this failure mechanism. The mean early failure probability (averaged over all sequences) was reduced from 56 percent to 20 percent (Ref. 9.3).

High-Pressure Melt Ejection and Vessel Depressurization

For the Surry and Zion plants, early containment failure resulting from loads at vessel breach is assessed to have low probability, on the order of 1 percent. Sensitivity studies were performed to determine the dependence of this result on expert judgments made about various reactor coolant system depressurization mechanisms prior to vessel breach. A sensitivity study was performed for Surry (Ref. 9.2), which removed depressurization by temperature-induced breaks. This study indicated that removal of only temperature-induced failures for depressurization does not result in a significant increase in the likelihood of early containment failure (from roughly 1 percent to roughly 2 percent). This probability study, therefore, implies that other depressurization mechanisms, such as the failure of reactor coolant pump seals and stuck-open relief valves, are also important. However, a sensitivity study was also performed for Zion (Ref. 9.6) in which all depressurization mechanisms were removed. The result of this study was a relatively small increase in the likelihood of early containment failure. For accidents initiated by LOCAs (which dominate the estimated core damage frequency), this change resulted in essentially no change in the conditional probability of early containment failure. The probability of early failure increased by a factor of 5 for accidents initiated by transients (from roughly 0.01 to 0.06) and by a factor of 2 for accidents initiated by station blackout (from roughly 0.03 to 0.06). The reason for the relatively small impact of removing all depressurization mechanisms on the probability of early containment failure is that the Zion containment is expected to withstand high-pressure melt ejection loads (even at the upper end of the uncertainty range) with very high confidence (refer to Section C.5 of Appendix C for a more detailed discussion). Also, at these small probability levels, in-vessel steam explosions contribute to the likelihood of early containment failure. If the reactor coolant system pressure remains high, the likelihood of triggering a steam explosion is decreased. Thus, the slightly higher probability of early containment failure resulting from high-pressure melt ejection loads will be offset to some degree by the lower probability of containment failure from in-vessel steam explosions.

Uncertainties associated with high-pressure melt ejection also affect the early containment failure likelihood for the other three plants. The significance of this issue is greatest for the Sequoyah and Grand Gulf plants, which have lower over-pressure capacity and which are vulnerable to the

hydrogen produced in the oxidation of dispersed core debris by steam.

Containment Failure by Steam Explosions

The production of missiles by in-vessel steam explosions only appears as a significant contributor to early failure or bypass in the Zion analyses. The contribution of alpha-mode containment failure is the result of the very low probability of other modes of early failure or bypass and is itself a low value. Quasistatic and shock loading from an ex-vessel steam explosion is indicated to be a potentially important contributor to drywell failure for Grand Gulf. Ex-vessel steam explosions also contribute to quasistatic overpressurization failure in the Peach Bottom plant.

Core Melt Progression

Many of the uncertain phenomena that have the potential to lead to early containment failure (e.g., high-pressure melt ejection, drywell shell at-

tack, steam explosions, and hydrogen generation) are sensitive to the details of core melt progression, particularly the later stages of progression in which molten core material enters the lower head of the vessel. The mass of material potentially available for dispersal at head failure, the composition of this material, the timing of head failure, and the mode of head failure have a substantial indirect impact on the likelihood of early containment failure through their effects on early failure mechanisms.

Containment Bypass

The containment bypass sequences have been discussed throughout this report as special scenarios (in which the containment function has failed) and will be briefly mentioned here. The containment bypass initiating event frequencies, transmission factors, and decontamination factors were demonstrated to be the variables most important to the uncertainty in all risk measures in both the Surry and Sequoyah rank regression analyses.

REFERENCES FOR CHAPTER 9

- 9.1 M. Silberberg et al., "Reassessment of the Technical Bases for Estimating Source Terms," United States Nuclear Regulatory Commission (USNRC) Report NUREG-0956, July 1986.
- 9.2 R. J. Breeding et al., "Evaluation of Severe Accident Risks: Surry Unit 1," Sandia National Laboratories, NUREG/CR-4551, Vol. 3, Revision 1, SAND86-1309, October 1990.
- 9.3 A. C. Payne, Jr., et al., "Evaluation of Severe Accident Risks: Peach Bottom Unit 2," Sandia National Laboratories, NUREG/CR-4551, Vol. 4, Draft Revision 1, SAND86-1309, to be published.*
- 9.4 J. J. Gregory et al., "Evaluation of Severe Accident Risks: Sequoyah Unit 1," Sandia National Laboratories, NUREG/CR-4551, Vol. 5, Revision 1, SAND86-1309, December 1990.
- 9.5 T. D. Brown et al., "Evaluation of Severe Accident Risks: Grand Gulf Unit 1," Sandia National Laboratories, NUREG/CR-4551, Vol. 6, Draft Revision 1, SAND86-1309, to be published.*
- 9.6 C. K. Park et al., "Evaluation of Severe Accident Risks: Zion Unit 1," Brookhaven National Laboratory, NUREG/CR-4551, Vol. 7, Draft Revision 1, BNL-NUREG-52029, to be published.*
- 9.7 USNRC, "Reactor Safety Study—An Assessment of Accident Risks in U.S. Commercial Nuclear Power Plants," WASH-1400 (NUREG-75/014), October 1975.
- 9.8 R. S. Denning et al., "Radionuclide Release Calculations for Selected Severe Accident Scenarios—PWR, Subatmospheric Containment Design," Battelle Columbus Division, NUREG/CR-4624, Vol. 3, BMI-2139, July 1986.
- 9.9 USNRC, "Revised Severe Accident Research Program Plan: Fiscal Year 1990-1992," NUREG-1365, August 1989.

*Available in the NRC Public Document Room, 2120 L Street NW., Washington, DC.

10. PERSPECTIVES ON SEVERE ACCIDENT SOURCE TERMS

10.1 Introduction

Shortly after the accident at Three Mile Island, the NRC initiated a program to review the adequacy of the methods available for predicting the magnitude of source terms for severe reactor accidents. After considerable effort and extensive peer review, the NRC published a report entitled "Reassessment of the Technical Bases for Estimating Source Terms," NUREG-0956 (Ref. 10.1). The report recommended that a set of integrated computer codes, the Source Term Code Package (STCP) (Ref. 10.2), be used as the state-of-the-art methodology for source term analysis provided that uncertainties were considered. The STCP methodology provided a starting point for source term estimates in this study. In addition, the characterization of source term uncertainties was supported by calculations with other system codes such as MELCOR (Ref. 10.3) and MAAP (Ref. 10.4), detailed special purpose codes such as CONTAIN (Ref. 10.5), as well as small codes written for this project to examine specific source term phenomena. Because it was impractical to perform an STCP calculation for each source term required and the STCP does not contain models for all potentially important phenomena, simplified methods of analysis were developed with adjustable parameters that could be benchmarked against the more detailed codes. Probability distributions, which had been developed from the elicitations of the source term panel of experts, were provided for many of the parameters in the simplified computer codes. A large number of source term estimates were generated for each plant by sampling from the probability distributions in the simplified codes.

Source terms are typically characterized by the fractions of the core inventory of radionuclides that are released to the environment, as well as the time and duration of the release, the size distribution of the aerosols released, the elevation of the release, the warning time for evacuation, and the energy released with the radioactive material. All these parameters are required for input to the MACCS (Ref. 10.6) consequence code. Although the illustrations and comparisons of source terms in this chapter emphasize the magnitude of estimated release, it is important to recognize that the other characteristics of the source term noted above, such as the timing of release, can also have an important effect on the ultimate consequences.

It is widely believed that the approximate treatment of source term phenomena in the Reactor Safety Study (RSS) (Ref. 10.7) analyses led to a substantial overestimation of severe accident consequences and risk. The current risk analyses provide a basis for understanding the differences that exist in source terms calculated using the new methods relative to those calculated using the RSS methods and the impact of these differences on estimated risk.

10.2 Summary of Results

Some examples of source terms (fractions of the core inventory of groups of radionuclides released to the environment) were provided for accident progression bins for each of the analyzed plants in Chapters 3 through 7. As expected, the magnitude of the source term varies between different accident progression bins depending on whether or not containment fails, when it fails, and the effectiveness of engineered safety features (e.g., BWR suppression pool) in mitigating the release. However, within an accident progression bin, which represents a specific set of accident progression events, the uncertainty in predicting severe accident phenomena is great.

In Figure 10.1, the predicted frequency of radioactive releases is compared among the five plants. In this figure, the mean distribution is presented, allowing differences in plant behavior to be illustrated. The y-coordinate in the figure represents the predicted frequency with which a given magnitude of release (the x-coordinate) would be exceeded. The location of the exceedance curve is determined by the frequencies of accident sequences in addition to the spectrum of possible source terms for those sequences.

It is not obvious in examining a radionuclide source term what the potential health impact would be to the public from a specified magnitude of release. Based on the compilation of a number of consequence analyses, however, one method (Ref. 10.8) has been developed that provides an approximate relationship for the minimum fractions of radionuclides released that result in early fatalities or early injuries. For the release of iodine, for example, the thresholds for early fatalities and early injuries occur at release fractions of the core inventory of approximately 0.1 and 0.01, respectively. Figure 10.1 does not indicate major differences in the exceedance curves for the five plant analyses. For the iodine group,

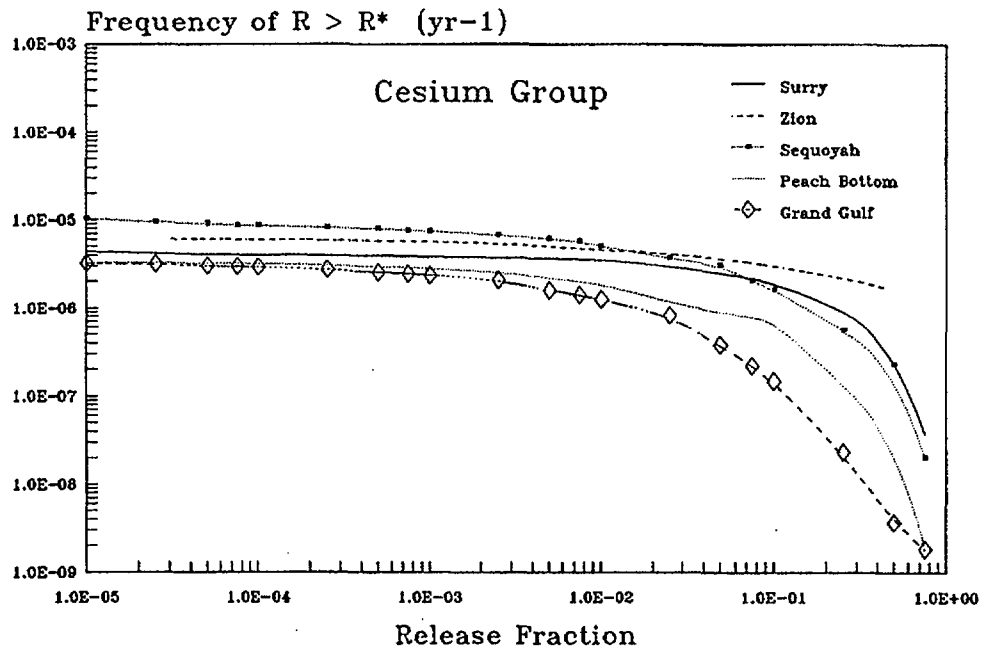
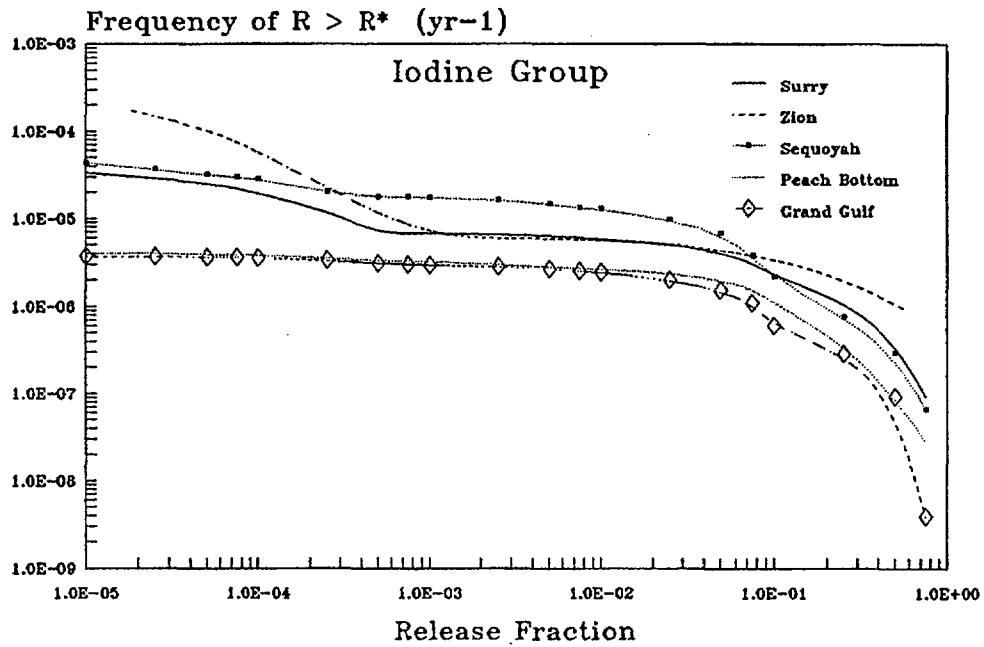

Figure 10.1 Frequency of release for key radionuclide groups.

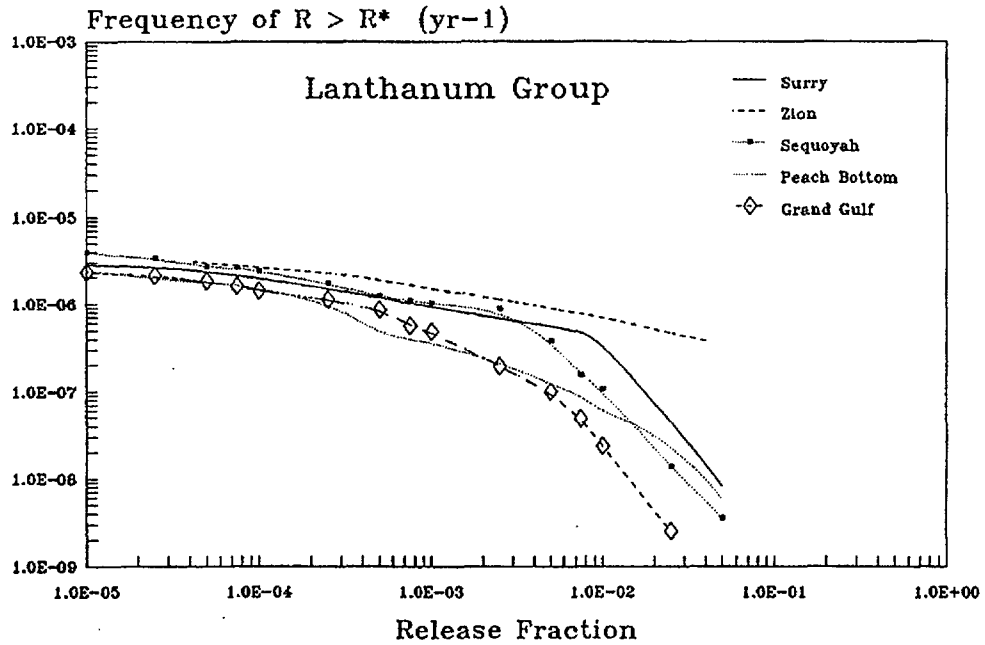
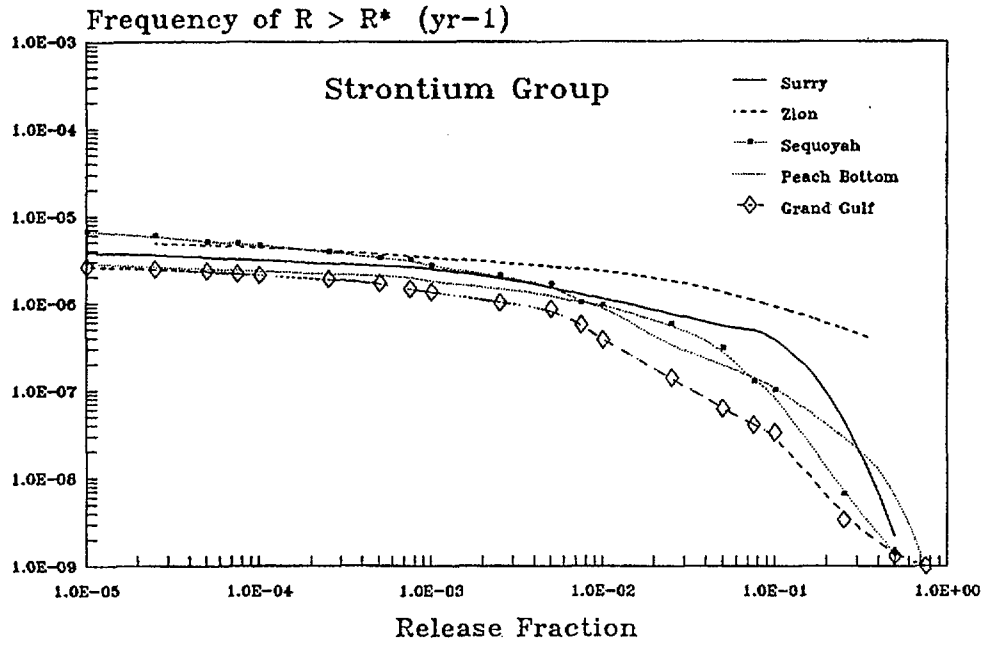

Figure 10.1 (Continued)

10. Severe Accident Source Terms

the frequency of exceeding a release fraction of 0.1 ranges from $1E-6$ to $5E-6$ per reactor year for the five plants. Similarly, for a release fraction of 0.01, the exceedance curves range from $2E-6$ to $1E-5$ per reactor year. The most outstanding feature of these curves is their relative flatness over a wide range of release fractions. For the iodine, cesium, and strontium groups, the curves decrease only slightly over the range of release fractions from $1E-5$ to $1E-1$ and then fall rapidly from 0.1 to 1. For the lanthanum group, the rapid decrease in the curve occurs at a release fraction that is approximately a decade lower. As a result of the flatness of the exceedance curves, the frequency of accidents with source terms that are marginally capable of resulting in early fatalities is only slightly less than the frequency of accidents covering a very broad spectrum of health consequences up to the occurrence of fatalities. However, the frequency of source terms with the potential for multiple early fatalities falls rapidly with increased release.

Based on the results of the source term analyses for the five plants, a number of general perspectives on severe accident source terms can be drawn:

- The uncertainty in radionuclide source terms is large and represents a significant contribution to the uncertainty in the absolute value of risk. The relative significance of source term uncertainties depends on the plant damage state.
- Source terms for bypass sequences, such as accidents initiated by steam generator tube rupture (SGTR), can be quite large, potentially comparable to the largest Reactor Safety Study source terms.
- Early containment failure by itself is not a reliable indicator of the severity of severe accident source terms. Substantial retention of radionuclides is predicted to occur in many of the early containment failure scenarios in the BWR pressure-suppression designs, particularly for the in-vessel period of release during which radionuclides are transported to the suppression pool. Containment spray system and ice condenser decontamination can also substantially mitigate accident source terms.
- Flooding of reactor cavities or pedestals can eliminate the core-concrete release of radionuclides, if a coolable debris bed is formed, or can significantly attenuate the release from

the molten core-concrete interaction by scrubbing in the overlaying pool of water.

10.3 Comparison with Reactor Safety Study

In the Reactor Safety Study (RSS) (Ref. 10.7), source terms were developed for nine release categories ("PWR1" to "PWR9") for the Surry plant and five release categories for the Peach Bottom plant ("BWR1" to "BWR5"). The RSS release categories are directly analogous to the accident progression bins in the current study in that they are characterized by aspects of accident progression and containment performance that affect the source term. For example, the PWR1 release category represented early containment failure resulting from an in-vessel steam explosion with containment sprays inoperative. A point estimate for release fractions (fraction of the core inventory of an elemental group released to the environment) for seven elemental groups (in the current study, the number of elemental groups has been expanded to nine) was then used to represent this type of release.

In the current study, source terms were developed for a much larger number of accident progression bins. A distribution of release fractions was also obtained for each of the elemental groups corresponding to the individual sample members of the uncertainty analysis.

In order to simplify the presentation in this report, the results of similar accident progression bins have been aggregated to a level that is comparable to that used in the RSS. Figure 10.2 provides a comparison of an important large release category (PWR2) from the RSS for Surry with a comparable aggregation of accident progression bins (early containment failure, high reactor coolant system pressure) from the current study.* Also shown in Figure 10.2 is a low release category from the RSS (PWR7) with a comparable aggregation of accident progression bins from the current study (late failure). No range is shown for the noble gas release for this study because no permanent retention mechanisms were assumed to affect these gases. The point estimates of the release of radionuclides in the RSS early containment failure bin are more representative of the upper bounds

*Because of the aggregation of accident progression bins, some of the range of the source terms represents variation in accident progression as well as modeling uncertainty. The distribution was developed from all of the sample members within the aggregated bins without consideration of the relative frequencies of these bins.

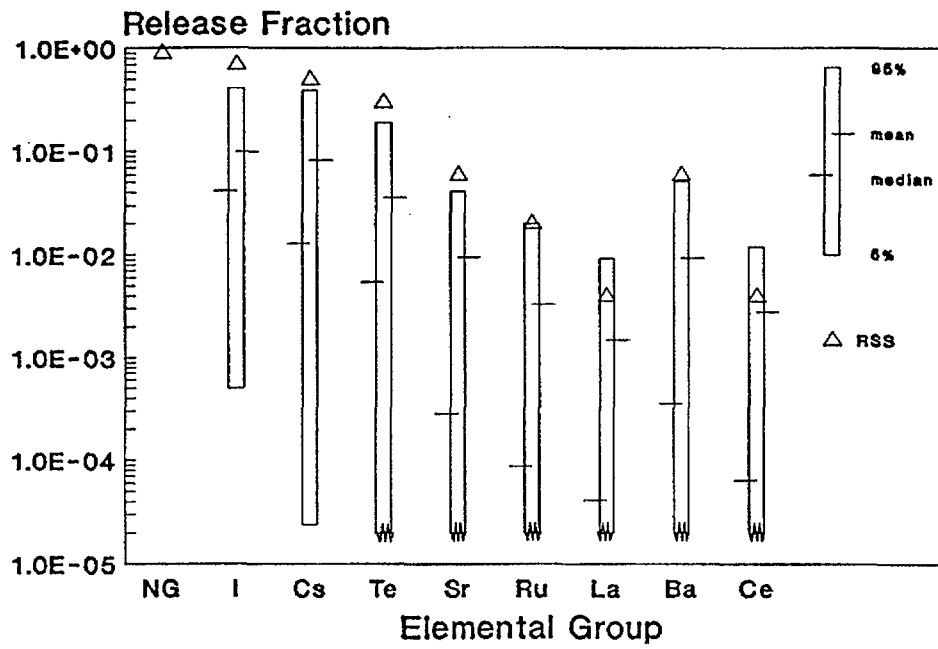

a. Comparison with Bin PWR2

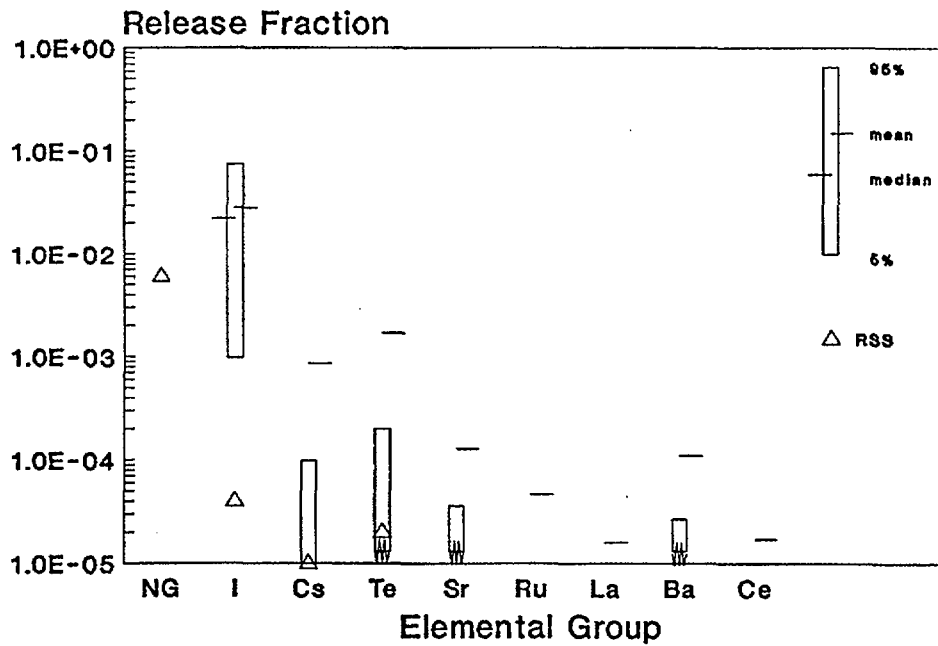

b. Comparison with Bin PWR7

Figure 10.2 Comparison of source terms with Reactor Safety Study (Surry).

10. Severe Accident Source Terms

of the range in the current study than the mean or the median. For the late failure comparison, the results for this study are somewhat higher than those obtained for the RSS. The difference is related to the types of failures in the late failure bin. In the RSS, the PWR7 source terms were based on a release associated with meltthrough of the basemat in scenarios with containment sprays operable. The late failure bin in the current study also includes overpressure failure cases with a direct release from the plant to the atmosphere. Of particular significance is the nontrivial release of iodine that is associated with late release mechanisms, which were not considered in the RSS.

Figure 10.3 compares release fractions for an aggregation of early drywell failure accident progression bins from the current study with the BWR2 and BWR3 release categories. In the current study, a range of reactor building decontamination factors is considered depending on the mode of drywell failure and variations in thermal-hydraulic conditions in the building. The BWR2 release fractions are at the upper bounds of the ranges in the current study, and the BWR3 releases are near the mean values.

The second example compares results for an isolation failure in the wetwell region from the RSS, release category BWR4, with the venting accident progression bin from the current study. The RSS results are very similar to the mean release terms for the venting bin, with the exception of the iodine group, which is higher because of the late release mechanisms (reevolution from the suppression pool and the reactor vessel) considered in the current study.

Overall, the comparison indicates that the source terms in the RSS were in some instances higher and in other instances lower than those in the current study. For the early containment failure accident progression bins that have the greatest impact on risk, however, the RSS source terms appear to be larger than the mean values of the current study and are typically at the upper bound of the uncertainty range.*

10.4 Perspectives

10.4.1 State of Methods

The use of parametric source term methods, in which the parameters are fit to reproduce the re-

sults of more mechanistic codes, was found to be a practical necessity in performing a PRA that includes a complete treatment of phenomenological uncertainties. Research is in progress in some of the key areas of uncertainty that influence source term results. In a number of cases, the STCP did not have models that represent potentially important phenomena, such as revaporization from reactor coolant system surfaces and reevolution of iodine from water pools. Later codes, such as MELCOR (Ref. 10.3), which have at least rudimentary models for these processes, should provide greater assurance of consistency in the analysis. These advanced codes may not, however, remove the need for parametric codes capable of performing a large number of analyses inexpensively.

Improvement in Understanding

Since the Reactor Safety Study (RSS), substantial improvements have been made in understanding severe accident processes and source term phenomena. A major shortcoming of the RSS was the limited treatment of the uncertainties in severe accident source terms. In the intervening years, particularly subsequent to the Three Mile Island accident, major experimental and code development efforts have broadly explored severe accident behavior. In this study, care has been taken to display the assessed uncertainties associated with the analysis of accident source terms. Many of the severe accident issues that are now recognized as the greatest sources of uncertainty were completely unknown to the RSS analysts 15 years ago.

10.4.2 Important Design Features

In Chapter 9, performance of the containments of the five plants was described with respect to the timing of the onset of containment failure and the magnitude of leakage to the environment. In particular, the likelihood of early containment failure was used as a measure of containment performance. Environmental source terms are affected by more than just the mode and timing of containment failure, however. The following paragraphs describe the effect of different safety systems and plant features on the magnitude of source terms.

Suppression Pools

Suppression pools can be very effective in the removal of radionuclides in the form of aerosols or

*Additional comparisons with the Reactor Safety Study may be found in Reference 10.9.

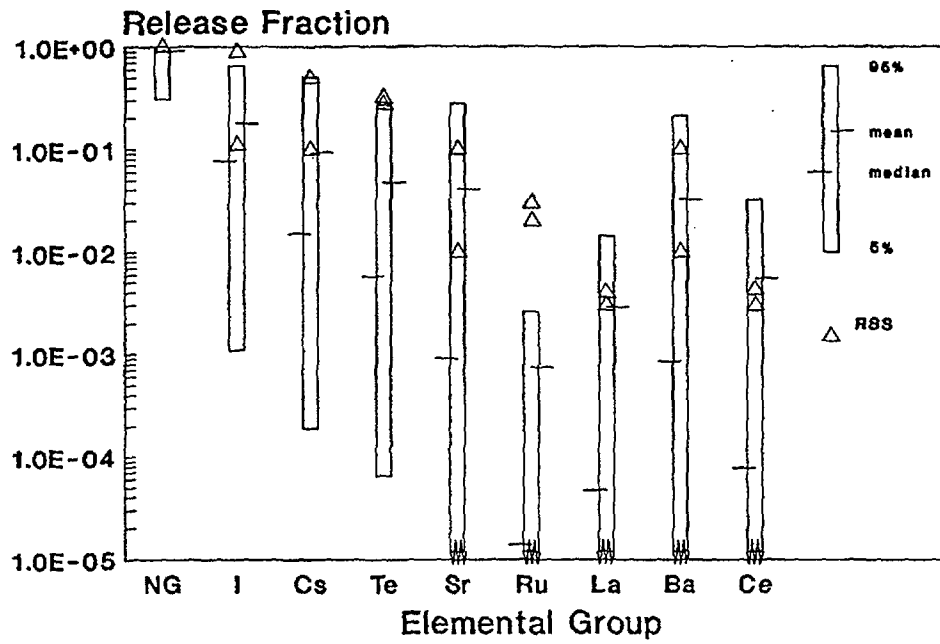

a. Comparison with Bins BWR2 and BWR3

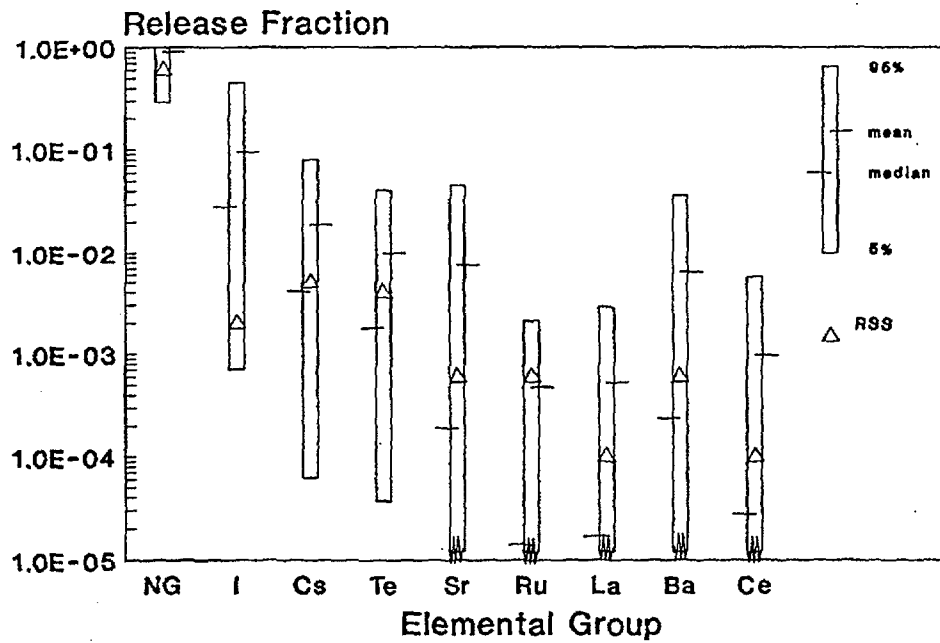

b. Comparison with Bin BWR4

Figure 10.3 Comparison of source terms with Reactor Safety Study (Peach Bottom).

10. Severe Accident Source Terms

soluble vapors. Some of the most important radionuclides, such as isotopes of iodine, cesium, and tellurium, are primarily released from fuel during the in-vessel release period. Because risk-dominant accident sequences in BWRs typically involve transient sequences rather than pipe breaks, the in-vessel release is directed to the suppression pool rather than being released to the drywell. As a result, the in-vessel release is subjected to scrubbing in the suppression pool, even if containment failure has already occurred. For the Peach Bottom plant, decontamination factors used in this study for scrubbing the in-vessel component ranged from approximately 1.2 to 4000, with a median value of 80. Since the early release of volatile radioactive material is typically the major contributor to early health effects, the effect of the suppression pool in depressing this component of the release is one of the reasons the likelihood of early fatalities is so low for the BWR designs analyzed.

Depending on the timing and location of containment failure, the suppression pool may also be effective in scrubbing the release occurring during core-concrete attack or reevolved from the reactor coolant system after vessel failure. In the Peach Bottom analyses, containment failure was found to be likely to occur in the drywell early in the accident. Thus, in many scenarios the suppression pool was not effective in mitigating the delayed release of radioactive material. Similarly, in the Grand Gulf design, drywell failure accompanied containment failure in approximately one-half the early containment failure scenarios analyzed. As a result, the suppression pool was found to be ineffective in mitigating ex-vessel releases in a substantial fraction of the scenarios for both BWR plants analyzed.

Although the decontamination factors for suppression pools are typically large, radioactive iodine captured in the pool will not necessarily remain there. Reevolution of iodine was found to be important in accident scenarios in which the containment has failed and the suppression pool is boiling.

Containment Sprays

If given adequate time, containment sprays can also be effective in reducing airborne concentrations of radioactive aerosols and vapors. In the Surry (subatmospheric) and Zion (large, dry) designs, approximately 20 percent of core meltdown sequences were predicted to eventually result in delayed failure or basemat meltthrough. The effect of sprays, in those scenarios in which they are

operational for an extended time, is to reduce the concentration of radioactive aerosols airborne in the containment to negligible levels in comparison with non-aerosol radionuclides (e.g., noble gases) with respect to potential radiological effects. For shorter periods of operation, sprays would be less effective but can still have a substantial mitigative effect on the release.

The Sequoyah (ice condenser) design has containment sprays for the purpose of condensing steam that might bypass the ice bed, as well as for use after the ice has melted. The effects of the sprays and ice beds in removing radioactive material are not completely independent since they both tend to remove larger aerosols preferentially.

In the Peach Bottom plant, drywell sprays can be operated in sequences in which ac power is available. Scrubbing of radioactive material released from fuel during core-concrete attack can be accomplished by a water layer developed on the drywell floor, as well as by the spray droplets. Containment spray operation in Grand Gulf is most important for scenarios in which both the containment and drywell have failed. In the short-term station blackout plant damage state, power recovery that is too late to arrest core damage can still be important for the operation of containment sprays and the mitigation of the extended period of ex-vessel release from fuel.

Ice Condenser

The ice beds in an ice condenser containment remove radioactive material from the air by processes that are very similar to those in the BWR pressure-suppression pools. The decontamination factor is very sensitive to the volume fraction of steam in the flowing gas, which in turn depends on whether the air-return fans are operational. For a typical case with the air-return fans on, the magnitude of the decontamination factors was assessed to be in the range from 1.2 to 20, with a median value of 3. Thus, the effectiveness of the ice bed in mitigating the release of radioactive material is likely to be substantially less than for a BWR suppression pool.

Drywell-Wetwell Configuration

The Mark III design has the apparent advantage, relative to the Mark I and Mark II designs, of the wetwell boundary completely enclosing the drywell, in effect providing a double barrier to radioactive material release. As long as the drywell remains intact, any release of radioactive material from the fuel would be subject to decontamination by the suppression pool. For this reason, failure

of the Mark III containment is not as important to severe accident risk as the potential for containment failure in combination with drywell failure. Figures 6.5 and 6.6 illustrate the difference in the environmental source terms for the early containment failure bins with and without drywell failure. With the drywell intact, the environmental source term is reduced to a level at which early fatalities would not be expected to occur, even for early failure of the outer containment. The potential advantages of the drywell-wetwell configuration were found to be limited in this study by the significant probability of drywell failure in an accident.

Cavity Flooding

The configuration of PWR reactor cavity or BWR pedestal regions affects the likelihood of water accumulation and water depth below the reactor vessel. The Surry reactor cavity is not connected by a flowpath to the containment floor. If the spray system is not operating, the cavity will be dry at vessel failure. In the Peach Bottom (Mark I) design, there is a maximum water depth of approximately 2 feet on the pedestal and drywell floor before water would overflow into the downcomer. The other three designs investigated have substantially greater potential for water accumulation in the pedestal or cavity region. In the Sequoyah design, the water depth could be as much as 40 feet.

If a coolable debris bed is formed in the cavity or pedestal and makeup water is continuously supplied, core-concrete release of radioactive material would be avoided. Even if molten core-concrete interaction occurs, a continuous overlaying pool of water can substantially reduce the release of radioactive material to the containment.

Reactor Building/Auxiliary Building Retention

Radionuclide retention was evaluated for the Peach Bottom reactor building, but an evaluation was not made for the portion of the reactor building that surrounds the Grand Gulf containment, which was assessed to have little potential for retention. The range of decontamination factors for aerosols for the Peach Bottom reactor building subsequent to drywell rupture was 1.1 to 80 with a median value of 2.6. The location of drywell failure affects the potential for reactor building decontamination. Leakage past the drywell head to the refueling building was assumed to result in very little decontamination. Failure of the drywell by meltthrough resulted in a release that was sub-

jected to a decontamination factor of 1.3 to 90 with a median value of 4.

In the interfacing LOCA sequences in the PWRs, some retention of radionuclides was assumed in the auxiliary building (in addition to water pool decontamination for submerged releases). In the Sequoyah analyses, retention was enhanced by the actuation of the fire spray system.

Containment Venting

In the Peach Bottom (Mark I) and Grand Gulf (Mark III) designs, procedures have been implemented to intentionally vent the containment to avoid overpressure failure. By venting from the wetwell air space (in Peach Bottom) and from the containment (in Grand Gulf), assurance is provided that, subsequent to core damage, the release of radionuclides through the vent line will have been subjected to decontamination by the suppression pool.

As discussed in Chapter 8, containment venting to the outside can substantially improve the likelihood of recovery from a loss of decay heat removal plant damage state and, as a result, reduce the frequency of severe accidents. The results of this study indicate, however, only limited benefits in consequence mitigation for the existing procedures and hardware for venting. Uncertainties in the decontamination factor for the suppression pool and for the ex-vessel release and in the reevolution of iodine from the suppression pool are quite broad. As a result, the consequences of a vented release are not necessarily minor. Furthermore, the effectiveness of venting in the two plant designs is limited by the high likelihood of mechanisms leading to early containment failure, which would result in bypass of the vent.

10.4.3 Important Phenomenological Uncertainties

In order to identify the principal sources of uncertainties in the estimated risk, regression analyses were performed for each of the plant types in this study. In general, in these regression analyses, the dependent variable is risk expressed in terms of consequences per year (e.g., early fatalities per year or latent cancer fatalities per year). For the Surry plant (Ref. 10.10), however, additional regression analyses were performed in which the dependent variable is the quantity of release per year for each of the radionuclide groups. These analyses are particularly useful in investigating how uncertainties in source term variables affect the releases of different radionuclides. Also determined were partial correlation coefficients that represent

10. Severe Accident Source Terms

the importance of uncertain variables as a function of the magnitude of the environmental release.

Relative Importance of Source Term Variables

The results of these regression analyses indicate that uncertainties in source term variables are important contributors to the uncertainties in risk but are often not the largest contributors. The relative contribution of uncertainties in source term variables depends on the characteristics of each plant damage state as illustrated in the Peach Bottom and Sequoyah regression analyses (Refs. 10.11 and 10.12). In general, the five plant analyses indicate that the importance of the aggregate of variables that affect release frequencies (accident frequency variables and accident progression variables) is similar to or greater than the importance of the aggregate of variables that affect source term magnitude.

Source term variables tend to have less importance to the uncertainty in latent cancer fatality (or population dose) risk than to the risk of early fatalities. Because of the threshold nature of early fatalities, these risk results are particularly sensitive to pessimistic values of source term variables.

Importance of Source Term Variables to Uncertainty in Environmental Release

Based on analyses performed for the Surry plant (Ref. 10.10), the importance of source term variables is seen to be different for different groups of radionuclides. The uncertainty in the release of noble gases is dominated by the uncertainty in accident frequency variables. The relative uncertainties in release fractions for the noble gases and in retention mechanisms (only volumetric holdup is assumed) are small.

The character of the risk-dominant accident sequences at Surry plays an important role in determining the importance of the source term variables for the other radionuclide groups. The steam generator tube rupture (SGTR) accident and the interfacing-system LOCA sequences (the risk-dominant sequences) involve bypass routes in which radionuclides released from the core transport to the environment without being subjected to containment deposition processes. As a result, steam generator retention and the release of radionuclides from the fuel during in-vessel melt progression are the largest contributors to uncertainty for the volatile radionuclides, iodine and cesium, and for the semivolatile radionuclides, tel-

lurium, barium, strontium, and ruthenium. For the involatile radionuclides, lanthanum and cerium, the release of radionuclides during core-concrete interactions is also an important contributor.

The Surry analyses also indicate that the uncertainties in source term variables tend to have relatively more importance for large releases. For small releases of radionuclides, the uncertainties are dominated by the uncertainties associated with the accident frequencies.

Plant-Specific Importance of Source Term Variables to Uncertainty in Risk

Consistent with the discussion in the previous section, the largest contributors to uncertainty in early fatality risk for the Surry plant (Ref. 10.10) are the frequency of the interfacing-system LOCA sequence and two source term variables, retention in the steam generator (in an SGTR accident) and release from the fuel during in-vessel melt progression. For latent cancer fatality risk, the frequency of SGTR accidents becomes of higher importance and the frequency of interfacing-system LOCAs of reduced importance. Steam generator retention and in-vessel release of radionuclides are of comparable importance to the accident frequency variables.

The Zion results (Ref. 10.13) are similar to those for Surry but reflect a reduced significance of the interfacing-system LOCA sequence and an increased importance of steam explosions as a mode of early containment failure (this results from a much lower frequency of interfacing-system LOCA in Zion). Release of radionuclides from fuel in-vessel, steam generator retention (in an SGTR accident), and containment retention of material released prior to vessel breach (as applied in a steam explosion scenario) are the most important source term contributors to the uncertainty in early fatality risk. For latent cancer fatality risk, containment failure from a steam explosion is of reduced significance and, as a result, containment retention is not an important contributor to risk uncertainty.

For early fatality risk at Sequoyah (Ref. 10.12), the frequency of the interfacing-system LOCA is the most important contributor to uncertainty. Containment failure by overpressurization is a more likely early failure mechanism for Sequoyah than for the large, high-pressure containments at Zion and Surry. As a result, accident progression mechanisms such as pressure rise at vessel breach and containment failure pressure are also important contributors to risk uncertainty for the

Sequoyah design. The most significant source term variables are in-vessel retention fraction, containment retention fraction for the in-vessel release, and steam generator deposition (in an SGTR accident). For latent cancer fatality risk, the frequency of the SGTR accident is the most important contributor to uncertainty; none of the source term variables is significant.

Regression results were obtained for internal initiators, fire events, and seismic events for the Peach Bottom plant (Ref. 10.11). For early fatality risk from internal initiators, release from fuel in-vessel, release during core-concrete interactions, and fractional release from containment of the core-concrete source terms are the most important contributors to uncertainty. The containment building decontamination factor, late release of iodine, reactor coolant system retention, and revaporization also contribute at a level similar to the contribution from the frequencies of the acci-

dent sequences. For fire initiators, the contributions from the various source term variables are similar but slightly reduced consistent with greater uncertainty in the initiator frequency.

For latent cancer fatality risk at Peach Bottom, the important source term variables are the same as for the early fatality risk but are relatively less important than the contribution from uncertainties in the accident frequencies.

In the Grand Gulf analyses (Ref. 10.14), the source term variables were indicated to be less important than the accident sequence and accident progression variables. The most significant source term variable was indicated to be the release fraction from containment following vessel failure. The decontamination factor for the suppression pool, spray decontamination factor, in-vessel release of radioactive material, and in-vessel retention of radioactive material were also identified as moderate contributors to the uncertainty in risk.

REFERENCES FOR CHAPTER 10

- 10.1 M. Silberberg et al., "Reassessment of the Technical Bases for Estimating Source Terms," U.S. Nuclear Regulatory Commission (USNRC) Report NUREG-0956, July 1986.
- 10.2 J. A. Gieseke et al., "Source Term Code Package, A User's Guide (Mod. 1)," Battelle Columbus Division, NUREG/CR-4587, BMI-2138, July 1986.
- 10.3 R. M. Summers et al., "MELCOR In-Vessel Modeling," *Proceedings of the Fifteenth Water Reactor Safety Information Meeting* (Gaithersburg, MD), NUREG/CP-0091, February 1988.
- 10.4 Fauske and Associates, Inc., "MAAP Modular Accident Analysis Program User's Manual," Vols. I and II, IDCOR Technical Report 16.2-3, February 1987.
- 10.5 K. D. Bergeron et al., "User's Manual for CONTAIN 1.0, A Computer Code for Severe Reactor Accident Containment Analysis," Sandia National Laboratories, NUREG/CR-4085, SAND84-1204, July 1985.
- 10.6 D. I. Chanin, H. Jow, J. A. Rollstin et al., "MELCOR Accident Consequence Code System (MACCS)," Sandia National Laboratories, NUREG/CR-4691, Vols. 1-3, SAND86-1562, February 1990.
- 10.7 USNRC, "Reactor Safety Study—An Assessment of Accident Risks in U. S. Commercial Nuclear Power Plants," WASH-1400 (NUREG-75/014), October 1975.
- 10.8 G. D. Kaiser, "The Implications of Reduced Source Terms for Ex-Plant Consequence Modeling," Executive Conference on the Ramifications of the Source Term (Charleston, SC), March 12, 1985.
- 10.9 L. LeSage et al., "Report of the Special Committee on NUREG-1150, The NRC's Study of Severe Accident Risks," American Nuclear Society, June 1990.
- 10.10 R. J. Breeding et al., "Evaluation of Severe Accident Risks: Surry Unit 1," Sandia National Laboratories, NUREG/CR-4551, Vol. 3, Revision 1, SAND86-1309, October 1990.
- 10.11 A. C. Payne, Jr., et al., "Evaluation of Severe Accident Risks: Peach Bottom Unit 2," Sandia National Laboratories, NUREG/CR-4551, Vol. 4, Draft Revision 1, SAND86-1309, to be published.*
- 10.12 J. J. Gregory et al., "Evaluation of Severe Accident Risks: Sequoyah Unit 1," Sandia National Laboratories, NUREG/CR-4551, Vol. 5, Revision 1, SAND86-1309, December 1990.
- 10.13 C. K. Park et al., "Evaluation of Severe Accident Risks: Zion Unit 1," Brookhaven National Laboratory, NUREG/CR-4551, Vol. 7, Draft Revision 1, BNL-NUREG-52029, to be published.*
- 10.14 T. D. Brown et al., "Evaluation of Severe Accident Risks: Grand Gulf Unit 1," Sandia National Laboratories, NUREG/CR-4551, Vol. 6, Draft Revision 1, SAND86-1309, to be published.*

*Available in the NRC Public Document Room, 2120 L Street NW., Washington, DC.

11. PERSPECTIVES ON OFFSITE CONSEQUENCES

11.1 Introduction

Frequency distributions, in the form of complementary cumulative distribution functions (CCDFs), of four selected offsite consequence measures of the atmospheric releases of radionuclides in reactor accidents (with all source terms contributing) have been presented in Chapters 3 through 7 for the five plants* covered in this study. For each consequence measure, the 5th percentile, 50th percentile (median), 95th percentile, and the mean CCDFs were shown. This chapter provides some perspectives on the offsite consequence results for these plants.

Section 11.2 provides a discussion on the basis of the CCDFs. Section 11.3 discusses, summarizes, and compares the consequence results for the five plants displayed in the mean and the median CCDFs. Section 11.4 compares the results from the mean and median CCDFs with those of the Reactor Safety Study (Ref. 11.1). Sections 11.5 and 11.6, respectively, provide discussions on potential sources of uncertainty in consequence analysis and on sensitivities of the mean CCDFs to the assumptions on the offsite protective measures to mitigate the consequences.

Some of the perspectives provided in this chapter relate to the effectiveness of various methods of offsite emergency response. For these five plants, it appears that evacuation is the most effective emergency response for the risk-dominant accident sequences. However, as discussed below, the calculated effectiveness of a response is sensitive to assumptions on the timing of warnings to people offsite before radioactive release, the estimated delay before evacuation and the effective speed of evacuating populations, and the energy of the release. In this chapter, the results of sensitivity studies on some of these factors are discussed. The reader should not infer that these results signal a modification to NRC's emergency response guidance. Rather, they provide a glimpse of the type of technical assessment that would be required in NRC's reevaluation of emergency response.

11.2 Discussion of Consequence CCDFs

As discussed in the earlier chapters, a large number of source terms, each with its own frequency,

*See Figures 3.9, 3.10; 4.9, 4.10; 5.8; 6.8; and 7.7, respectively, for Surry, Peach Bottom, Sequoyah, Grand Gulf, and Zion.

were initially developed for each of the five plants. They spanned a wide spectrum of plant damage states, phenomenological scenarios, and source term uncertainties for each plant that led to radionuclide releases to the atmosphere. However, for the purpose of the manageability of the offsite consequence analysis, such large numbers of source terms for each plant were reduced to a much smaller number (about 30 to 60) of representative source term groups.

Each source term group was treated as a single source term in the offsite consequence analysis code, MACCS (Ref. 11.2). The MACCS analyses incorporated the mitigating effects of the offsite protective actions. The magnitudes of the selected consequence measures and their meteorology-based probabilities were calculated by MACCS for each source term group and were used to generate the meteorology-based CCDFs. These conditional CCDFs of the consequence measures for all individual source term groups served as the basic data set for further analysis. When the conditional CCDFs of a consequence measure were weighted by the frequencies of the source term groups, the 5th percentile, 50th percentile (median), 95th percentile, and the mean values of the frequencies at various magnitude levels of the consequence measure were obtained and displayed as CCDFs in Chapters 3 through 7.

Thus, in this procedure, both the frequencies of the source term groups and the probabilities of the site meteorology (which in combination with the source term groups lead to the various consequence magnitude levels) have been used in generating the percentile and mean CCDFs. (The construction of these CCDFs is discussed in Section A.9 of Appendix A.)

11.3 Discussion, Summary, and Interplant Comparison of Offsite Consequence Results

The various percentile and the mean CCDFs of the consequence measures shown in Chapters 3 through 7 display the uncertainties in the offsite consequences stemming from the in-plant uncertainties up to the source terms and their frequencies and the ex-plant uncertainties due to the variability of the site meteorology. The 5th and 95th percentile CCDFs provide a reasonable display of the bounds of the offsite consequences frequency distributions for the five plants.

11. Offsite Consequences

Tables 11.1 and 11.2 present the information contained in the mean and the median CCDFs in tabular form. Entries in these tables are the exceedance frequency levels of 10^{-5} , 10^{-6} , 10^{-7} , 10^{-8} , and 10^{-9} per reactor year and the magnitudes of the consequences that will be exceeded at these frequencies for the five plants.

As stated in Chapters 3 through 7, the CCDFs of the consequence measures presented in those chapters (and, therefore, the results shown in Tables 11.1 and 11.2) incorporate the benefits of evacuation of 99.5 percent of the population within the 10-mile plume exposure pathway emergency planning zone (EPZ), early relocation of the remaining population from the heavily contaminated areas both within and outside the 10-mile EPZ, and other protective measures. Details of the assumptions on the protective measures are presented in Table 11.3.

The results shown in Tables 11.1 and 11.2 for the five plants are discussed below.

Early Fatality Magnitudes

The early fatality magnitudes (persons) at various exceedance frequencies for a plant are driven by the core damage frequency and the radionuclide release parameters of the source term groups for the plant; the site meteorology and the population distribution in the close-in site region; and the effectiveness of the emergency response. These factors are different for the five plants. Therefore, different values of early fatality magnitudes are shown for equal levels of exceedance frequencies.

Some of the plant/site features contributing to the differences between the early fatality CCDFs of the five plants are discussed below:

- Core damage frequencies for the internal initiators for Peach Bottom and Grand Gulf are lower than those for the other three plants. Therefore, the early fatality CCDFs for Peach Bottom and Grand Gulf are associated with relatively low exceedance frequencies.
- Quantities of radionuclides associated with the early phase of the release* in the source term

*Virtually all source term groups developed for this study have two release phases—an early release phase and a later release phase. Early fatalities are essentially due to the early release. This is because the wind direction may change before the later release, so that the later release would not always add to the radiation dose of the same people who were affected by the early release, and evacuation or relocation would likely be completed before the later release would occur.

groups for Peach Bottom and Grand Gulf are typically smaller than those for the other three plants because of suppression pool scrubbing. This lowered the early fatality magnitudes for these two plants.

- Several source term groups for Surry and Sequoyah with large quantities of radionuclides associated with the early release phase are also associated with large thermal energy in this phase. This resulted in vertical rise of the plume in several meteorological scenarios, reducing the potential for large early fatality magnitudes.
- The time of warning before the start of the radionuclide release strongly influences the effectiveness of the emergency response, particularly the evacuation. The source term groups for Peach Bottom and Grand Gulf with potential for early fatalities, unless mitigated by emergency response, are also associated with warning times that are well in advance of the release compared to those for the other three plants because the most important accident sequences for the BWRs develop more slowly than those for the PWRs of this study. In contrast, warning times are close to the start of the release (about 40 minutes before the release) for the source term groups containing the fast-developing interfacing-system LOCA accident sequences for Surry and Sequoyah, which also have large quantities of radionuclides in the release.
- The Zion site has the highest population density within the 10-mile EPZ among the five plants (although about half of the area in this zone for Zion is water). It is followed by Surry, Sequoyah, Peach Bottom, and Grand Gulf.
- For Zion, Surry, and Sequoyah, relatively long evacuation delay times after the warnings and slow effective evacuation speeds were calculated. For Peach Bottom and Grand Gulf, relatively short evacuation delay times and fast effective evacuation speeds were calculated. Values of these parameters were based on the utility-sponsored plant-specific studies and the NRC requirements for emergency planning. The utility-sponsored evacuation time estimate studies, however, were not evaluated in terms of how well they realistically represent the sites.

In the MACCS calculations, early warnings before the radionuclide release and short evacuation

Table 11.1 Summaries of mean and median CCDFs of offsite consequences—fatalities.

| Exceedance Frequency (ry ⁻¹) | Early Fatalities (persons) ^a | | | | | | | Latent Cancer Fatalities (persons) ^a | | | | | | |
|--|---|------|------|----|------|------|------|---|------|-------------------|------|------|------|------|
| | 1* | 2* | 3* | 4* | 5* | 6* | 7* | 1* | 2* | 3* | 4* | 5* | 6* | 7* |
| 10 ⁻⁵ | | | | | | | | | | | | | | |
| Int. ^b | 0 | 0 | 0 | 0 | 0 | - | - | 0 | 0 | 6(1) ^c | 0 | 0 | - | - |
| Fire | 0 | 0 | 0 | 0 | 0 | 0 | 0 | 0 | 0 | 2(1) | 0 | 0 | 7(2) | 1(3) |
| | 0 | 0 | - | - | - | - | - | 0 | 6(2) | - | - | - | - | - |
| | 0 | 0 | - | - | - | - | - | 0 | 0 | - | - | - | - | - |
| 10 ⁻⁶ | | | | | | | | | | | | | | |
| Int. | 0 | 0 | 0 | 0 | 0 | - | - | 1(3) | 1(3) | 4(3) | 3(2) | 8(3) | - | - |
| Fire | 0 | 0 | 0 | 0 | 0 | 0 | 0 | 4(2) | 2(2) | 1(3) | 0 | 2(3) | 5(3) | 5(3) |
| | 0 | 0 | - | - | - | - | - | 1(1) | 8(3) | - | - | - | - | - |
| | 0 | 0 | - | - | - | - | - | 7(0) | 3(3) | - | - | - | - | - |
| 10 ⁻⁷ | | | | | | | | | | | | | | |
| Int. | 3(0) | 0 | 5(1) | 0 | 2(2) | - | - | 8(3) | 8(3) | 9(3) | 1(3) | 3(4) | - | - |
| Fire | 0 | 0 | 2(0) | 0 | 2(0) | 2(2) | 2(0) | 4(3) | 3(3) | 6(3) | 6(2) | 1(4) | 2(4) | 2(4) |
| | 0 | 0 | - | - | - | - | - | 4(2) | 2(4) | - | - | - | - | - |
| | 0 | 0 | - | - | - | - | - | 2(1) | 1(4) | - | - | - | - | - |
| 10 ⁻⁸ | | | | | | | | | | | | | | |
| Int. | 4(1) | 0 | 4(2) | 0 | 3(3) | - | - | 2(4) | 2(4) | 2(4) | 3(3) | 8(4) | - | - |
| Fire | 0 | 0 | 5(1) | 0 | 5(1) | 1(3) | 3(2) | 9(3) | 1(4) | 1(4) | 2(3) | 2(4) | 3(4) | 3(4) |
| | 0 | 1(0) | - | - | - | - | - | 5(3) | 4(4) | - | - | - | - | - |
| | 0 | 0 | - | - | - | - | - | 6(1) | 2(4) | - | - | - | - | - |
| 10 ⁻⁹ | | | | | | | | | | | | | | |
| Int. | 1(2) | 1(0) | 2(3) | 0 | 4(3) | - | - | 4(4) | 4(4) | 2(4) | 6(3) | 1(5) | - | - |
| Fire | 8(0) | 0 | 2(2) | 0 | 8(2) | 4(3) | 2(3) | 2(4) | 2(4) | 2(4) | 3(3) | 4(4) | 4(4) | 5(4) |
| | 1(1) | 3(0) | - | - | - | - | - | 2(4) | 5(4) | - | - | - | - | - |
| | 0 | 0 | - | - | - | - | - | 1(3) | 4(4) | - | - | - | - | - |

* Plant Names: 1 = Surry; 2 = Peach Bottom; 3 = Sequoyah; 4 = Grand Gulf; 5 = Zion; 6 = RSS-PWR; 7 = RSS-BWR

a. First line of entries corresponds to mean CCDF; second line corresponds to median CCDF.

b. Int. = Internal initiating events

c. 6(1) = 6 X 10¹ = 60

Table 11.2 Summaries of mean and median CCDFs of offsite consequences—population exposures.

| Exceedance Frequency (ry ⁻¹) | 50-Mile Region Population Exposure (person-rem) ^a | | | | | Entire Site Region Population Exposure (person-rem) ^a | | | | |
|--|--|------|------|------|------|--|------|------|------|------|
| | 1* | 2* | 3* | 4* | 5* | 1* | 2* | 3* | 4* | 5* |
| 10 ⁻⁵ | | | | | | | | | | |
| Int. ^b | 7(2) ^c | 0 | 1(5) | 0 | 5(3) | 2(3) | 0 | 4(5) | 0 | 9(3) |
| | 2(2) | 0 | 4(4) | 0 | 3(3) | 3(2) | 0 | 1(5) | 0 | 4(3) |
| Fire | 5(1) | 1(6) | - | - | - | 1(2) | 3(6) | - | - | - |
| | 0 | 2(3) | - | - | - | 0 | 3(3) | - | - | - |
| 10 ⁻⁶ | | | | | | | | | | |
| Int. | 1(6) | 3(6) | 3(6) | 2(5) | 2(7) | 8(6) | 7(6) | 2(7) | 2(6) | 5(7) |
| | 6(5) | 6(5) | 1(6) | 1(2) | 3(6) | 2(6) | 1(6) | 7(6) | 2(2) | 1(7) |
| Fire | 3(4) | 1(7) | - | - | - | 1(5) | 5(7) | - | - | - |
| | 2(4) | 6(6) | - | - | - | 6(4) | 2(7) | - | - | - |
| 10 ⁻⁷ | | | | | | | | | | |
| Int. | 8(6) | 1(7) | 8(6) | 6(5) | 8(7) | 5(7) | 5(7) | 6(7) | 9(6) | 2(8) |
| | 5(6) | 6(6) | 4(6) | 3(5) | 3(7) | 2(7) | 2(7) | 3(7) | 3(6) | 7(7) |
| Fire | 6(5) | 3(7) | - | - | - | 2(6) | 1(8) | - | - | - |
| | 1(5) | 1(7) | - | - | - | 2(5) | 7(7) | - | - | - |
| 10 ⁻⁸ | | | | | | | | | | |
| Int. | 2(7) | 2(7) | 2(7) | 1(6) | 2(8) | 1(8) | 1(8) | 9(7) | 2(7) | 3(8) |
| | 9(6) | 1(7) | 7(6) | 6(5) | 7(7) | 6(7) | 8(7) | 6(7) | 9(6) | 1(8) |
| Fire | 6(6) | 5(7) | - | - | - | 3(7) | 2(8) | - | - | - |
| | 5(5) | 3(7) | - | - | - | 6(5) | 1(8) | - | - | - |
| 10 ⁻⁹ | | | | | | | | | | |
| Int. | 3(7) | 4(7) | 4(7) | 2(6) | 4(8) | 2(8) | 2(8) | 1(8) | 3(7) | 4(8) |
| | 1(7) | 2(7) | 1(7) | 1(6) | 1(8) | 1(8) | 1(8) | 1(8) | 2(7) | 2(8) |
| Fire | 2(7) | 6(7) | - | - | - | 9(7) | 3(8) | - | - | - |
| | 1(6) | 4(7) | - | - | - | 8(6) | 2(8) | - | - | - |

*Plant Names: 1 = Surry; 2 = Peach Bottom; 3 = Sequoyah; 4 = Grand Gulf; 5 = Zion
a. First line of entries corresponds to mean CCDF; second line corresponds to median CCDF.
b. Int. = Internal initiating events
c. 7(2) = 7 X 10² = 700

Table 11.3 Offsite protective measures assumptions.

1. Emergency Response Assumptions

- a. Within 10-mile plume exposure pathway emergency planning zone (EPZ):

Evacuation of people after a delay* following the warning given by the reactor operator on the imminent radionuclide release.

Average evacuation delay times (hr): Surry 2.0, Peach Bottom 1.5, Sequoyah 2.3, Grand Gulf 1.25, Zion 2.3.

Average effective radial evacuation speeds (mile/hr): Surry 4.0, Peach Bottom 10.7, Sequoyah 3.1, Grand Gulf 8.3, Zion 2.5.

- b. Outside of 10-mile EPZ:

Early relocation of people: within 12 hours/24 hours after plume passage from areas where the projected lifetime effective whole body dose equivalent (EDE), as defined in ICRP Publications 26 and 30, from a 7-day occupancy would exceed 50 rems/25 rems.

Note: These assumptions are also extended inward up to the plant site boundary for the nonevacuating or nonsheltering people.

2. Protective Action Guides (PAGs) for Long-Term Countermeasures

- a. FDA "emergency" PAG for directly contaminated foods and animal feeds—dose not to exceed 5-rem EDE and 15-rem thyroid (Ref. 11.3).

- b. EPA's proposed PAGs for continuation of living in contaminated environment—dose not to exceed:

- 2-rem EDE in the first year

- 0.5-rem EDE in the second year

from groundshine and inhalation of resuspended radionuclides.

Note: EPA's criteria (Ref. 11.4) are approximated in MACCS as dose not to exceed 4-rem EDE in 5 years.

- c. In absence of any Federal agency criteria for ingestion dose to an individual from foods grown on contaminated soil via root uptake, MACCS assumes a PAG of 0.5-rem EDE and 1.5-rem thyroid for this pathway, which is similar to FDA's "preventive" PAG for directly contaminated food and animal feeds (Ref. 11.3).

*Time steps involved during the delay are: (1) notification of the offsite authorities, (2) evaluation and decision by the authorities, (3) public notification advising evacuation, and (4) people's preparation for evacuation.

11. Offsite Consequences

delay times for Peach Bottom and Grand Gulf enabled the evacuees to have a substantial head start on the plume. This, coupled with relatively fast effective evacuation speeds, enabled the evacuees to almost always avoid the trailing radioactive plumes. Thus, the relatively lower core damage frequencies, lower magnitudes of source term groups in the early phase of release, early warnings, lower population densities, lower evacuation delays, and higher evacuation speeds made the Peach Bottom and Grand Gulf early fatality CCDFs in Figures 4.9 and 6.8 lie in the low frequency and low magnitude regions, and early fatality magnitude entries in Table 11.1 small or nil.

Surry and Sequoyah fit between Peach Bottom/Grand Gulf and Zion. For Surry and Sequoyah, warnings close to release in the interfacing-system LOCA accident sequences made evacuation less effective for these sequences. Also, evacuation was less effective in the plume rise scenarios for those source terms for which early release phases were associated with large quantities of radionuclides and large amounts of thermal energy (sequences with early containment failure at vessel breach). With the plume rise, the highest air and ground radionuclide concentrations occur at some distance farther from the reactor (instead of occurring close to the reactor without plume rise). In such cases, the late starting evacuees from the close-in regions moving away from the reactor in the downwind direction encounter higher concentrations and receive higher doses.

Latent Cancer Fatality Magnitudes

The estimates of latent cancer fatality magnitude at various exceedance frequencies include the benefits of the protective measures discussed above. Contributions from radiation doses down to very low levels have been included. If future research concludes that it is appropriate to truncate the individual dose at a *de minimis* level, reduced latent cancer fatality estimates would be obtained.

Variations of the latent cancer fatality magnitude for the five plants at equal exceedance frequency levels primarily arise because of differences in the source term groups and their frequencies, site meteorologies, and differences in the site demography, topography, land use, agricultural practice and productivity, and distribution of fresh water bodies up to 50 to 100 miles from the plants.

Emergency response in the close-in regions has only a limited beneficial impact on delayed cancer

fatality magnitude and does not contribute substantially to the differences in the cancer fatality CCDFs for the five plants. The long-term protective measures, such as temporary interdiction, condemnation, and decontamination of land, property, and foods contaminated above acceptable levels are based on the same protective action guides (PAGs) for all plants. Further, the site differences for the five plants are not large enough beyond the distances of 50 to 100 miles to contribute substantially to the differences in the latent cancer fatality CCDFs.

Population Exposure Magnitudes

Population exposure magnitudes (person-rem*) at various exceedance frequencies include the contributions from the early and chronic exposures. These magnitudes reflect the dose-saving actions of the protective measures and, therefore, are the residual magnitudes.

Variations of the population exposure magnitudes for the five plants at equal exceedance frequency levels were similar to those of the cancer fatality magnitudes discussed earlier.

The relative contributions of the exposure pathways to the population dose for a given plant are highly source term dependent. Examples of relative contributions of early and chronic exposure pathways (see Chapter 2 and Appendix A) to the meteorology-averaged mean estimates of the 50-mile and entire region population dose for selected source term groups for the five plants are shown in Table 11.4. For brevity of presentation, only four source term groups that are the top contributors to the risks of the population dose for the five plants are selected. These source term groups are designated only by their identification numbers in Table 11.4. The chronic exposure pathway is shown subdivided in terms of direct (groundshine and inhalation of resuspended radionuclides) and ingestion (food and drinking water) pathways.

For a qualitative understanding of the results shown in Table 11.4, it should be noted that:

- All radionuclides contribute to the early exposure pathway; all nonnoble gas radionuclides contribute to the chronic direct exposure pathway; and only the radionuclides of iodine, strontium, and cesium contribute to the chronic ingestion exposure pathway.

*Effective dose equivalent (EDE) (as defined in ICRP Publications 26 and 30) in the unit of rem is used in the definition of person-rem.

Table 11.4 Exposure pathways relative contributions (percent) to meteorology-averaged conditional mean estimates of population dose for selected source term groups.

| Plant Name | Source Term Group Identification Number | 50-Mile Region* | | | Entire Region* | | |
|--------------|---|-----------------|----------------|-------------------|----------------|----------------|-------------------|
| | | Early Exposure | Chronic Direct | Chronic Ingestion | Early Exposure | Chronic Direct | Chronic Ingestion |
| Surry | 9 | 28 | 68 | 2 | 10 | 69 | 20 |
| | 33 | 51 | 41 | 3 | 14 | 74 | 12 |
| | 37 | 33 | 58 | 5 | 9 | 79 | 12 |
| | 49 | 13 | 80 | 7 | 9 | 58 | 33 |
| Peach Bottom | 28 | 28 | 66 | 2 | 15 | 77 | 7 |
| | 34 | 42 | 47 | 5 | 24 | 68 | 5 |
| | 37 | 38 | 52 | 5 | 20 | 72 | 6 |
| | 40 | 23 | 70 | 3 | 10 | 81 | 8 |
| Sequoyah | 32 | 49 | 36 | 8 | 11 | 68 | 20 |
| | 35 | 42 | 47 | 6 | 8 | 59 | 32 |
| | 43 | 49 | 28 | 19 | 11 | 73 | 15 |
| | 44 | 59 | 29 | 9 | 12 | 75 | 13 |
| Grand Gulf | 19 | 24 | 62 | 12 | 17 | 46 | 42 |
| | 25 | 16 | 65 | 16 | 4 | 54 | 41 |
| | 28 | 10 | 72 | 16 | 3 | 41 | 57 |
| | 32 | 41 | 39 | 17 | 12 | 62 | 25 |
| Zion | 139 | 50 | 46 | 1 | 27 | 56 | 16 |
| | 175 | 71 | 21 | 2 | 49 | 39 | 8 |
| | 142 | 24 | 73 | 1 | 23 | 60 | 15 |
| | 136 | 44 | 49 | 2 | 12 | 67 | 20 |

*The difference between 100 percent and the sum of the pathway contributions is the relative population dose to the decontamination workers.

11. Offsite Consequences

- Early exposure pathway population dose estimated is largely unmitigated, except for the evacuated and relocated people. In addition to cloudshine and cloud inhalation during plume passage, it includes the groundshine and inhalation of resuspended radionuclides for a period of 7 days after the radionuclide release.
- Chronic exposure pathway involves dose integration from 7 days to all future times (i.e., the sum total of the dose over time).
- In the MACCS analysis, the protective actions to mitigate the chronic exposure pathways are largely confined to the 50-mile region of the site. Outside the 50-mile region, the mitigative actions (based on the PAGs) are generally not triggered in MACCS because of the relatively low levels of contamination (however, sometimes they are triggered depending on the meteorology and the source term magnitudes).
- Protective actions are not assumed for water ingestion.

Except for Grand Gulf, Table 11.4 shows that in the 50-mile region the early exposure pathway population dose and the chronic direct exposure pathway population dose are roughly similar; the chronic ingestion pathway makes smaller contributions. For the entire region, the chronic direct exposure pathway has increased contributions relative to the early exposure pathway. This is because at longer distances the early exposure pathway has weakened as a result of low air and ground concentrations and the short (i.e., 7 days) integration time for ground exposure. Relative contributions of the chronic ingestion exposure pathway are also higher for the entire region. This is because the chronic direct exposure is dependent on population size and the chronic ingestion exposure is dependent on farmland and water body surface area. An increase in the population size with distance from a plant generally occurs less rapidly compared to the increase in the area with distance.

For Grand Gulf, generally the contributions from the early exposure pathway are lower than the chronic direct exposure pathway in the 50-mile region relative to the other four plants and are due to the characteristics of the selected source term groups. For the entire region, the relative contributions of the early exposure pathway and chronic direct exposure pathway are similar to the other plants. However, the ingestion exposure

pathway has higher contributions both in the 50-mile and entire region compared to the other plants. This is because the Grand Gulf site region has a smaller population size and a larger area devoted to farming than the other four sites of this study.

11.4 Comparison with Reactor Safety Study

The mean and the median CCDFs of two of the selected consequence measures, namely, early fatalities and latent cancer fatalities, displayed in Chapters 3 through 7 for the internal initiators of the reactor accidents and summarized in Table 11.1, may be compared with the CCDFs displayed in the Reactor Safety Study (RSS). However, the RSS CCDFs are the results of superpositions of the meteorology-based conditional CCDFs for the RSS "release categories"* after being weighted by the median frequencies of the release categories. The CCDFs shown in Chapters 3 through 7 are calculated in a different way from the RSS CCDFs. Thus, they are not strictly comparable.

The RSS CCDFs of early fatalities and latent cancer fatalities are shown in the RSS Figures 5-3 and 5-5, respectively. The magnitudes of delayed cancer fatalities shown in the RSS CCDFs are actually the magnitudes of their projected uniform annual rates of occurrence over a 30-year period. Thus, these RSS rate magnitudes need to be multiplied by a factor of 30 to derive their total magnitudes. After performing this step, the RSS results have been entered in Table 11.1 for comparison with the results of this study.

Table 11.1 shows that, for one or more early fatality magnitudes, the mean and median frequencies for the three PWRs of this study (Surry, Sequoyah, and Zion) and the median frequency for the RSS-PWR are similar and are less than 10^{-6} per reactor year. However, Table 11.1 also shows that these frequencies for the two BWRs of this study (Peach Bottom and Grand Gulf) are significantly lower than that for the RSS-BWR. For one or more early fatality magnitude, the median frequency is less than 10^{-6} per reactor year for the RSS-BWR; whereas, the mean and median frequencies are less than 10^{-8} per reactor year for Peach Bottom and less than 10^{-9} per reactor year for Grand Gulf.

Further, the comparison of the early fatality magnitudes in the median exceedance frequency

*RSS "release categories" are analogous to the source term groups in the present study but were developed by different procedures.

range of 10^{-9} to 10^{-7} per reactor year shows that the RSS estimates are significantly higher than the estimates for the five plants of this study.

Table 11.1 shows that for the one or more latent cancer fatality magnitudes, the mean and median frequencies of only one plant (Sequoyah) of this study and the median frequencies for the RSS-PWR and RSS-BWR are similar and are less than 10^{-4} per reactor year. However, these frequencies for the other four plants of this study are an order of magnitude lower than that for the RSS; i.e., less than 10^{-5} per reactor year.

The RSS estimates of latent cancer fatality magnitudes for the median exceedance frequency range of 10^{-9} to 10^{-5} per reactor year are higher (in some instances significantly higher) than those for the five plants of this study—except for Zion at the median exceedance frequency of 10^{-9} per reactor year where they are about equal.

There are several factors contributing to the differences in the frequency distributions of the offsite consequences for this study and the RSS. Some of these factors are mentioned below:

- Accident sequence frequency differences.
- Source term characterization difference. Most of the source terms of this study have two releases—an early release and a later release. Early fatalities from a source term are mostly the consequences of the early release. Cancer fatalities are the consequences of both early and later releases. On the other hand, the RSS source terms did not have such a breakdown in terms of early or later release. Therefore, the early fatalities from an RSS source term were the consequences of the entire release, as were the latent cancer fatalities.
- Consequence analyses for this study are site specific, using data for the site features described in Chapters 3 through 7. The RSS consequence analysis was generic; it used composite offsite data by averaging over 68 different sites.
- In the present study, evacuation to a distance of 10 miles is assumed; whereas, in the RSS, evacuation to a distance of 25 miles was assumed.
- Health effect models of this study are different from those of the RSS.
- Protective action guide dose levels for controlling the long-term exposure are different.
- There are other miscellaneous differences between the accident consequence models and input data used in this study and the RSS.
- Different procedures were used for constructing the CCDFs.

11.5 Uncertainties and Sensitivities

There are uncertainties in the CCDFs of the offsite consequence measures. Some of these uncertainties are inherited from the uncertainties in the source term group specifications and frequencies. However, even after disregarding the source term group uncertainties, there are significant uncertainties in the CCDFs of the consequence measures due to uncertainties in the modeling of atmospheric dispersion, deposition, and transport of the radionuclides; transfer of radionuclides in the terrestrial exposure pathways; emergency response and long-term countermeasures; dosimetry, shielding, and health effects; and uncertainties in the input data for the model parameters.

Because of time constraints, uncertainty analyses for the offsite consequences, except for the uncertainties due to variability of the site meteorology, have not been performed for this report. They are planned for future studies. For this study, only best estimate values of the parameters for representation of the natural processes have been used in MACCS. An analysis of sensitivity of the CCDFs to the alternative protective measure assumptions is provided in the following section.

11.6 Sensitivity of Consequence Measure CCDFs to Protective Measure Assumptions

Emergency response, such as evacuation, sheltering, and early relocation of people, has its greatest beneficial impact on the early fatality frequency distributions. The long-term protective measures, such as decontamination, temporary interdiction, and condemnation of contaminated land, property, and foods in accordance with various radiological protective action guides (PAGs), have their largest beneficial impact on the latent cancer fatality and population exposure frequency distributions.

11.6.1 Sensitivity of Early Fatality CCDFs to Emergency Response

Four alternative emergency response modes within the 10-mile EPZ, as characterized in Table

11. Offsite Consequences

11.5, are assumed in order to show the sensitivity of early fatality CCDFs to these response modes.

Table 11.6 summarizes the early fatality mean CCDFs in tabular form for Surry, Peach Bottom, Sequoyah, and Grand Gulf for two alternative emergency response modes, and Zion for all four alternative emergency response modes. Several inferences are drawn later in this section regarding the effectiveness of these alternative emergency response modes for the five plants based on these data. However, more analysis is needed to support these inferences for emergency response and to provide detailed insight into the underlying competing processes involved that diminish or enhance the effectiveness of any emergency response mode.

In particular, the effectiveness of evacuation is very site specific and source term specific. It is largely determined by two site parameters, namely, evacuation delay time and effective evacuation speed, and two source term parameters—warning time before release and energy associated with the release (which, during some meteorological conditions, could cause the radioactive plume to rise while being transported downwind). Therefore, it cannot be extrapolated across the source terms for a plant or across the plants for similar source terms.

The CCDFs discussed here include contributions from many source term groups. The effectiveness of any emergency response mode judged from the sensitivity of the early fatality mean CCDF for a plant is essentially the effectiveness for the dominant source terms in specific frequency intervals included in the CCDF. With these caveats, the inferences based on the data shown in Table 11.6 are as follows:

Zion

1. Evacuation from the 0-to-5 mile EPZ combined with sheltering in the 5-to-10 mile EPZ is as effective as evacuation from the entire 10-mile EPZ. Effectiveness of evacuation in close-in regions of radius less than 5 miles and sheltering in the outer regions will be evaluated in future studies. (See Chapter 13.)
2. Sheltering, due to better shielding protection indoors, is more effective than early relocation from the state of normal activity. (See Tables 11.3 and 11.5 for distinctions between evacuation, early relocation, and shel-

tering modes of response assumed in this study.)

Sequoyah

1. Evacuation is more effective than relocation for exceedance frequencies higher than 10^{-8} per reactor year.
2. In the low frequency region (i.e., 10^{-8} per reactor year or less), the early relocation mode is more effective than evacuation. This "crossover" of the early fatality mean CCDFs for the two response modes is likely because of the dominance of the low frequency large source terms that also have short warning times before release and/or high energy contents and calculated long evacuation delay time and slow effective evacuation speed. Because of the short warning time before release and a long delay between the warning and the start of evacuation, many evacuees become vulnerable to the radiation exposures from the passing plume and contaminated ground rather than escape these exposures. Because of the plume-rise effect (for the hot plumes), the peak values of the air and ground radionuclide concentrations occur at some distance farther from the plant. In such a case, the evacuees from close-in regions moving in the downwind direction move from areas of lower concentrations to areas of higher concentrations and receive a higher dose. It should be noted that, while evacuating, the people are out in the open and have minimal shielding protection. For the above situations, the sheltering mode also would show the same crossover effect.

However, the crossover effect showing that relocation or sheltering may be more effective than evacuation may not be realistic because of uncertainties in the consequence analysis.

Peach Bottom, Grand Gulf

The source terms and features of these two low population density sites make evacuation a very effective mode of offsite response.

Surry

Although entries in Table 11.6 show that evacuation is more effective than relocation from the state of normal activity, some low probability accident sequences for Surry are similar to those of Sequoyah (short warning times of the interfacing-system LOCA accident sequences and large

Table 11.5 Assumptions on alternative emergency response modes within 10-mile plume exposure pathway EPZ for sensitivity analysis.

-
- a. Evacuation (see Table 11.3).
 - b. Early relocation in lieu of evacuation or shelter: Extends the assumptions for relocation outside the 10-mile EPZ (see Table 11.3) inward up to the plant site boundary.
 - c. Sheltering* (getting to and remaining indoors) in lieu of evacuation, followed by fast relocation after plume passage.
 - d. Evacuation for the inner 0-5 mile region and sheltering* in the outer 5-10 mile region followed by fast relocation after plume passage.
-

*Sheltering assumptions details: After an initial delay of 45 minutes from the reactor operator's warning, people get indoors and remain indoors and are relocated to uncontaminated areas within a maximum of 24 hours of remaining indoors. However, virtually all source terms analyzed in this study have two release phases—an early (first) release and a later (second) release. If there is a sufficient time gap (about 4 hours) between the two release phases, then people from indoors can be relocated to uncontaminated areas during this gap and avoid the exposure from the second release. With this perspective, two cases of relocation earlier than 24 hours are implemented in calculations as follows:

- Relocation within 4 hours after termination of the initial (the first) release, if the second release does not occur within this 4 hours; otherwise,
- Relocation within 4 hours after termination of the second release (provided this relocation time is earlier than 24 hours of indoor occupancy; otherwise, relocation is at 24 hours of indoor occupancy).

The dose for the above extra 4-hour period is assumed to account for the dose during the period of waiting for the plume to leave the area after termination of the release and the dose during people's transit to the relocation areas.

11. Offsite Consequences

Table 11.6 Sensitivity of mean CCDF of early fatalities to assumptions on offsite emergency response.

| Exceedance Frequency (ry ⁻¹) | 10-mile EPZ Emergency Response Mode* | Early Fatalities (persons) | | | | |
|--|--------------------------------------|----------------------------|--------------|----------|------------|-------------------|
| | | Surry | Peach Bottom | Sequoyah | Grand Gulf | Zion |
| 10 ⁻⁵ | a. Evacuation | 0/0 | 0/0 | 0 | 0 | 0 |
| | b. Relocation | 0/0 | 0/0 | 0 | 0 | 0 |
| | c. Shelter | ** | ** | ** | ** | 0 |
| | d. Evac/Shelter | ** | ** | ** | ** | 0 |
| 10 ⁻⁶ | a. Evacuation | 0/0 | 0/0 | 0 | 0 | 0 |
| | b. Relocation | 0/0 | 0/2(1) | 6(0) | 0 | 6(0) ^a |
| | c. Shelter | ** | ** | ** | ** | 0 |
| | d. Evac/Shelter | ** | ** | ** | ** | 0 |
| 10 ⁻⁷ | a. Evacuation | 0/0 | 0/0 | 5(1) | 0 | 2(2) |
| | b. Relocation | 2(1)/0 | 1(1)/1(2) | 7(1) | 2(0) | 1(3) |
| | c. Shelter | ** | ** | ** | ** | 7(2) |
| | d. Evac/Shelter | ** | ** | ** | ** | 2(2) |
| 10 ⁻⁸ | a. Evacuation | 4(1)/0 | 0/0 | 4(2) | 0 | 3(3) |
| | b. Relocation | 2(2)/0 | 7(1)/3(2) | 2(2) | 2(1) | 8(3) |
| | c. Shelter | ** | ** | ** | ** | 6(3) |
| | d. Evac/Shelter | ** | ** | ** | ** | 3(3) |
| 10 ⁻⁹ | a. Evacuation | 1(2)/1(1) | 0/0 | 2(3) | 0 | 4(3) |
| | b. Relocation | 9(2)/5(1) | 2(2)/5(2) | 6(2) | 8(1) | 2(4) |
| | c. Shelter | ** | ** | ** | ** | 9(3) |
| | d. Evac/Shelter | ** | ** | ** | ** | 4(3) |

Note: Under each plant name, the first entry is for the internal initiators and the second entry is for fire.

*See Table 11.3 for assumptions.

**No data

a. 6(0) = 6x10⁰ = 6

thermal energy for the sequences with early containment failure at vessel breach). Analyses of the sensitivity of early fatality CCDFs to sheltering, or a combination of evacuation and sheltering, have not been performed for Surry (nor for Peach Bottom, Sequoyah, and Grand Gulf).

11.6.2 Sensitivity of Latent Cancer Fatality and Population Exposure CCDFs to Radiological Protective Action Guide (PAG) Levels for Long-Term Countermeasures

The potential for latent cancer fatalities and population exposure is assumed to exist down to any low level of radiation dose and, therefore, over the entire site region. Although both early and chronic exposure pathways contribute to these consequence measures, only the chronic exposure pathways are expected to be mitigated by the long-term countermeasures such as decontamination, temporary interdiction, or condemnation of contaminated land, property, and foods based on guidance provided by responsible Federal agencies in terms of PAGs. This implies that, if the radiation dose to an individual from a

chronic exposure pathway would be projected to exceed the PAG (or intervention) level for that pathway, countermeasures should be undertaken to reduce the projected dose from the pathway so that it does not exceed the PAG level. Therefore, the latent cancer fatalities and the population exposures stemming from the chronic exposure pathways are expected to be sensitive to the PAG values.

The chronic exposure pathways base case PAGs are shown in Table 11.3. The only alternative PAG used for this sensitivity analysis is the RSS PAG for the groundshine dose to an individual for continuing to live in the contaminated environment. The RSS PAG adopted here is 25-rem EDE from groundshine and inhalation of resuspended radionuclides (instead of the RSS 25-rem whole body dose from groundshine only) in 30 years. This alternative is used to replace the base case PAG of 4-rem EDE in 5 years.

Summaries of the latent cancer fatality and population exposure mean CCDFs for both cases for the five plants for the internal initiating events are shown in Table 11.7.

Table 11.7 shows that there is practically no difference between the consequence magnitudes for the five plants for the two PAGs for continuing to live in the contaminated environment at the exceedance frequency of 10^{-5} per reactor year. This is because the source terms with frequency 10^{-5} per reactor year or higher have low release magnitudes such that the resulting environmental contaminations are below both the EPA and RSS PAG-based trigger levels for protective actions (i.e., no protective actions are needed).

At lower exceedance frequencies, source terms with larger release magnitudes contribute and the two PAGs reduce the consequences to different extents. The RSS PAG is less restrictive than the EPA PAG. Thus, the long-term consequence magnitudes with the RSS PAG are generally higher than those with the EPA PAG at equal exceedance frequencies. However, the economic consequences, discussed in the supporting contractor reports (Refs. 11.5 through 11.9), would show just the opposite behavior, i.e., economic consequences would be higher for the EPA PAG than for the RSS PAG.

Table 11.7 Sensitivity of mean CCDFs of latent cancer fatalities and population exposures to the PAGs for living in contaminated areas—internal initiating events.

| Exceedance Frequency (ry ⁻¹) | Cancer Fatalities (persons) | | | | | 50-Mile Pop. Exp. (person-rem) | | | | | Entire Region Pop. Exp. (person-rem) | | | | |
|--|-----------------------------|------|-------------------|------|------|--------------------------------|------|------|------|------|--------------------------------------|------|------|------|------|
| | 1* | 2* | 3* | 4* | 5* | 1* | 2* | 3* | 4* | 5* | 1* | 2* | 3* | 4* | 5* |
| 10⁻⁵ | | | | | | | | | | | | | | | |
| EPA ⁺ | 0 | 0 | 6(1) ^a | 0 | 0 | 7(2) | 0 | 1(5) | 0 | 5(3) | 2(3) | 0 | 4(5) | 0 | 9(3) |
| RSS ⁺ | 0 | 0 | 6(1) | 0 | 0 | 7(2) | 0 | 1(5) | 0 | 5(3) | 2(3) | 0 | 4(5) | 0 | 9(3) |
| 10⁻⁶ | | | | | | | | | | | | | | | |
| EPA | 1(3) | 1(3) | 4(3) | 3(2) | 8(3) | 1(6) | 3(6) | 3(6) | 2(5) | 2(7) | 8(6) | 7(6) | 2(7) | 2(6) | 5(7) |
| RSS | 2(3) | 2(3) | 5(3) | 3(2) | 1(4) | 2(6) | 4(6) | 5(6) | 2(5) | 3(7) | 1(7) | 1(7) | 3(7) | 2(6) | 8(7) |
| 10⁻⁷ | | | | | | | | | | | | | | | |
| EPA | 8(3) | 8(3) | 9(3) | 1(3) | 3(4) | 8(6) | 1(7) | 8(6) | 6(5) | 8(7) | 5(7) | 5(7) | 6(7) | 9(6) | 2(8) |
| RSS | 9(3) | 1(4) | 1(4) | 2(3) | 4(4) | 1(7) | 2(7) | 1(7) | 1(6) | 2(8) | 6(7) | 7(7) | 6(7) | 1(7) | 2(8) |
| 10⁻⁸ | | | | | | | | | | | | | | | |
| EPA | 2(4) | 2(4) | 2(4) | 3(3) | 8(4) | 2(7) | 2(7) | 2(7) | 1(6) | 2(8) | 1(8) | 1(8) | 9(7) | 2(7) | 3(8) |
| RSS | 2(4) | 4(4) | 2(4) | 4(3) | 1(5) | 2(7) | 4(7) | 2(7) | 2(6) | 3(8) | 2(8) | 2(8) | 1(8) | 2(7) | 4(8) |
| 10⁻⁹ | | | | | | | | | | | | | | | |
| EPA | 4(4) | 4(4) | 2(4) | 6(3) | 1(5) | 3(7) | 4(7) | 4(7) | 2(6) | 4(8) | 2(8) | 2(8) | 1(8) | 3(7) | 4(8) |
| RSS | 5(4) | 4(4) | 3(4) | 6(3) | - | 4(7) | 6(7) | 4(7) | 3(6) | 4(8) | 3(8) | 5(8) | 2(8) | 4(7) | 4(8) |

* Plant Names: 1 = Surry; 2 = Peach Bottom; 3 = Sequoyah; 4 = Grand Gulf; 5 = Zion

+ Long-term relocation PAGs:

EPA = 4-rem EDE in 5 years from groundshine—an approximation of EPA-proposed long-term relocation PAG

RSS = 25-rem EDE in 30 years from groundshine—RSS long-term relocation PAG

a. 6(1) = 6 X 10¹ = 60

REFERENCES FOR CHAPTER 11

- 11.1 U.S. Nuclear Regulatory Commission, "Reactor Safety Study—An Assessment of Accident Risks in U.S. Commercial Nuclear Power Plants," WASH-1400 (NUREG-75/014), October 1975.
- 11.2 D. I. Chanin, H. Jow, J. A. Rollstin et al., "MELCOR Accident Consequence Code System (MACCS)," Sandia National Laboratories, NUREG/CR-4691, Vols. 1-3, SAND86-1562, February 1990.
- 11.3 U.S. Department of Health and Human Services/Food and Drug Administration, "Accidental Radioactive Contamination of Human Food and Animal Feeds; Recommendations for State and Local Agencies," *Federal Register*, Vol. 47, No. 205, pp. 47073-47083, October 22, 1982.
- 11.4 U.S. Environmental Protection Agency, "Manual of Protective Action Guides and Protective Actions for Nuclear Incidents," Draft, 1989.
- 11.5 R. J. Breeding et al., "Evaluation of Severe Accident Risks: Surry Unit 1," Sandia National Laboratories, NUREG/CR-4551, Vol. 3, Revision 1, SAND86-1309, October 1990.
- 11.6 A. C. Payne, Jr., et al., "Evaluation of Severe Accident Risks: Peach Bottom Unit 2," Sandia National Laboratories, NUREG/CR-4551, Vol. 4, Draft Revision 1, SAND86-1309, to be published.*
- 11.7 J. J. Gregory et al., "Evaluation of Severe Accident Risks: Sequoyah Unit 1," Sandia National Laboratories, NUREG/CR-4551, Vol. 5, Revision 1, SAND86-1309, December 1990.
- 11.8 T. D. Brown et al., "Evaluation of Severe Accident Risks: Grand Gulf Unit 1," Sandia National Laboratories, NUREG/CR-4551, Vol. 6, Draft Revision 1, SAND86-1309, to be published.*
- 11.9 C. K. Park et al., "Evaluation of Severe Accident Risks: Zion Unit 1," Brookhaven National Laboratory, NUREG/CR-4551, Vol. 7, Draft Revision 1, BNL-NUREG-52029, to be published.*

*Available in the NRC Public Document Room, 2120 L Street NW., Washington, DC.

12. PERSPECTIVES ON PUBLIC RISK

12.1 Introduction

One of the objectives of this study has been to gain and summarize perspectives regarding risk to public health from severe accidents at the five studied commercial nuclear power plants. In this chapter, risk measures for these plants are compared and perspectives drawn from these comparisons.

As discussed in Chapter 2, the quantitative assessment of risk involves combining severe accident sequence frequency data with corresponding containment failure probabilities and offsite consequence effects. An important aspect of the risk estimates in this study is the explicit treatment of uncertainties. The risk information discussed here includes estimates of the mean and the median of the distributions of the risk measures and the 5th percentile and the 95th percentile values. The risk results obtained have been analyzed with respect to major contributing accident sequences, plant-specific design and operational features, and accident phenomena that play important roles.

The assessments of plant risk that support the discussions of this chapter are discussed in detail in References 12.1 through 12.7 and summarized in Chapters 3 through 7 for the five individual plants. Appendix C to this report provides more detailed information on certain technical issues important to the risk studies. This work was performed by Sandia National Laboratories (on the Surry, Sequoyah, Peach Bottom, and Grand Gulf plants) and Idaho National Engineering Laboratory and Brookhaven National Laboratory (on the Zion plant).

12.2 Summary of Results

Estimates of risk presented in Chapters 3 through 7 for the five plants studied are compared in this section. Risk measures that are used for these comparisons are: early fatality, latent cancer fatality, average individual early fatality, and average individual latent cancer fatality risks for internally initiated and externally initiated (fire) events (additional risk measures are provided in Refs. 12.3 through 12.7). For reasons discussed in Chapter 1, seismic risk is not discussed here.

In order to display the variabilities in the noted risk measures, the early fatality and latent cancer

fatality risk results of all five plants from internally initiated accidents are plotted together in Figure 12.1. Individual early fatality and latent cancer fatality risks from internally initiated accidents are compared with the NRC safety goals* (Ref. 12.8) in Figure 12.2. Similar risk results from externally initiated (fire) accidents for the Surry and Peach Bottom plants are presented in Figures 12.3 and 12.4. Estimates of the frequencies of a "large release" of radioactive material (using a definition of large as a release that results in one or more early fatalities) are presented in Figure 12.5.

Based on the results of the risk analyses for the five plants, a number of general conclusions can be drawn:

- The risks to the public from operation of the five plants are, in general, lower than the Reactor Safety Study (Ref. 12.10) estimates for two plants in 1975. Among the five plants studied, the two BWRs show lower risks than the three PWRs, principally because of the much lower core damage frequencies estimated for these two plants, as well as the mitigative capabilities of the BWR suppression pools during the early portions of severe accidents.
- Individual early fatality and latent cancer fatality risks from internally initiated events for all of these five plants, and from fire-initiated accidents for Surry and Peach Bottom, are well below the NRC safety goals.
- Fire-initiated accident sequences have relatively minor effects on the Surry plant risk compared to the risks from internal events but have a significant impact on Peach Bottom risk.
- The Surry and Zion plants benefit from their strong and large containments and therefore have lower conditional early containment failure probabilities. The Peach Bottom and Grand Gulf have higher conditional probabilities of early failure, offsetting to some degree the risk benefits of estimated lower core damage frequencies for these plants.

*Throughout this report, discussion of and comparison with the NRC safety goals relates specifically and only to the two quantitative health objectives identified in the Commission's policy statement (Ref. 12.8).

12. Public Risk

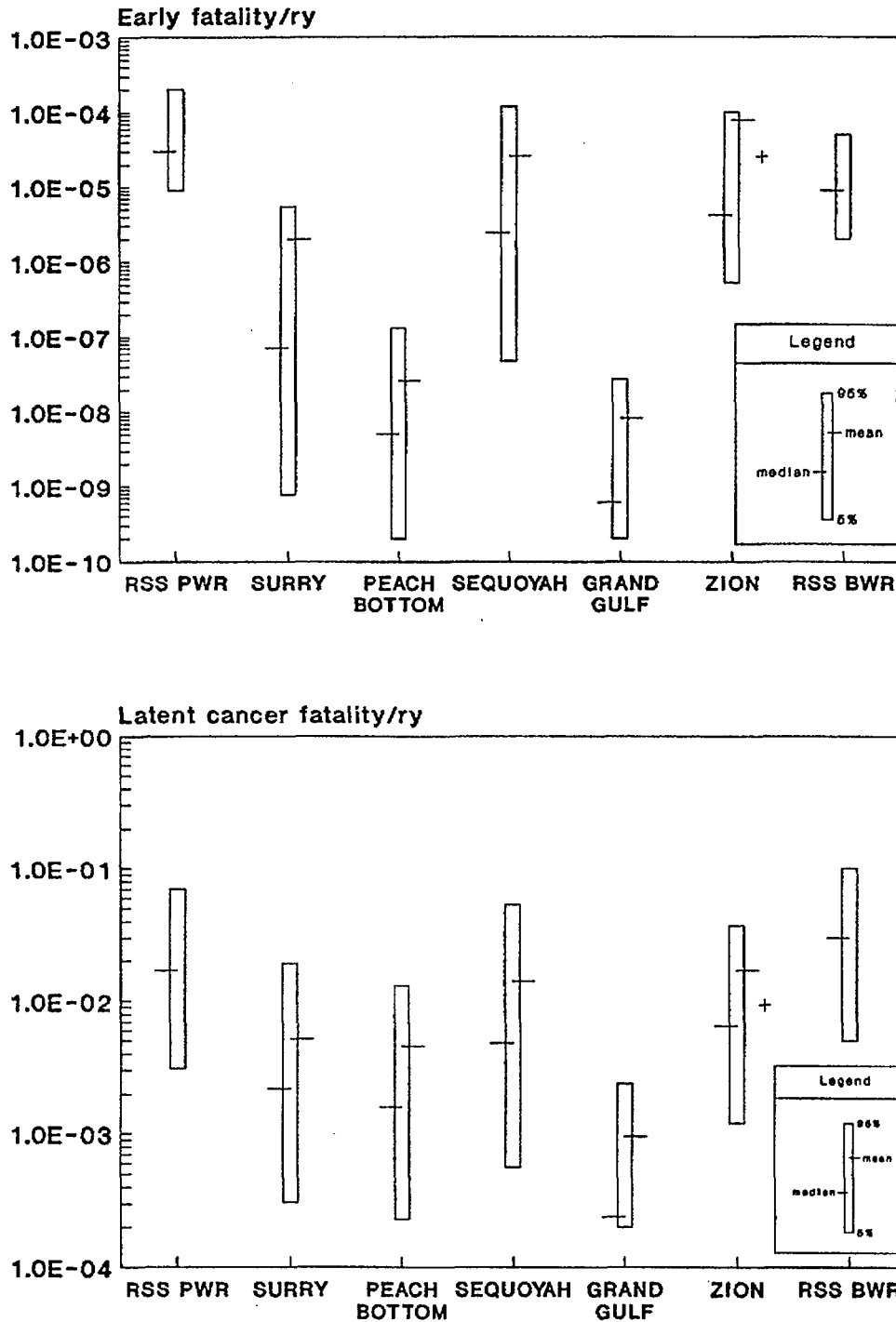

Notes: As discussed in Reference 12.9, estimated risks at or below 1E-7 should be viewed with caution because of the potential impact of events not studied in the risk analyses.

"+" indicates recalculated mean value based on recent modifications to the Zion plant (as discussed in Section C.15).

Figure 12.1 Comparison of early and latent cancer fatality risks at all plants (internal events).

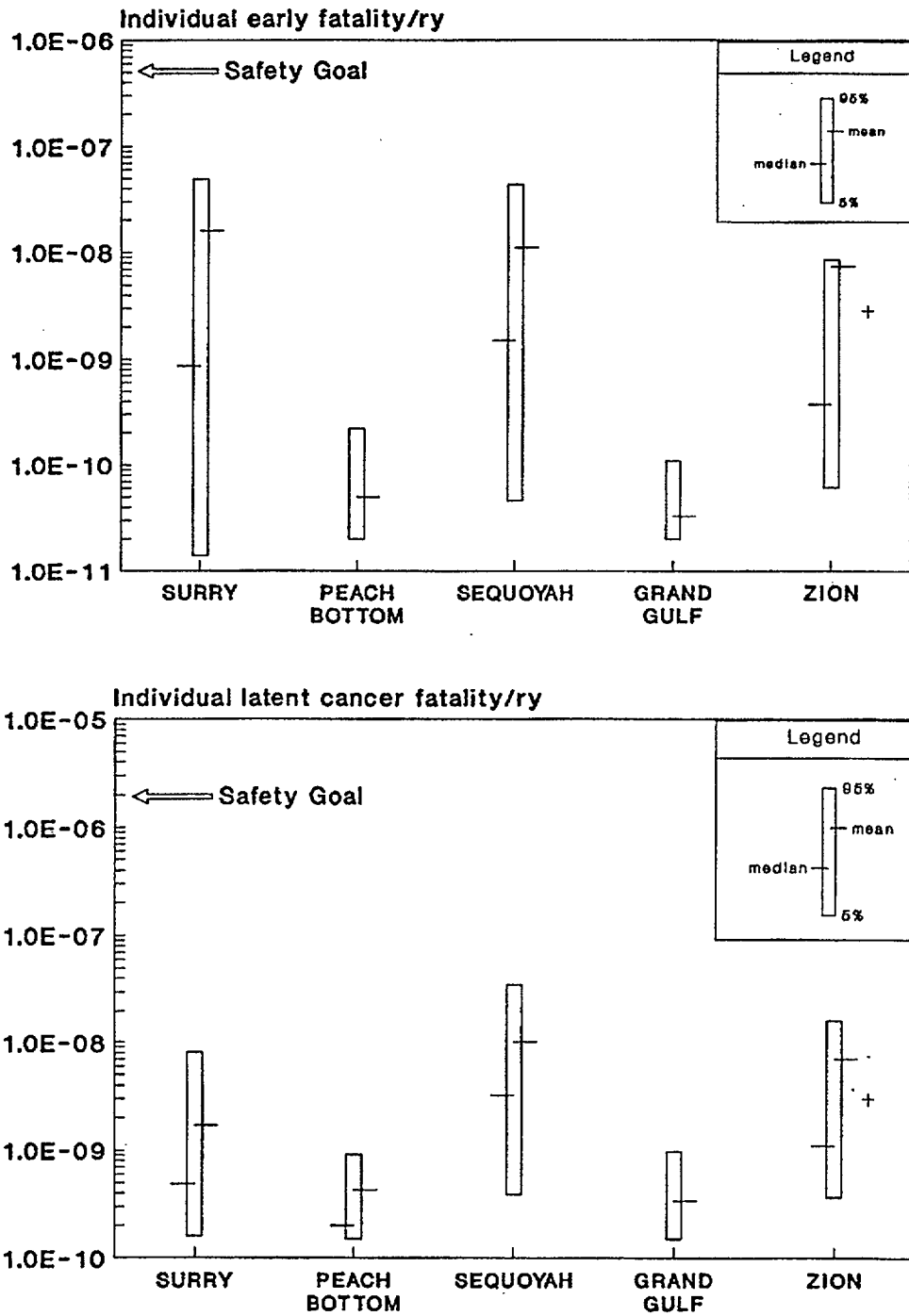

Notes: As discussed in Reference 12.9, estimated risks at or below 1E-7 should be viewed with caution because of the potential impact of events not studied in the risk analyses.

"+" indicates recalculated mean value based on recent modifications to the Zion plant (as discussed in Section C.15).

Figure 12.2 Comparison of risk results at all plants with safety goals (internal events).

12. Public Risk

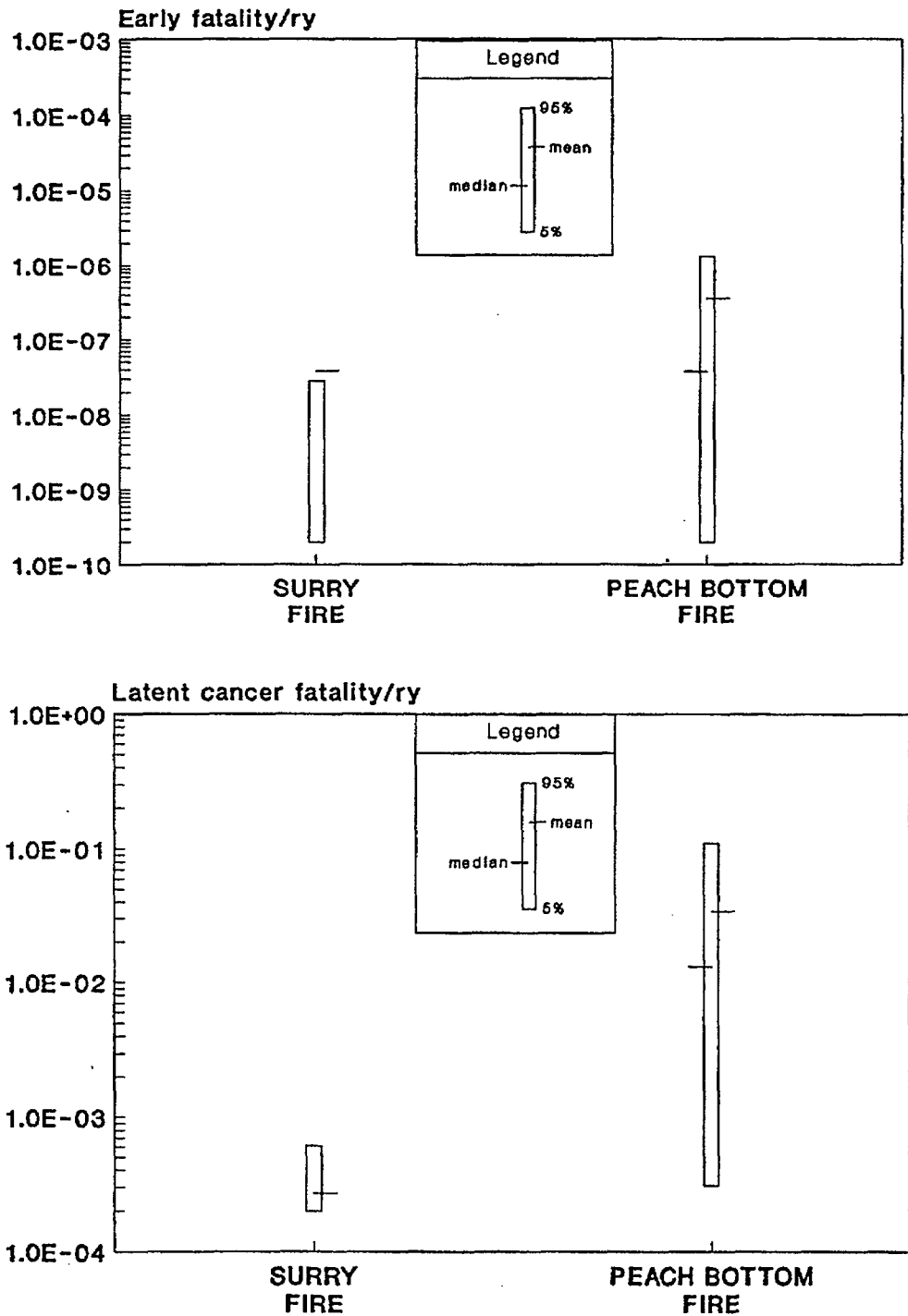

Note: As discussed in Reference 12.9, estimated risks at or below 1E-7 should be viewed with caution because of the potential impact of events not studied in the risk analyses.

Figure 12.3 Comparison of early and latent cancer fatality risks at Surry and Peach Bottom (fire-initiated accidents).

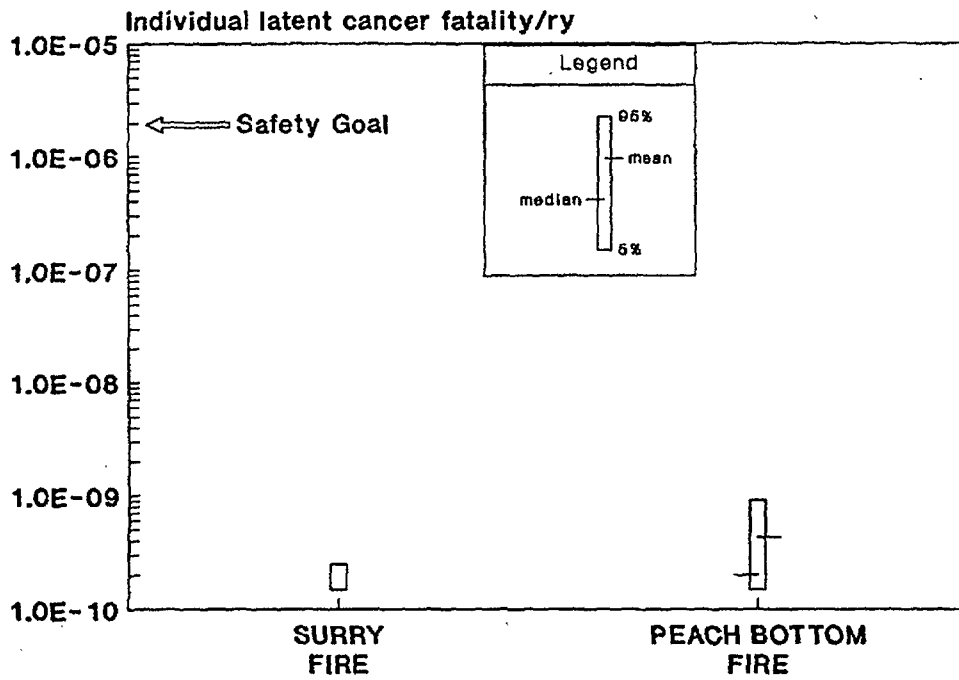
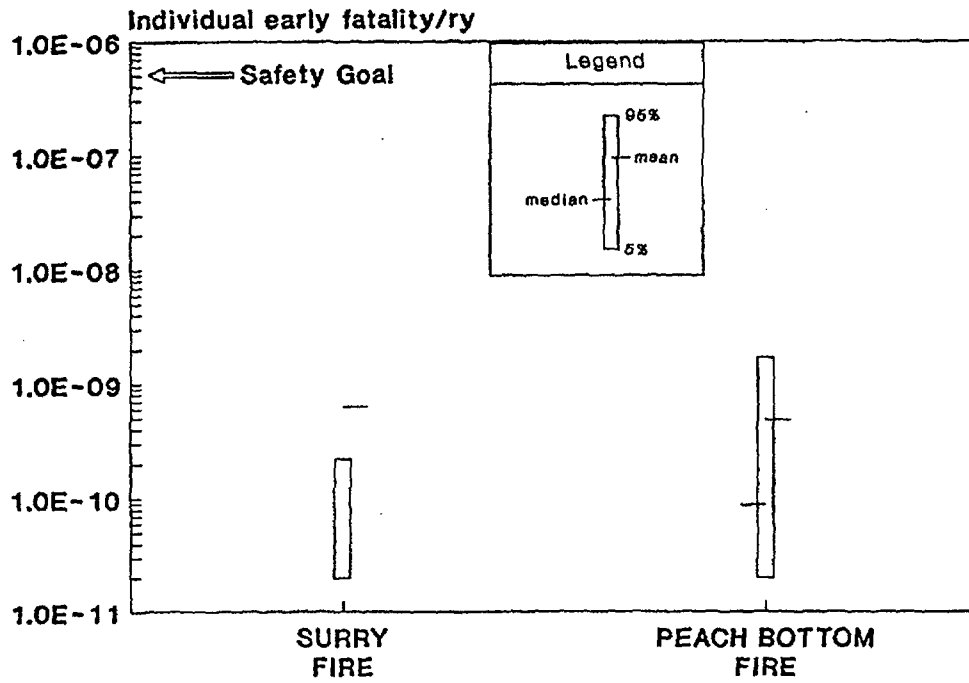

Note: As discussed in Reference 12.9, estimated risks at or below 1E-7 should be viewed with caution because of the potential impact of events not studied in the risk analyses.

Figure 12.4 Comparison of risk results at Surry and Peach Bottom with safety goals (fire-initiated accidents).

12. Public Risk

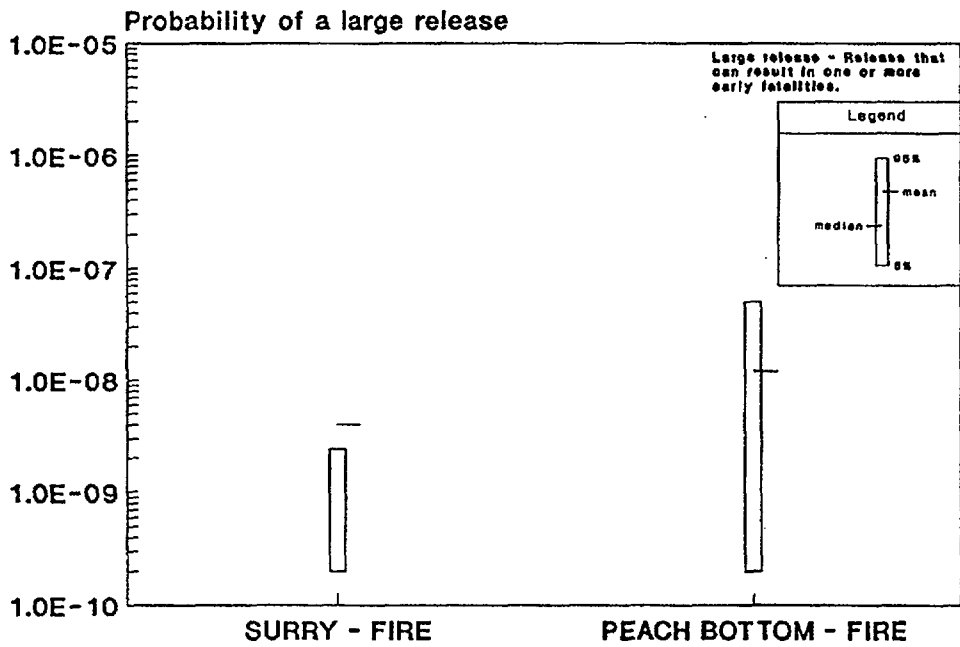
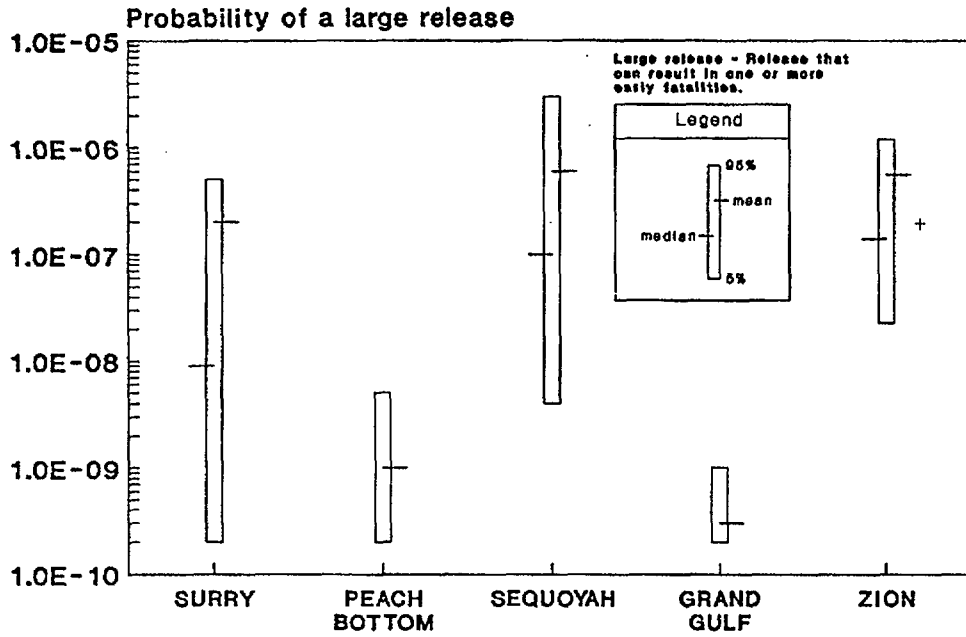

Notes: As discussed in Reference 12.9, estimated risks at or below 1E-7 should be viewed with caution because of the potential impact of events not studied in the risk analyses.

"+" indicates recalculated mean value based on recent modifications to the Zion plant (as discussed in Section C.15).

Figure 12.5 Frequency of one or more early fatalities at all plants.

- The principal challenges to containment structures vary considerably among the five plants studied. Hydrogen combustion is a significant threat to the Sequoyah and Grand Gulf plants (in part because of the inoperability of ignition systems in some key accident sequences), while direct attack of the containment structure by molten core material is most important in the Peach Bottom plant. Few physical processes were identified that could seriously challenge the Surry and Zion containments.
- Emergency response parameters (warning time, evacuation speed, etc.) appear to have a significant impact on early fatality risk but almost no effect on latent cancer fatality risk.

12.3 Comparison with Reactor Safety Study

Results of the present study (for internal initiators) are compared with the Surry and Peach Bottom results in the Reactor Safety Study (RSS) in Figure 12.1. In general, for the early fatality risk measure, the Surry risk estimates in this study are lower than the corresponding RSS PWR values. Similarly, the present Peach Bottom risk estimates are lower than the RSS BWR estimates. For the latent cancer fatality risk measure, the patterns in the results are less clear; the RSS risk estimates for both of the plants lie in the upper portion of the risk estimates of this study.

Focusing on the major contributors to risk, it may be seen that, in the RSS, the Surry risk was dominated by interfacing-system LOCA (the V sequence), station blackout (TMLB'), and small LOCA sequences, with hydrogen burning and overpressure failures of containment. While the estimated risks of the interfacing-system LOCA accident sequence are lower in the present study because of a lower estimated frequency, it is still an important contributor to risk. Also important (because of their large source terms) are containment bypass accidents initiated by steam generator tube rupture, compounded by operator errors (which result in core damage) and subsequent stuck-open safety-relief valves on the secondary side. Early overpressurization containment failure at Surry is much less probable.

In the Peach Bottom analysis of the RSS, risk was dominated by transient-initiated events with loss of heat removal (TW type of sequence) and ATWS accidents with failure of containment prior

to vessel breach. Dominant containment failure modes were from steam overpressurization. In the present study, risk is dominated by long-term station blackout and ATWS accident sequences. The dominant containment failure mode is drywell meltthrough.

The RSS did not perform an analysis of accidents initiated by fires. As such, comparisons of the present study's fire risk estimates with the RSS are not possible.

Since the publication of the RSS in 1975, a vast amount of work has been done in all areas of risk analysis, funded by government agencies and the nuclear industry. Major improvements have been made in the understanding of severe accident phenomenology and approaches to quantification of risk, many of which have been used in this study. These efforts have helped in lowering the estimates of overall risk levels in the present study to some extent by reducing the use of conservative and bounding types of analyses. Equally important, some plants have made modifications to plant systems or procedures based on PRAs, lessons learned from the Three Mile Island accident, etc., thus reducing risk. On the other hand, new issues have been raised and the possibility of new phenomena such as direct containment heating and drywell meltthrough has been introduced, which added to the previous estimates of risk. For issues that are not well understood, expert judgments were elicited that frequently showed diverse conclusions. The net effect of this improved understanding is that total plant risk estimates are lower than the RSS estimates, but the distributions of these risk measures are very broad.

12.4 Perspectives

As discussed above, plant-specific features contribute largely to the estimates of risks. In order to compare the variables and characteristics of the three PWR plants (Surry, Sequoyah, and Zion) and two BWR plants (Peach Bottom and Grand Gulf) in this study, the dominant contributors to early and latent cancer fatality risks for the PWRs and BWRs from internally initiated events are shown in Figures 12.6 through 12.10. Dominant contributors to risk from fire-initiated accidents for Surry and Peach Bottom are compared in Figure 12.9. Perspectives on risks for the five plants from these comparisons, supplemented by information in the supporting contractor reports (Refs. 12.1 through 12.7) are discussed below.

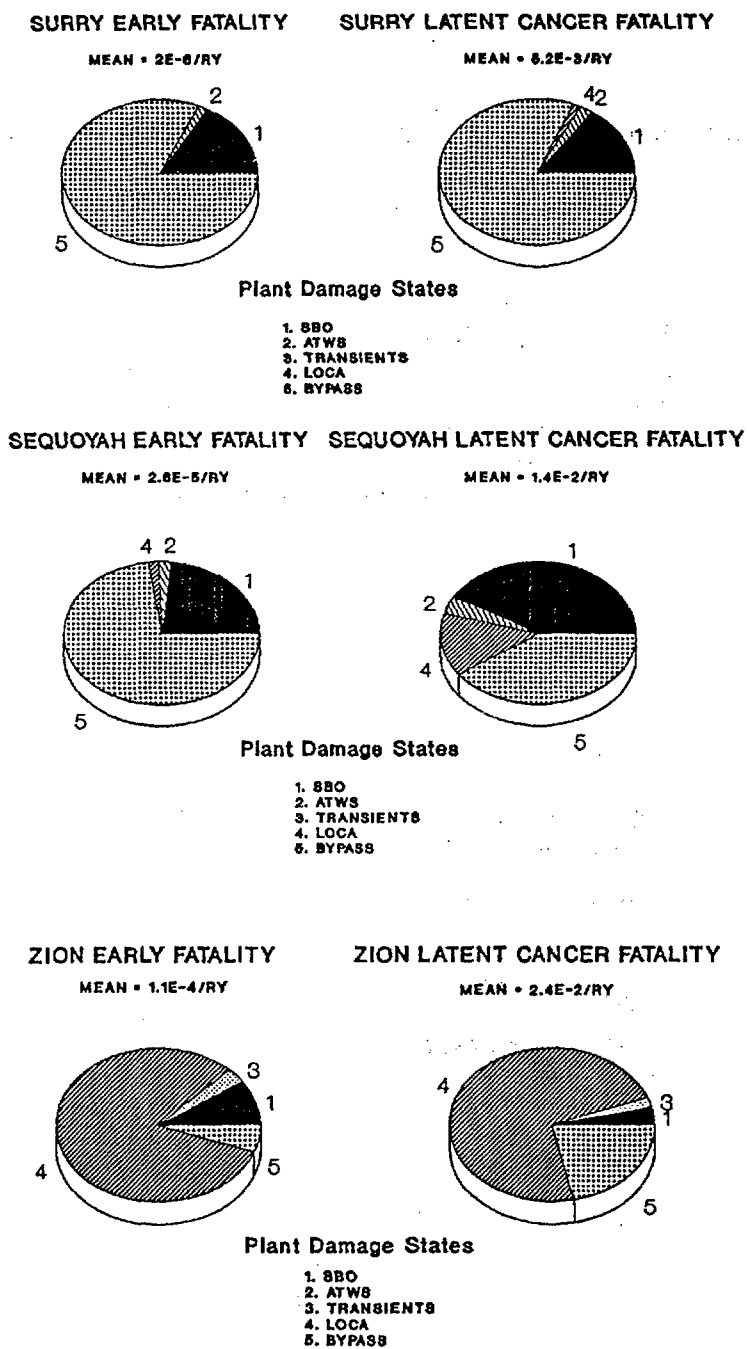

Figure 12.6 Contributions of plant damage states to mean early and latent cancer fatality risks for Surry, Sequoyah, and Zion (internal events).

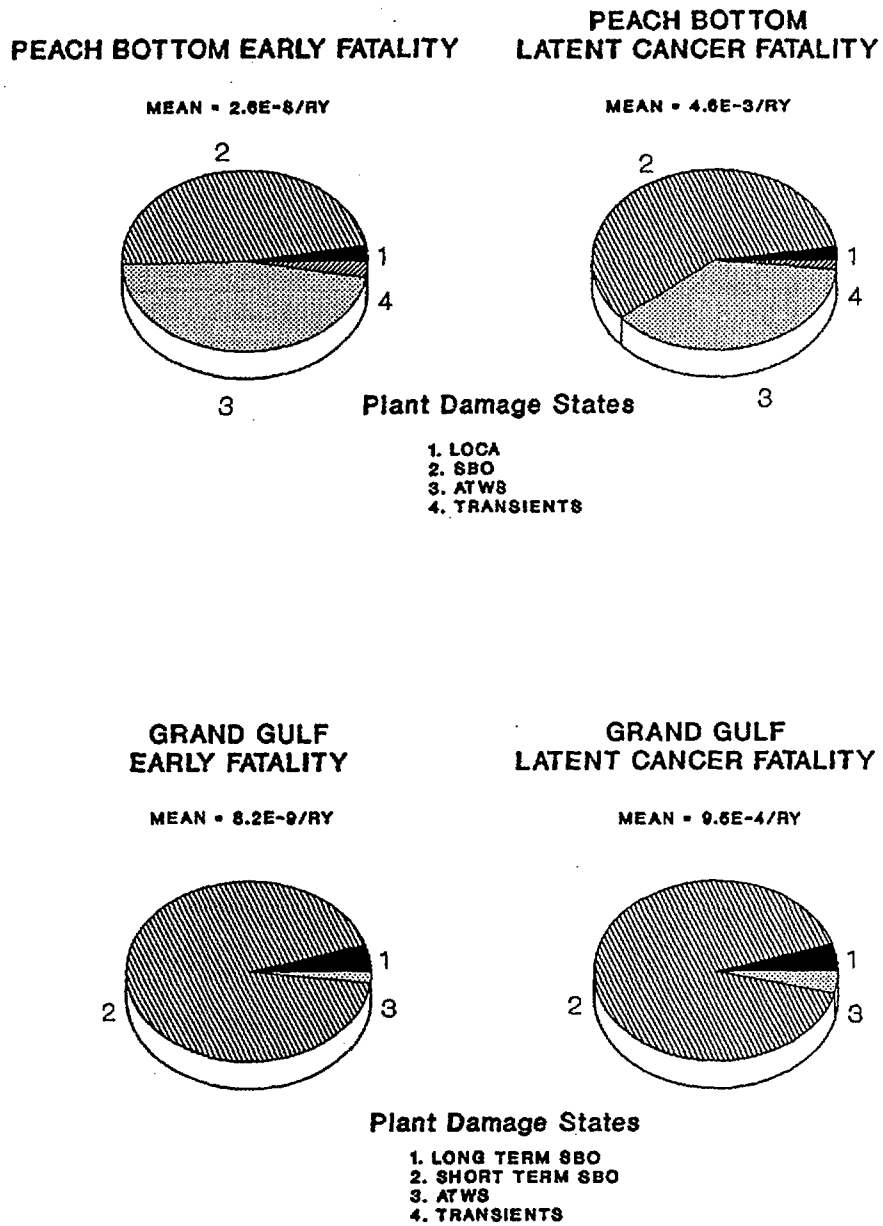

Figure 12.7 Contributions of plant damage states to mean early and latent cancer fatality risks for Peach Bottom and Grand Gulf (internal events).

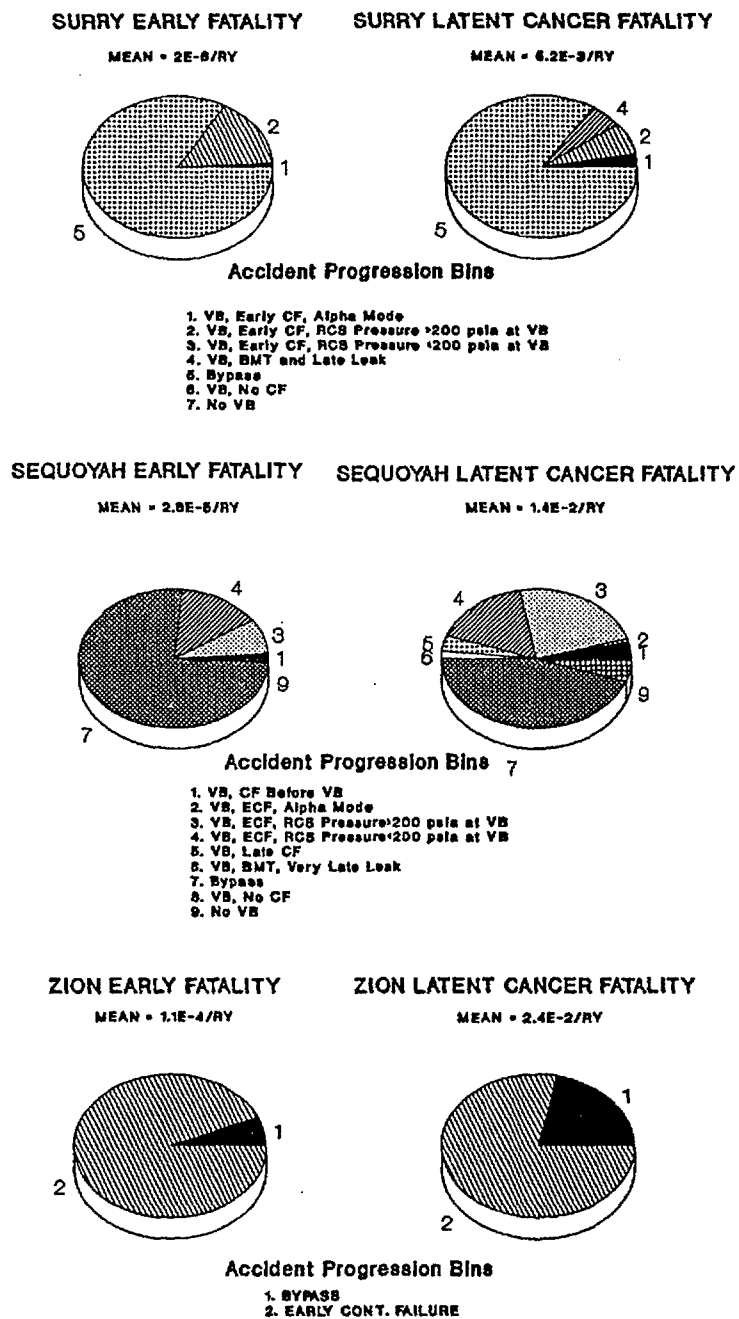

Figure 12.8 Contributions of accident progression bins to mean early and latent cancer fatality risks for Surry, Sequoyah, and Zion (internal events).

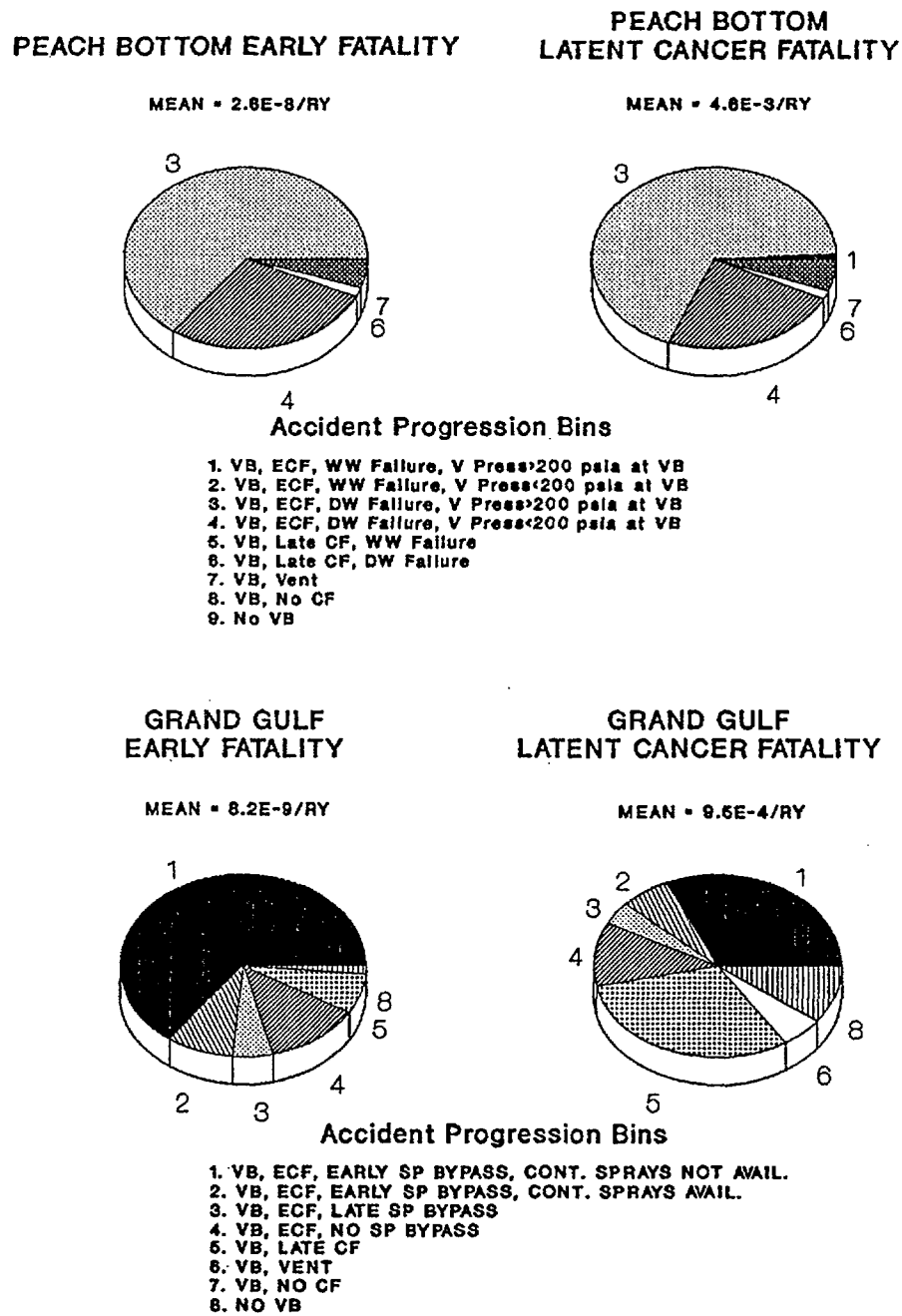
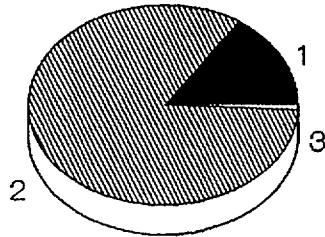

Figure 12.9 Contributions of accident progression bins to mean early and latent cancer fatality risks for Peach Bottom and Grand Gulf (internal events).

**SURRY EARLY FATALITY
(FIRE)**

MEAN = $3.8E-8$ /RY



**SURRY LATENT CANCER FATALITY
(FIRE)**

MEAN = $2.7E-4$ /RY

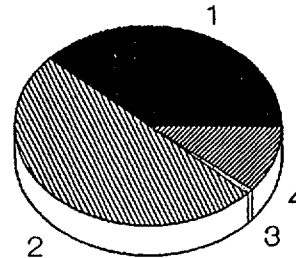

Accident Progression Bins

- 1. VB, Early CF, Alpha Mode
- 2. VB, Early CF, RCS Pressure >200 psia at VB
- 3. VB, Early CF, RCS Pressure <200 psia at VB
- 4. VB, BMT and Late Leak
- 6. Bypass
- 8. VB, No CF
- 7. No VB

**PEACH BOTTOM EARLY FATALITY
(FIRE)**

MEAN = $3.5E-7$ /RY

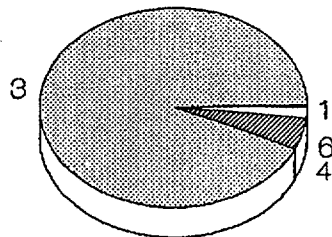

**PEACH BOTTOM
LATENT CANCER FATALITY
(FIRE)**

MEAN = $3.4E-2$ /RY

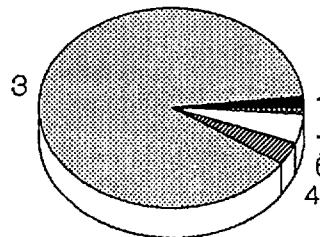

Accident Progression Bins

- 1. VB, ECF, WW Failure, V Press >200 psia at VB
- 2. VB, ECF, WW Failure, V Press <200 psia at VB
- 3. VB, ECF, DW Failure, V Press >200 psia at VB
- 4. VB, ECF, DW Failure, V Press <200 psia at VB
- 6. VB, Late CF, WW Failure
- 8. VB, Late CF, DW Failure
- 7. VB, Vent
- 8. VB, No CF
- 9. No VB

Figure 12.10 Contributions of accident progression bins to mean early and latent cancer fatality risks for Surry and Peach Bottom (fire-initiated accidents).

Accident Sequences Important to Risk

- Mean early fatality risks at Surry and Sequoyah and latent cancer fatality risk at Surry are dominated by bypass accidents (Event V and steam generator tube rupture accidents). Sequoyah latent cancer risk is dominated equally by loss of offsite power sequences and bypass accidents. The risk at Zion is dominated by medium LOCA sequences resulting from the failure of reactor coolant pump seals, induced by failures of the component cooling water system (CCWS) or service water system. Zion has the feature that CCWS (supported by the service water system) cools both the reactor coolant pump seals and high-pressure injection pump oil coolers, thus creating the potential for a common-mode failure. (As discussed in Chapter 7, steps have been taken by the plant licensee to address this dependency.)
- BWR risks are driven by events that fail a multitude of systems (i.e., reduce the redundancy through some common-mode or support system failure) or events that require a small number of systems to fail in order to get to core damage, such as ATWS sequences. The accidents important to both early fatality and latent cancer fatality risk at Peach Bottom are station blackouts and ATWS; the accident most important at Grand Gulf is station blackout.
- For the Peach Bottom plant, the estimated risks from accidents initiated by fires, while low, are greater than those from accidents initiated by internal events. Fire-initiated accidents are similar to station blackout accidents in terms of systems failed and accident progression. As such, the conditional probability of early containment failure is relatively high, principally due to the drywell shell melt-through failure mode (see Chapter 9 for additional discussion) (the conditional probability is somewhat higher because of the lower probability of ac power recovery). For the Surry plant, the fire risks are estimated to be smaller than those from internal events. This is because of two reasons: the frequency of core damage from fire initiators is lower; and fire-initiated accidents result in low conditional probabilities of early containment failure. As noted above, the internal-event risks are dominated by containment bypass accidents.

Containment Failure Issues Important to Risk

- At Surry, containment bypass events (interfacing-system LOCAs and steam generator tube ruptures) are assessed to be most important to risk. Other containment failure modes of less importance are: static failure at the containment spring line from loads at vessel breach (i.e., direct containment heating loads, hydrogen burns, ex-vessel steam explosion loads, and steam blowdown loads); or containment failure from in-vessel steam explosions (the "alpha-mode" failure of the Reactor Safety Study). These failure modes have only a small probability of resulting in early containment failure.
 - At Zion, the conditional probability of early containment failure is small, comparable to that of Surry. Those containment failure modes that contribute to this small failure probability include alpha-mode failure, containment isolation failure, and overpressurization failure at vessel breach.
 - In previous studies, the potential impact of direct containment heating loads was found to be very important to risk. In this study, the potential impact is less significant for the Surry and Zion plants. Reasons for this reduced importance include:
 - Temperature-induced and other depressurization mechanisms that reduce the probability of reactor vessel breach at high reactor coolant system pressure, either eliminating direct containment heating (DCH) or reducing the pressure rise at vessel breach. These depressurization mechanisms are stuck-open power-operated relief valves, reactor coolant pump seal failures, accident-induced hot leg and surge line failures, and deliberate opening of PORVs by operators; and
 - The size and the strength of the Surry containment (the maximum DCH load has only a conditional probability of 0.3 of failing the containment).
- Additional discussion of the issue of direct containment heating may be found in Section 9.4.3 and Section C.5 of Appendix C.
- At Sequoyah, containment bypass events are assessed to be most important to mean early fatality risk. Another failure important to

12. Public Risk

early fatality risk is early failure of containment. In particular, the catastrophic rupture failure mode dominates early containment failures, which occur as a result of pre-vessel-breach hydrogen events and failures at vessel breach. The failures at vessel breach are the result of a variety of load sources (individually or in some combinations), including direct containment heating loads, hydrogen burns, direct contact of molten debris with the steel containment, alpha-mode failures, or loads from ex-vessel steam explosions. The bypass mode of containment failure and early containment failures dominate the mean latent cancer risk at Sequoyah and contribute about equally to this consequence measure.

- At Peach Bottom, drywell meltthrough is the most important mode of containment failure. Other containment failure modes of importance are: drywell overpressure failure, static failure of the wetwell (above as well as below the level of the suppression pool), and static failure at the drywell head.
- At Grand Gulf, the risk is most affected by containment failures in which both the drywell and the containment fail. As discussed in Chapter 9, roughly one-half the containment failures analyzed in this study also resulted in drywell failure. The principal causes of the combined failures were hydrogen combustion in the containment atmosphere and loads at reactor vessel breach (direct containment heating, ex-vessel steam explosions, or steam blowdown from the reactor vessel).

Source Term and Offsite Consequence Issues Important to Risk

- BWR suppression pools provide a significant benefit in severe accidents in that they effectively trap radioactive material (such as iodine and cesium) released early in the accident (before vessel breach) and, for some containment failure locations, after vessel breach as well.
- Accidents that bypass the containment structure compromise the many mitigative features of these structures and thus can have significant estimated radioactive releases. As noted above, such accidents dominated the risk for the Surry and Sequoyah plants.
- The design of the reactor cavity can significantly influence long-term releases of radio-

active material; if large amounts of water can enter the cavity (e.g., as at Sequoyah), releases during core-concrete interactions can be significantly mitigated.

- Site parameters such as population density and evacuation speeds can have a significant effect on some risk measures (e.g., early fatality risk). Other risk measures, such as latent cancer fatality risk and individual early fatality risk, are less sensitive to such parameters. Latent cancer fatality risks are sensitive to the assumed level of interdiction of land and crops. (These issues are discussed in more detail below.)

Factors Important to Uncertainty in Risk

In order to identify the principal sources of uncertainties in the estimated risk, regression analyses have been performed for each of the plants in this study. A stepwise linear model is used, and, in general, the dependent variable is a risk measure (e.g., early fatalities per year) although some study has been done on the Surry plant using frequencies of radionuclide releases (discussed in Section 10.4.3). The independent variables consisted of individual parameters and groups of correlated parameters. Also, the analyses are generally performed for the complete risk model, although in some cases analyses are performed on specific plant damage states. The extent to which this model accounted for the overall uncertainty (the R-square value) varied considerably, from roughly 30 percent in the analysis of latent cancer fatality risk in the Sequoyah plant to roughly 75 percent in the analysis of early fatality risk in the Surry plant.

The results of the regression analyses indicate the following:

- For Surry, the uncertainty in all risk measures is dominated by the uncertainties in parameters determining the frequencies of containment bypass accidents (interfacing-system LOCA and steam generator tube rupture (SGTR)) and the radioactive release magnitudes of these accidents. More specifically, the most important parameters are the initiating event frequencies for these bypass accidents, the fraction of the core radionuclide inventory released into the vessel, and the fraction of material in the vessel in an SGTR-initiated core damage accident that is released to the environment. With the high risk importance of bypass accidents, it is not surprising that uncertainties in bypass accident parameters are important to risk uncertainty,

while other parameters such as those relating to source terms in containment, containment strength, etc., are not found to be important.

- For Zion, the regression analyses also indicated that accident frequency and source term parameter uncertainties were most important. More specifically, the most important parameters were the initiating event frequencies for loss of component cooling water (CCW)/service water (SW), the failure to recover CCW/SW, the fraction of the core radionuclide inventory released into the vessel, the radionuclide containment transport fraction at vessel breach, and the fraction of radionuclides released to the environment through the steam generators. The importance of the loss of CCW/SW frequencies is not surprising, given the large contribution of accidents initiated by these events to the core damage frequency. Also, those source term parameters that influence the release fractions for early containment failure and bypass events are not surprisingly important to some risk measures. The only accident progression parameter that was demonstrated to be important to the uncertainty in risk was the probability of vessel and containment breach by an in-vessel steam explosion. This result occurs because the probability of early containment failure from all other causes is extremely low at Zion, so that (at these very low probability levels) uncertainty in the in-vessel steam explosion failure mode becomes more significant. The importance of the steam explosion failure mode is also more significant because the accident progression analysis for Zion indicates that the reactor coolant system (RCS) is not likely to be at high pressure when vessel breach occurs. This means that loads at vessel breach from direct containment heating are likely to be smaller than would have been the case if RCS pressure were high. Also, at low RCS pressure, the probability of triggering an in-vessel steam explosion is increased.
- For Sequoyah, the regression analysis for the complete risk model did not account for a large fraction of the uncertainty. As such, regression analyses were performed for individual plant damage states (PDSs). For the containment bypass PDSs (which dominated the mean risk at Sequoyah), the most important uncertainties related to accident frequency and source term issues. More specifically, for the interfacing-system LOCA PDS, the most

important parameter uncertainties were those for the initiating event frequency, the probability that releases will be scrubbed by fire sprays in the vicinity of the break, and the decontamination factor of the fire sprays. For the SGTR-initiated core damage accident, the most important parameters are the initiating event frequency, the fraction of the core radionuclide inventory released into the vessel, and the fraction of material in the vessel that is released to the environment.

For the station blackout, LOCA, and transient plant damage states, the uncertainty in early fatality risk is accounted for by parameters from the accident frequency, accident progression, and source term analysis, with none of these groups or any small set of parameters dominating. In this circumstance, the parameters relating to the containment failure pressure, the fraction of the core participating in a high-pressure melt ejection, and the pressure rise at vessel breach for low-pressure accident sequences appeared as somewhat important for each of these plant damage states (but, again, did not by themselves or in combination dominate the uncertainty estimation).

- For Peach Bottom, the regression analysis for the complete internal-event model indicated that the risk uncertainty is dominated by uncertainties in radioactive release uncertainties—more specifically, the dominating parameters relating to the fraction of the core radionuclide inventory released into the vessel before vessel breach, the fraction of the radionuclide inventory released during core-concrete interaction that is released from containment, and the fraction of the radionuclide inventory remaining in the core material at the initiation of core-concrete interaction that is released during that interaction.

The regression analysis on the fire risk model does not show such a clear domination by any parameters. The early fatality risk uncertainty is dominated by radioactive release parameters (the fraction of core radionuclide inventory released to the vessel before vessel breach, the fraction of radionuclide inventory remaining in the core material at the initiation of core-concrete interaction that is released during that interaction, and the fraction of the radionuclide inventory released during core-concrete interaction that is released from containment). The latent cancer fatality risk uncertainty is dominated by

12. Public Risk

accident frequency parameters (fire initiating event frequencies, diesel generator failure-to-run probability).

- For Grand Gulf, the uncertainty in early health effect parameters (early fatalities and individual early fatalities within 1 mile) is not dominated by any small set of parameters. Rather, it is accounted for by a number of parameters that determine the frequencies and radioactive release magnitudes of those events leading to early containment failure, such as the amount of hydrogen generated during the in-vessel portion of the accident progression, and the frequency of loss of off-site power. The uncertainties in the other risk measures are dominated by uncertainties in accident frequency parameters (including loss of offsite power frequency, diesel generator failure-to-start probability, diesel generator failure-to-run probability, and the probability that the batteries fail to deliver power when needed).

Impact of Emergency Response and Protective Action Guide Options

Sensitivity calculations were performed as a part of this study to assess the impacts of different emergency response and protective action guide options on estimates of risks for the five plants.

Emergency Response Options

In order to study the effects of emergency response options under severe accident conditions on public risk, the plants were analyzed using the following assumptions, and changes in the early fatality risk were calculated:

- Base Case: 99.5 percent evacuation from 0 to 10 miles
- Option 1: 100 percent evacuation from 0 to 10 miles
- Option 2: 0 percent evacuation with early relocation from high contamination areas
- Option 3: 100 percent sheltering
- Option 4: 100 percent evacuation from 0 to 5 miles and 100 percent sheltering from 5 to 10 miles

The last two options are used in the Zion plant analysis only. Results of the analyses are presented in Figure 12.11.

As discussed in Section 11.3, radionuclide release magnitudes associated with the early phase of an accident for Peach Bottom and Grand Gulf are typically smaller than those for the other three plants because of the mitigative effects of suppression pool scrubbing. The source term groups for Peach Bottom and Grand Gulf were typically found to have longer warning times than for the PWRs studied because the accident sequences developed more slowly. Further, Peach Bottom and Grand Gulf have very low surrounding population densities, which leads to shorter evacuation delays and higher evacuation speeds. The effect of all these considerations is that, for Peach Bottom and Grand Gulf, evacuation is more effective in reducing early fatality risk than for Surry, Sequoyah, and Zion.

For Surry and Sequoyah, the risk-dominant accident is the interfacing-system LOCA (the V sequence). This accident has a very short warning time, and, consequently, evacuation actions are not very effective. Also for Sequoyah, some high-consequence releases occur from containment failure at vessel breach; these releases are highly energetic and cause plume rise. This reduces early fatality risk, as is indicated in the case of Option 2 for Sequoyah; however, this also reduces the effectiveness of evacuation. Further details on emergency response options are provided in Chapter 11.

Protective Action Options

In this study an interdiction criterion of 4 rems (effective dose equivalent (EDE)) in 5 years has been used for groundshine and inhalation of resuspended radionuclides. Sensitivity calculations have been performed using the equivalent of the Reactor Safety Study (RSS) criterion, i.e., 25-rem EDE in 30 years. The impact of such an alternative criterion on mean latent cancer fatality risk is shown in Figure 12.12. As may be seen, the RSS criterion is less restrictive than the criterion used in this study, and the corresponding latent cancer fatalities using the RSS criterion are higher by 12 percent (for Grand Gulf) to 47 percent (for Peach Bottom).

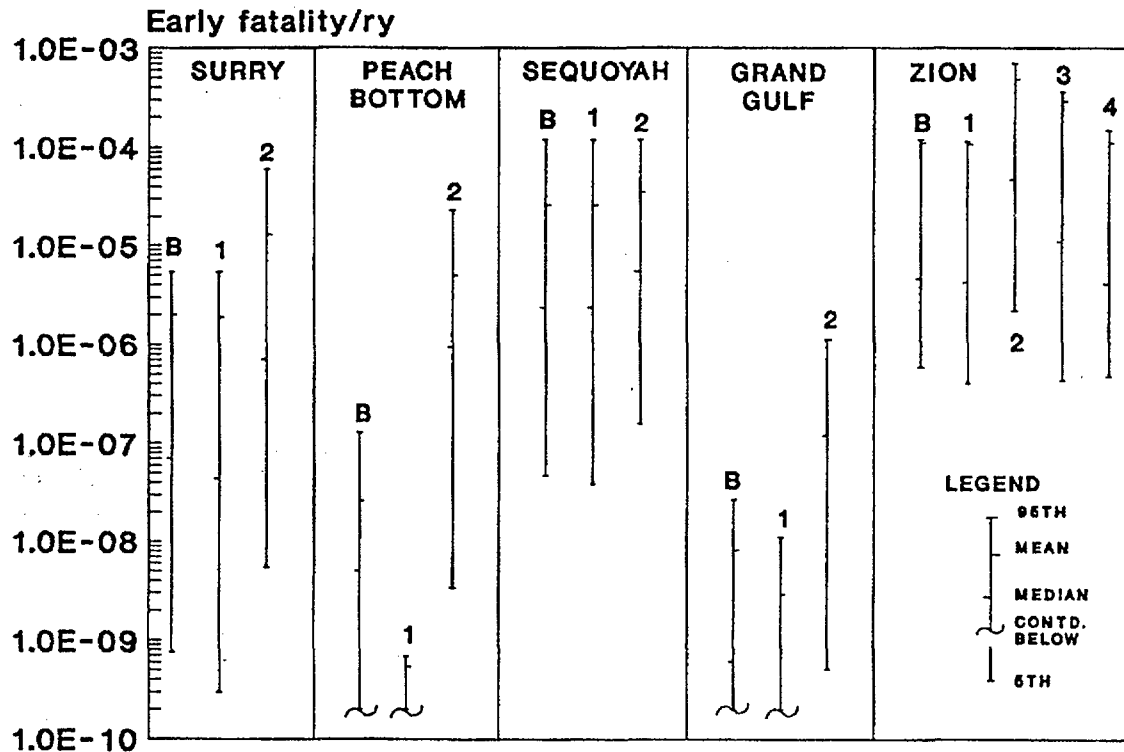
**BASE CASE (B)**

99.5% Evacuation from 0 to 10 miles

EMERGENCY RESPONSE OPTIONS (1 TO 4)

1. 100% Evacuation from 0 to 10 miles
2. 0% Evacuation with early relocation from high contamination areas
3. 100% Sheltering
4. 100% Evacuation from 0 to 5 miles, and 100% sheltering from 5 to 10 miles

Note: As discussed in Reference 12.9, estimated risks at or below $1E-7$ should be viewed with caution because of the potential impact of events not studied in the risk analyses.

Figure 12.11 Effects of emergency response assumptions on early fatality risks at all plants (internal events).

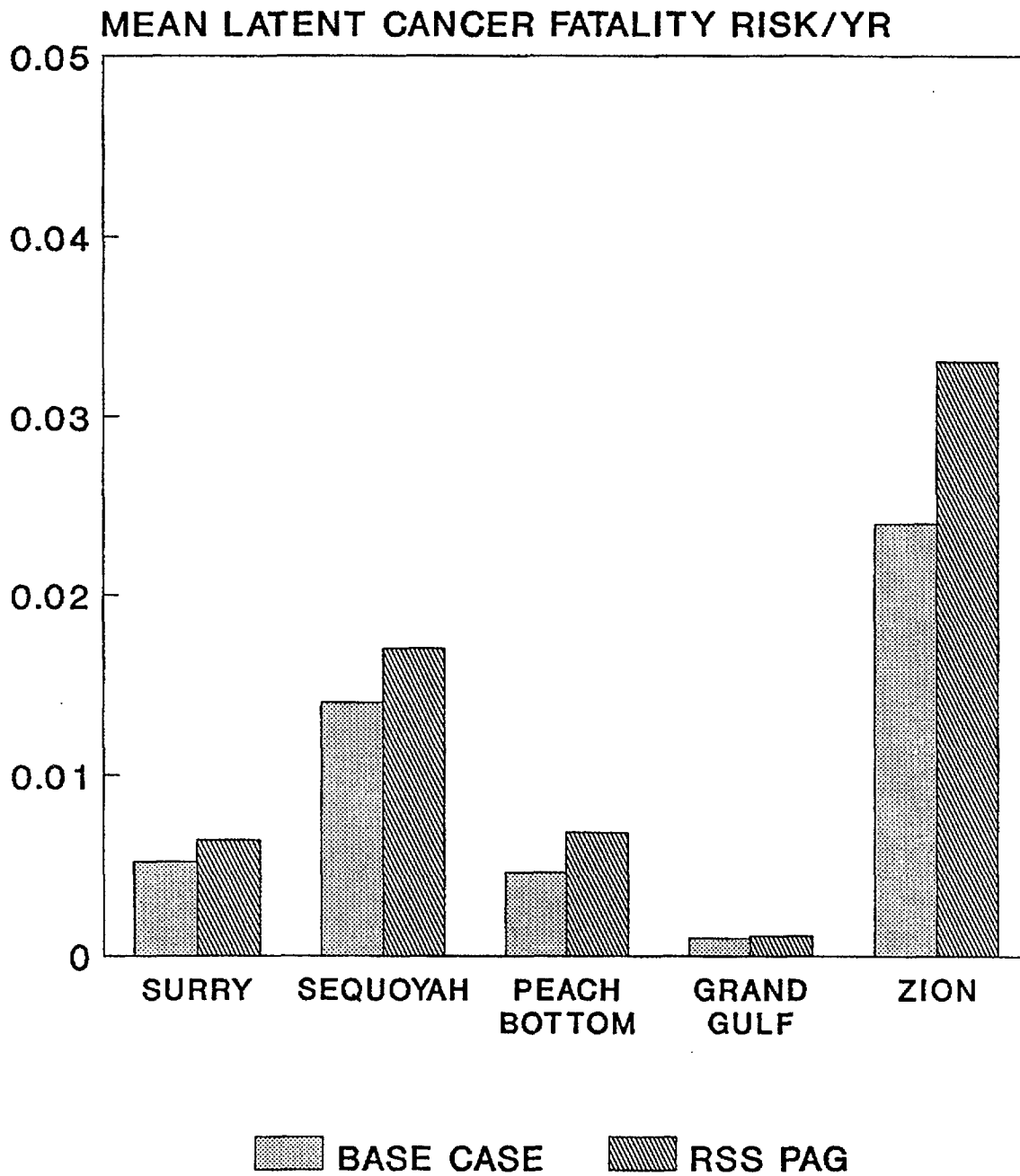

Figure 12.12 Effects of protective action assumptions on mean latent cancer fatality risks at all plants (internal events).

REFERENCES FOR CHAPTER 12

- 12.1 E. D. Gorham-Bergeron et al., "Evaluation of Severe Accident Risks: Methodology for the Accident Progression, Source Term, Consequence, Risk Integration, and Uncertainty Analyses," Sandia National Laboratories, NUREG/CR-4551, Vol. 1, Draft Revision 1, SAND86-1309, to be published.*
- 12.2 F. T. Harper et al., "Evaluation of Severe Accident Risks: Quantification of Major Input Parameters," Sandia National Laboratories, NUREG/CR-4551, Vol. 2, Revision 1, SAND86-1309, December 1990.
- 12.3 R. J. Breeding et al., "Evaluation of Severe Accident Risks: Surry Unit 1," Sandia National Laboratories, NUREG/CR-4551, Vol. 3, Revision 1, SAND86-1309, October 1990.
- 12.4 A. C. Payne, Jr., et al., "Evaluation of Severe Accident Risks: Peach Bottom Unit 2," Sandia National Laboratories, NUREG/CR-4551, Vol. 4, Draft Revision 1, SAND86-1309, to be published.*
- 12.5 J. J. Gregory et al., "Evaluation of Severe Accident Risks: Sequoyah Unit 1," Sandia National Laboratories, NUREG/CR-4551, Vol. 5, Revision 1, SAND86-1309, December 1990.
- 12.6 T. D. Brown et al., "Evaluation of Severe Accident Risks: Grand Gulf Unit 1," Sandia National Laboratories, NUREG/CR-4551, Vol. 6, Draft Revision 1, SAND86-1309, to be published.*
- 12.7 C. K. Park et al., "Evaluation of Severe Accident Risks: Zion Unit 1," Brookhaven National Laboratory, NUREG/CR-4551, Vol. 7, Draft Revision 1, BNL-NUREG-52029, to be published.*
- 12.8 USNRC, "Safety Goals for the Operation of Nuclear Power Plants; Policy Statement," *Federal Register*, Vol. 51, p. 30028, August 21, 1986.
- 12.9 H. J. C. Kouts et al., "Special Committee Review of the Nuclear Regulatory Commission's Severe Accident Risks Report (NUREG-1150)," NUREG-1420, August 1990.
- 12.10 USNRC, "Reactor Safety Study—An Assessment of Accident Risks in U.S. Commercial Nuclear Power Plants," WASH-1400 (NUREG-75/014), October 1975.

*Available in the NRC Public Document Room, 2120 L Street NW., Washington, DC.

13. NUREG-1150 AS A RESOURCE DOCUMENT

13.1 Introduction

NUREG-1150 is one element of the NRC's program to address severe accident issues. The entire program was discussed in a staff document entitled "Integration Plan for Closure of Severe Accident Issues" (SECY-88-147) (Ref. 13.1). NUREG-1150 is used to provide a snapshot of the state of the art of probabilistic risk analysis (PRA) technology, incorporating improvements since the issuance of the Reactor Safety Study (Ref. 13.2). This chapter discusses the results of NUREG-1150 (and its supporting contractor studies, Refs. 13.3 through 13.16) as a resource document and examines the extent to which information provided in the document can be applied in regulatory activities. This is accomplished by applying NUREG-1150 results and principles to selected regulatory issues to illustrate how the information and insights described in Chapters 3 through 12 of this document can be used in the regulatory process. The discussion will concentrate on technical issues although it is recognized that there are other issues (e.g., legal, procedural) that must be taken into account when making regulatory decisions.

This report includes an examination of the severe accident frequencies and risks and their associated uncertainties for five licensed nuclear power plants and uses the latest source term information available from both the NRC and its contractors and the nuclear industry. The information in the report provides a valuable resource and insights to the various elements of the severe accident integration plan. The information provided and how it will be used include the following:

- Probabilistic models of the spectrum of possible accident sequences, containment events, and offsite consequences of severe accidents for use in:
 - Development of guidance for the individual plant examinations of internally and externally initiated accidents;
 - Accident management strategies;
 - Analysis of the need and appropriate means for improving containment performance under severe accident conditions;

- Characterization of the importance of plant operational features and areas potentially requiring improvement;
- Analysis of alternative safety goal implementation strategies; and
- Emergency preparedness and consequences.
- Data on the major contributing factors to risk and the uncertainty in risk for use in:
 - Prioritization of research;
 - Prioritization of generic issues; and
 - Use of PRA in inspection.

In the following sections, these uses will be discussed in greater detail, using examples based on the risk analysis results discussed in previous chapters.

13.2 Probabilistic Models of Accident Sequences

NUREG-1150 identifies the dominant accident sequences and plant features contributing significantly to risk at a given plant as well as the plant models used in the study. The plant models and results underlying the report can be used to support the development of staff guidance on licensee-performed studies (individual plant examinations, accident management studies) and staff work in other areas related to severe accidents (e.g., improving containment performance under severe accident conditions). Such uses are discussed in greater detail in the following sections.

13.2.1 Guidance for Individual Plant Examinations

Plant-specific PRAs have yielded valuable perspectives on unique plant vulnerabilities. The NRC and the nuclear industry both have considerable experience with plant-specific PRAs. This experience, coupled with the interactions of NRC and the nuclear industry on severe accident issues, have resulted in the Commission's formulating an integrated systematic approach to an examination of each nuclear power plant now operating or under construction for possible significant risk contributions (sometimes called "outliers") that might be plant specific and might be

missed without a systematic approach. In November 1988, the NRC requested (by generic letter) that each licensed nuclear power plant perform an individual plant examination (IPE) to identify any plant-specific vulnerabilities to severe accidents (Ref. 13.17). The technical data generated in the course of preparing NUREG-1150 on severe accident frequencies, risks, and important uncertainties were used in developing the analysis requirements described in the IPE generic letter and the supplemental guidance on the IPE external-event analysis (Ref. 13.18).^{*} These studies will also aid the staff in evaluating individual submittals, assessing the adequacy of the identification of plant-specific vulnerabilities by the licensee, and evaluating any associated potential plant modifications.

The extent to which NUREG-1150 results are applicable to different classes of reactors or to operating U.S. light-water reactors as a group is illustrated in Table 13.1. The generic insights presented in NUREG-1150 are indicative of items that may be applicable within a class of plants. This includes the identification of possible vulnerabilities that may exist in plants of similar design. These insights cannot be assumed to apply to a given plant without consideration of plant design and operational practices because of the design differences that exist in U.S. plants, particularly those involving ancillary support systems (e.g., ac power, component cooling water) for the engineered safety features and differences in details of containment design.

For some issues, the state of knowledge is very limited, and it is not possible to identify plant-specific features that may influence the issue because sensitivity analyses have not been performed. In other cases, the methodology is broadly applicable, but the results are highly plant specific. In spite of the plant-specific nature of many of the results, much can be learned from one plant that can be applied to another. Example types of generic applicability are presented in Table 13.1.

The NUREG-1150 methods refer not only to the analytical techniques employed but the general structure and framework upon which the analyses were conducted. These methods include the uncertainty analysis, expert elicitation methods, accident progression event tree analysis, and source term modeling. The general approaches adopted

^{*}In addition, NUREG-1150 provides extensive and detailed analyses of five nuclear power plants and thus offers licensees of those plants an opportunity to use these studies in developing their IPEs and submitting them on an expedited basis.

in these analysis procedures are not plant specific and are therefore adaptable to other plant analyses.

As noted above, plant-specific PRAs have yielded valuable perspectives on unique plant vulnerabilities. These perspectives are, in general, not directly applicable to other plants, although they provide useful information to the study of plants of similar NSSS (nuclear steam supply system) and containment design. At the present time, the principal contributors to the likelihood of a core damage accident at boiling water reactors (BWRs) include sequences related to station blackout or anticipated transients without scram (ATWS). Accident sequences making important contributions to the frequency of core damage accidents at pressurized water reactors (PWRs) include those initiated by a variety of electrical power system disturbances (loss of a single ac bus, which initiates a transient; loss of offsite portions of the equipment needed to respond to the transient; loss of offsite power; and complete station blackout), small loss-of-coolant accidents (LOCAs), loss of coolant support systems such as the component cooling water system, ATWS, and interfacing-system LOCAs or steam generator tube ruptures in which reactor coolant is released outside the containment boundary. All have the potential for being important at PWRs.

NUREG-1150 provides a wide spectrum of phenomenological and operational data (much of it of a very detailed nature). For example, information on hydrogen generation has been compiled from experimental and calculational results as well as interpretations of these data by experts. This data base provides an important source of information that may be used for NSSS containment types similar to those studied here but is somewhat less applicable for different NSSS containment types. The operational data base includes component failure rates, maintenance times, and initiating-event frequency data. Much of these data are generic in nature and thus applicable for selected classes of plants.

The analyses presented in Chapters 3 through 7, when combined with the information gained from earlier PRA work sponsored by both NRC (e.g., Ref. 13.19) and utilities, make it clear that the quantitative results (core damage frequencies and risk results) calculated for internal and external initiators cannot be considered applicable to another plant, even if the plant has a similar NSSS design and the same architect-engineer was involved in the design of the balance of plant.

Table 13.1 Utility of NUREG-1150 PRA process to other plant studies.

| Example Results | Applicability | |
|---|-----------------|------------------|
| | Class of Plants | Plant Population |
| 1. Methods (e.g., uncertainty, elicitation, event tree/fault tree) | high | high |
| 2. General perspectives (e.g., principal contributors to core damage frequency and risk) | medium | low |
| 3. Supporting data base on design features, operational characteristics, and phenomenology (e.g., hydrogen generation in core damage accidents, operational data) | high | medium |
| 4. Quantitative results (e.g., core damage frequency, containment performance, risk) | low | low |

Site-specific requirements and differing utility requirements often lead to significant differences in support system designs (e.g., ac power, dc power, service water) that can significantly influence the response of the plant to various potential accident-initiating events. Further, different operational practices, including maintenance activities and techniques for monitoring the operational reliability of components or systems can have a significant influence on the likelihood or severity of an accident.

13.2.2 Guidance for Accident Management Strategies

Certain preparatory and recovery measures can be taken by the plant operating and technical staff that could prevent or significantly mitigate the consequences of a severe accident. Broadly defined, such "accident management" includes the measures taken by the plant staff to (1) prevent core damage, (2) terminate the progress of core damage if it begins and retain the core within the reactor vessel, (3) maintain containment integrity as long as possible, and finally (4) minimize the consequences of offsite releases. In addition, accident management includes certain measures taken before the occurrence of an event (e.g., improved training for severe accidents, hardware or procedure modifications) to facilitate implementation of accident management strategies. With all these factors taken together, accident management is viewed as an important means of achieving and maintaining a low risk from severe accidents.

Under the staff program, accident management programs will be developed and implemented by

licensees. The NRC will focus on developing the regulatory framework under which the industry programs will be developed and implemented, as well as providing an independent assessment of licensee-proposed accident management capabilities and strategies. NUREG-1150 has been used by the NRC staff to support the development of the accident management program. NUREG-1150 methods provide a methodological framework that can be used to evaluate particular strategies, and the current results provide some insights into the efficacy of strategies in place or that might be considered at the NUREG-1150 plants. Thus, the NUREG-1150 methods and results will support a staff review of licensee accident management submittals.

PRA information has been used in the past to influence accident management strategies; however, the methods used in NUREG-1150 can bring added depth and breadth to the process, along with a detailed, explicit treatment of uncertainties. The integrated nature of the methods is particularly important, since actions taken during early parts of an accident can affect later accident progression and offsite consequences. For example, an accident management strategy at a BWR may involve opening a containment vent. This action can affect such things as the system response and core damage frequency, the retention of radioactive material within the containment, and the timing of radionuclide releases (which impacts evacuation strategies). It is possible that actions to reduce the core damage frequency can yield accident sequences of lower frequency but with much higher consequences. All these factors need to be considered in concert when developing

13. Resource Document

appropriate venting strategies. The treatment of uncertainties is another key aspect of accident management. Generally, procedures are developed based on "most likely" or "expected" outcomes. For severe accidents, the outcomes are particularly uncertain. PRA models and results, such as those produced in the accident progression event trees, can identify possible alternative outcomes for important accident sequences. By making this information available to operators and response teams, unexpected events can be recognized when they occur, and a more flexible approach to severe accidents can be developed. The recent trend toward symptom-based, as opposed to event-based, procedures is consistent with this need for flexibility.

To demonstrate the potential benefits of an accident management program, some example calculations were performed, as documented in Reference 13.20. For this initial demonstration, these calculations were limited to the internal-event accident sequence portion of the analysis. Further, the numerical results presented are "point estimates" of the core damage frequency as opposed to mean frequency estimates. Selected examples from the initial analysis are presented below.

Effect of Firewater System at Grand Gulf

The first NUREG-1150 analysis of the Grand Gulf plant (Ref. 13.21) did not credit use of the firewater system for emergency coolant injection because of the unavailability of operating procedures for its use in this mode and the difficulties in physically configuring its operation. However, since that time, the licensee has made significant system and procedural modifications. As a result, the firewater system at Grand Gulf can now be used as a backup source of low-pressure coolant injection to the reactor vessel. The system would be used for long-term accident sequences, i.e., where makeup water was provided by other injection systems for several hours before their subsequent failure. The firewater system primarily aids the plant during station blackout conditions and is considered a last resort effort.

An examination has been made of the benefit of these licensee modifications to the Grand Gulf plant. As shown in Figure 13.1, these analyses showed that the total core damage frequency was reduced from $4E-6$ to $2E-6$ per reactor year because of these changes.

Effect of Feed and Bleed on Core Damage Frequency at Surry

The NUREG-1150 analysis for Surry includes the use of feed and bleed cooling for those sequences in which all feedwater to the steam generators is lost (thus causing their loss as heat removal systems). Feed and bleed cooling restores heat removal from the core using high-pressure injection (HPI) to inject into the reactor vessel and the power-operated relief valves (PORVs) on the pressurizer to release steam and regulate reactor coolant system pressure.

An examination has been made to determine to what extent feed and bleed cooling decreases core damage frequency at Surry. The current Surry model includes two basic events representing failure modes for feed and bleed cooling in the event of a loss of all feedwater. These modes are: operator failure to initiate high-pressure injection and operator failure to properly operate the PORVs. In order to examine the impact of feed and bleed cooling, both basic events were assumed to always occur. As shown in Figure 13.1, the resulting total core damage frequency for Surry (if feed and bleed cooling were not available) then increases by roughly a factor of 1.3. That is, the availability of the feed and bleed core cooling option in the Surry design and operation is estimated to reduce core damage frequency from $4E-5$ to $3E-5$ per reactor year.

Gas Turbine Generator Recovery Action at Surry

The present NUREG-1150 modeling and analysis of the Surry plant have not considered the benefits of using onsite gas turbine generators for recovery in the event of station blackout accidents. Both a 25 MW and a 16 MW gas turbine generator are available to provide emergency ac power to safety-related and non-safety-related equipment. These generators were not included in the analysis because, as currently configured, they would not be available to mitigate important accident sequences.

An examination has been made of the effect on core damage frequency at Surry of including the gas turbine generators as a means of recovery from station blackout sequences. To give credit for the addition of one generator for emergency ac power, it is assumed that Surry plant personnel have the authority to start the gas turbines when required and that 1 hour is required to start the gas turbines and energize the safety buses. In the analysis, the gas turbines were assumed to be available 90 percent of the time.

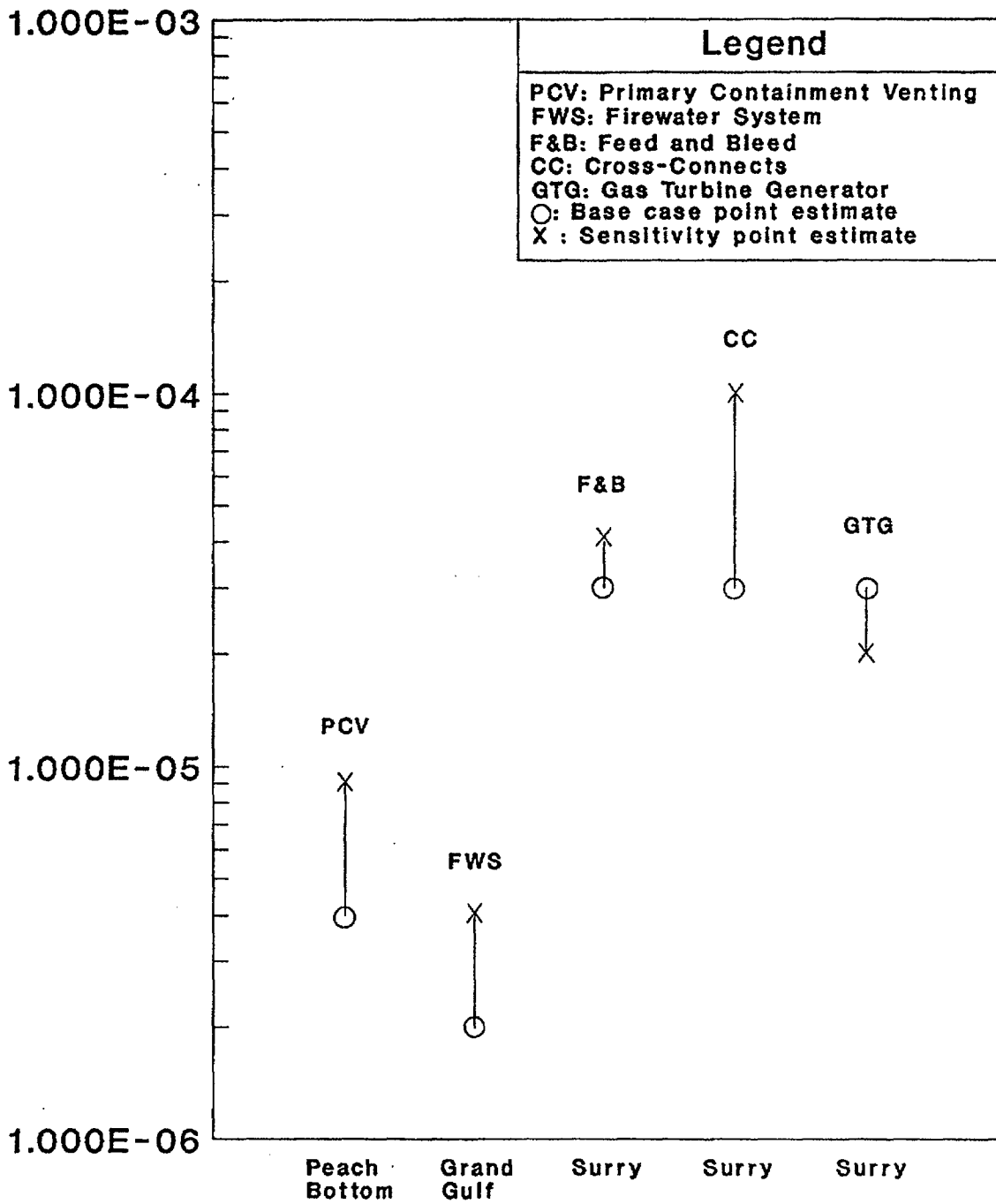

Figure 13.1 Benefits of accident management strategies.

13. Resource Document

The use of the onsite gas turbine was estimated to reduce core damage frequency from $3E-5$ to $2E-5$ per reactor year.

High-Pressure Injection and Auxiliary Feedwater Crossconnects at Surry

The Surry Unit 1 plant is configured to recover from loss of either the high-pressure injection (HPI) system or the auxiliary feedwater (AFW) system by operator-initiated crossconnection to the analogous system at Unit 2. While these actions provide added redundancy to these systems, new failure modes (e.g., flow diversion pathways) that were included in the modeling process for Surry have been created. The alignment of the Unit 1 and Unit 2 HPI and AFW systems for crossconnect injection is modeled as a recovery action.

Analysis of the importance of crossconnect injection at Surry includes two parts. First, credit for crossconnect injection was removed from all applicable dominant sequences, which were then re-quantified. Second, sequences that were previously screened out of the analysis were checked to determine if they would become dominant in the absence of crossconnect injection. As shown in Figure 13.1, the point estimate of the total core damage frequency without crossconnects is $1E-4$, compared to the value of $3E-5$ for internally initiated events in the base case.

Primary Containment Venting at Peach Bottom

The primary containment venting (PCV) system at Peach Bottom is used to prevent primary containment overpressurization during accident sequences in which all containment heat removal is lost. Most sequences of this type involve failure of the residual heat removal systems. Because of the existence of this venting capability, no such accident sequences appeared as dominant in the NUREG-1150 analysis for Peach Bottom.

The effect of the PCV system on the core damage frequency at Peach Bottom was determined by examining the sequences screened out in the NUREG-1150 analysis that included the PCV system as an event (primarily the sequences involving loss of containment heat removal). Credit for the PCV system was removed from these sequences, which were then summed and added to the current point estimate of the core damage frequency. As shown in Figure 13.1, this results in a point estimate of the Peach Bottom core damage fre-

quency without containment venting of $9E-6$, about a factor of 2.6 increase over the NUREG-1150 value of $4E-6$.

13.2.3 Improving Containment Performance

The NRC has performed an assessment of the need to improve the capabilities of containment structures to withstand severe accidents (Ref. 13.1). Staff efforts focused initially on BWR plants with a Mark I containment, followed by the review of other containment types. This program was intended to examine potential enhanced plant and containment capabilities and procedures with regard to severe accident mitigation. NUREG-1150 provided information that served to focus attention on areas where potential containment performance improvements might be realized. NUREG-1150 as well as other recent risk studies indicate that BWR Mark I risk is dominated by station blackout and anticipated transient without scram (ATWS) accident sequences. NUREG-1150 further provided a model for and showed the benefit of a hardened vent for Peach Bottom (discussed above and displayed in Figure 13.1). The staff is currently pursuing regulatory actions to require hardened vents in all Mark I plants, using NUREG-1150 and other PRAs in the cost-benefit analysis.

The NUREG-1150 accident progression analysis models were used by the staff and its contractors in the evaluation of possible containment improvements for the PWR ice condenser and BWR Mark III designs. The result of the staff reviews of these designs (and all others except the Mark I) was that potential improvements would best be pursued as part of the individual plant examination process (discussed in Section 13.2.1).

13.2.4 Determining Important Plant Operational Features

NUREG-1150 will provide a source of information for investigating the importance of operational safety issues that may arise during day-to-day plant operations. The NUREG-1150 models, methods, and results have already been used to analyze the importance of venting of the suppression pool, the importance of keeping the PORVs and atmospheric dump valves unblocked, the importance of operational characteristics of the ice condenser containment design, the importance of operator recovery during an accident sequence, and the importance of crossties between systems. These operational and system characteristics, as well as many others, are described in detail in Chapters 3 through 7. For example, characteristics of the Surry plant design and operation that

have been found to be important include crossties between units, diesel generators, reactor coolant pump seals, battery capacity, capability for feed and bleed core cooling, subatmospheric containment operation, post-accident heat removal system, and reactor cavity design.

13.2.5 Alternative Safety Goal Implementation Strategies

On August 21, 1986, the Commission published a Policy Statement on Safety Goals for the Operation of Nuclear Power Plants (Ref. 13.22). In this statement, the Commission established two qualitative safety goals supported by two risk-based quantitative objectives that deal with individual and societal risks posed by nuclear power plant operation. The objective of the policy statement was to establish goals that broadly define an acceptable level of radiological risk that might be imposed on the public as a result of nuclear power plant operation.

The Commission recognized that the safety goals could provide a useful tool by which the adequacy of regulations or regulatory decisions regarding changes to the regulations could be judged. Safety goals could be of benefit also in the much more difficult task of assessing whether existing plants that have been designed, constructed, and operated to comply with past and current regulations conform adequately with the intent of the safety goal policy.

The models and results of NUREG-1150 can be used in a number of ways in the NRC staff's analysis and implementation of safety goal policy. For example, the five plants studied for this report have been compared with the two quantitative health objectives, as shown in Figure 13.2 for internal initiators. Figure 13.3 compares Surry and Peach Bottom with the quantitative health objectives for fire initiators. As may be seen, the present risk estimates for these five plants (considering internally initiated accidents) and for the Surry and Peach Bottom plants (considering fire initiators) fall beneath the quantitative health objective risk goals. In addition, however, it may be seen that the risk estimates among the five plants vary considerably. An analysis of the plant design and operational differences that cause this variability can provide valuable information to the staff in its consideration of the balance of the present set of regulations and the areas of regulation that could most benefit from improvement.

The staff has reviewed the NUREG-1150 results at a broad level to determine the causes of the variability among plant risks shown in Figure 13.2.

A number of design, operational, and siting factors are important to this measure of plant risk and determine the relative location of a specific plant's risk range in comparison with other plants and with the safety goal. At a general level, core damage frequency, containment and source term performance, and surrounding population demographics all can affect the risk range. Thus, using the Surry plant as an example, the combination of a relatively low core damage frequency, relatively good containment performance, and a low population density act to ensure with a high probability that the risk is below the safety goal.

The NUREG-1150 results can also be used to support the analysis of alternative safety goal implementation approaches. One subject of discussion in the staff's work is the need for a supplemental definition of containment performance in severe accidents using the probability of a large release as a measure. An acceptable frequency for such a release was defined as $1E-6$ per reactor year. A potential definition of a large release is one that can cause one or more early fatalities.* The present NUREG-1150 risk analyses have been evaluated to provide the frequency of such a release, as shown in Figure 13.4. The mean large release probabilities are below $1E-6$ per reactor year. Further staff work in assessing alternative definitions is planned as part of the safety goal implementation program, and it is expected that NUREG-1150 methods and results will be used.

13.2.6 Effect of Emergency Preparedness on Consequence Estimates

NUREG-1150 provides information for developing protective action strategies that could be followed near a nuclear power plant in case of a severe accident. In developing strategies, consideration must be given to several types of protective actions, such as sheltering, evacuation, and relocation and various combinations. These strategies are influenced by the types of severe accidents that might occur at a nuclear power plant, their frequency of occurrence, and the radioactive release expected to result from each accident type as well as by the topography, weather, population density, and other site-specific characteristics.

NUREG-1150 provides assessments of a broad spectrum of potential core damage accidents that could occur at a nuclear power plant. These assessments permit the evaluation of hypothetical

*The Commission has now indicated that this is not an appropriate definition and has asked the staff to review and propose an alternative definition.

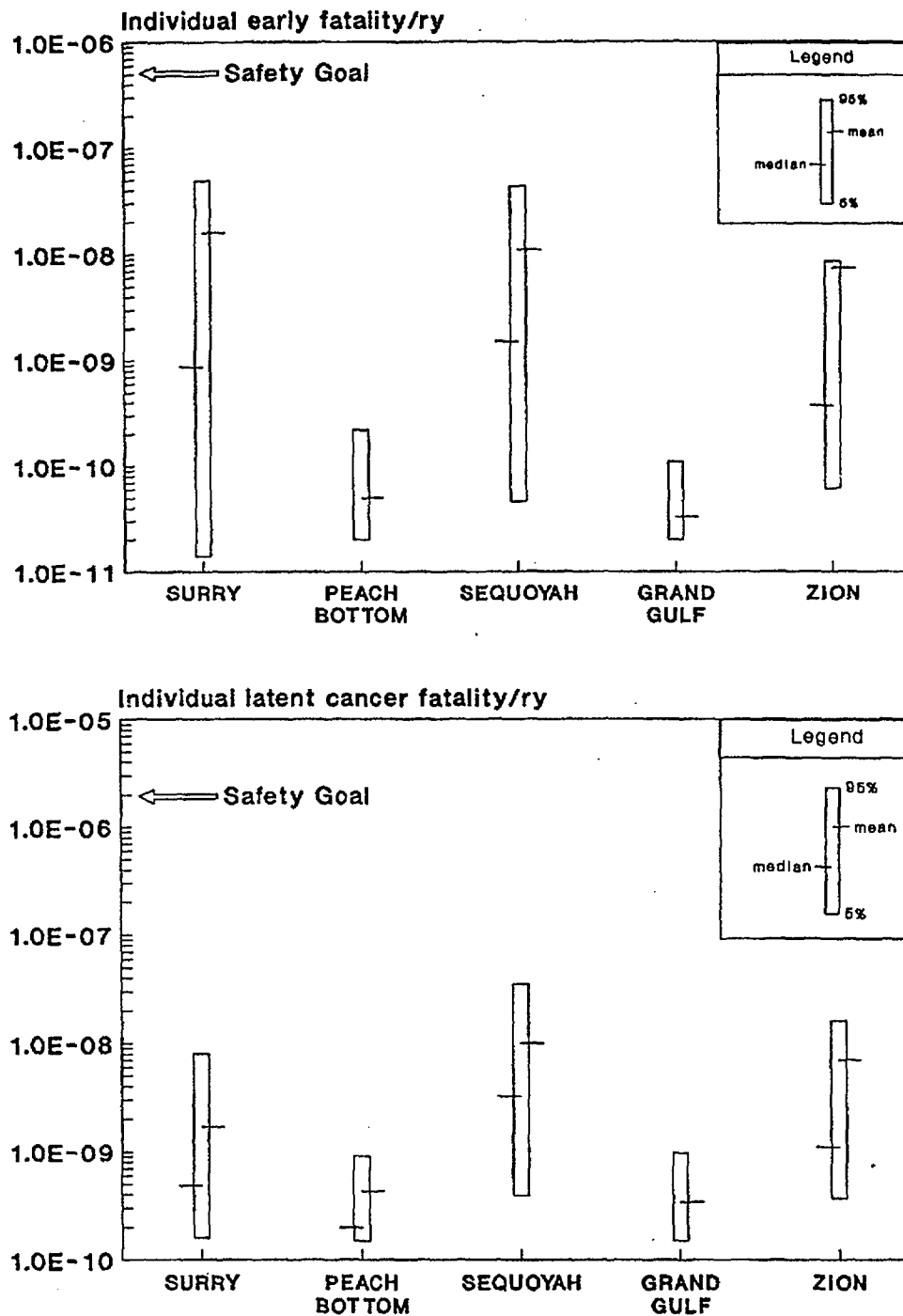

Note: As discussed in Reference 13.23, estimated risks at or below 1E-7 per reactor year should be viewed with caution because of the potential impact of events not studied in the risk analyses.

Figure 13.2 Comparison of individual early and latent cancer fatality risks at all plants (internal initiators).

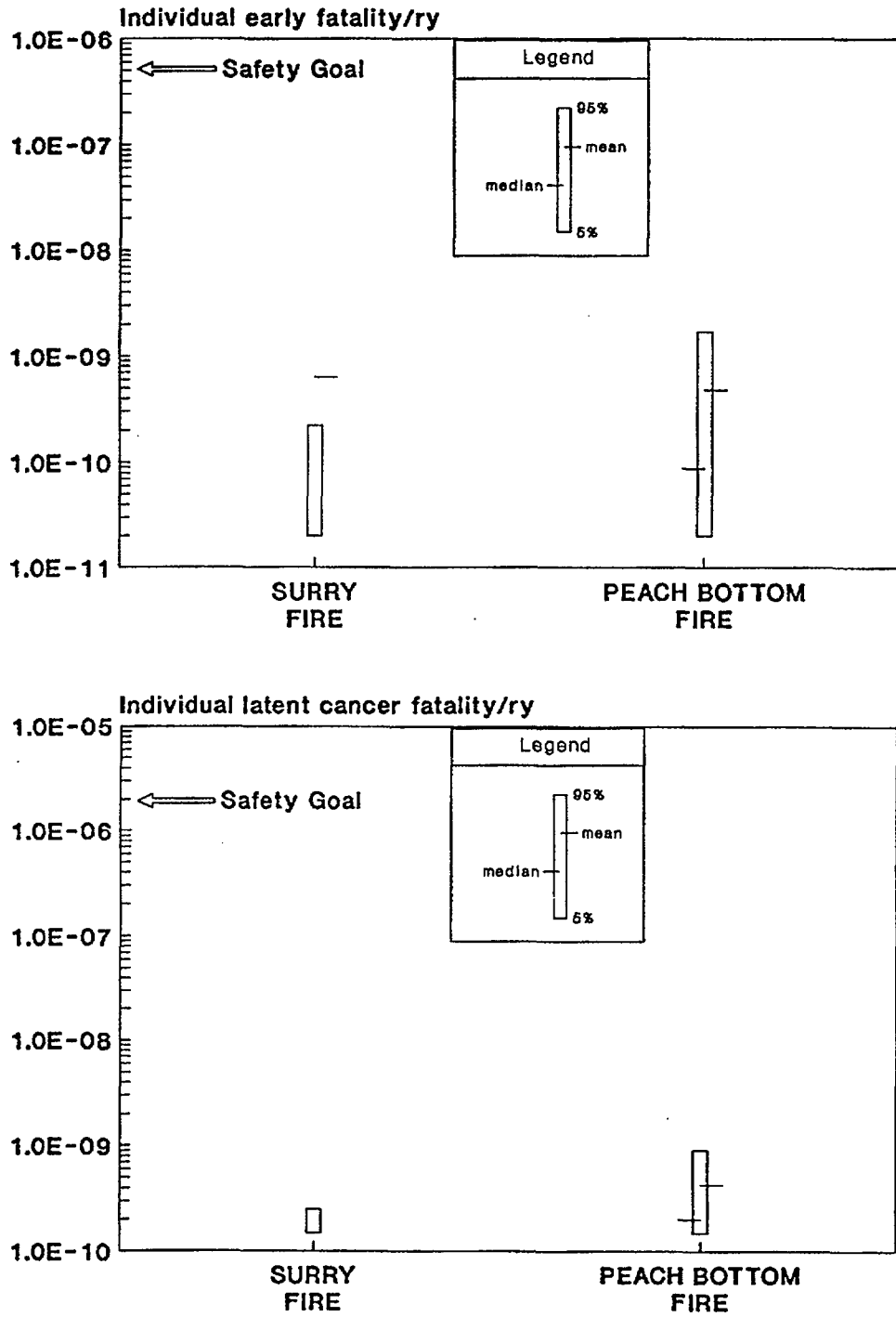

Note: As discussed in Reference 13.23, estimated risks at or below 1E-7 per reactor year should be viewed with caution because of the potential impact of events not studied in the risk analyses.

Figure 13.3 Comparison of individual early and latent cancer fatality risks at Surry and Peach Bottom (fire initiators).

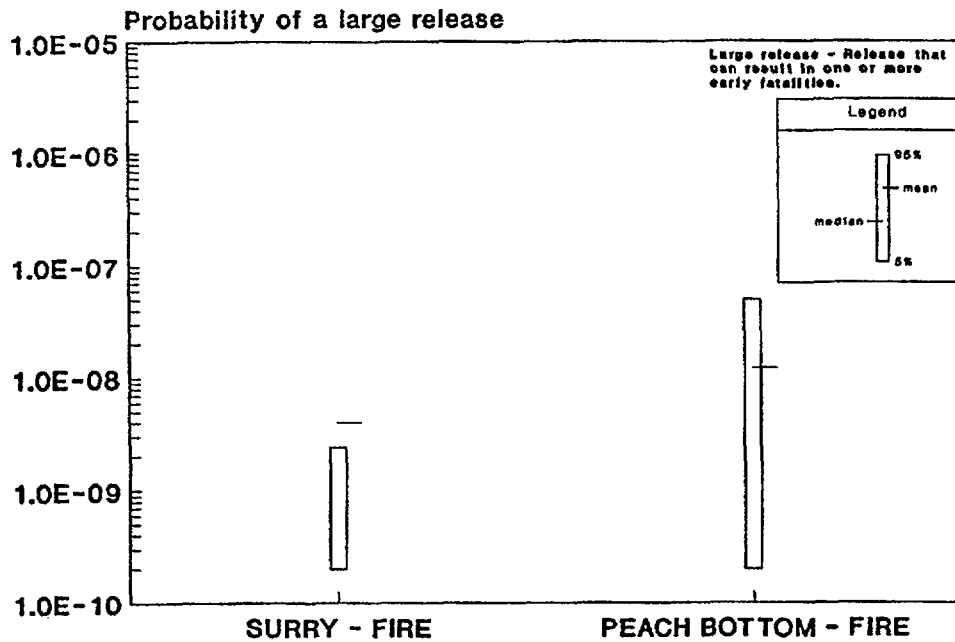
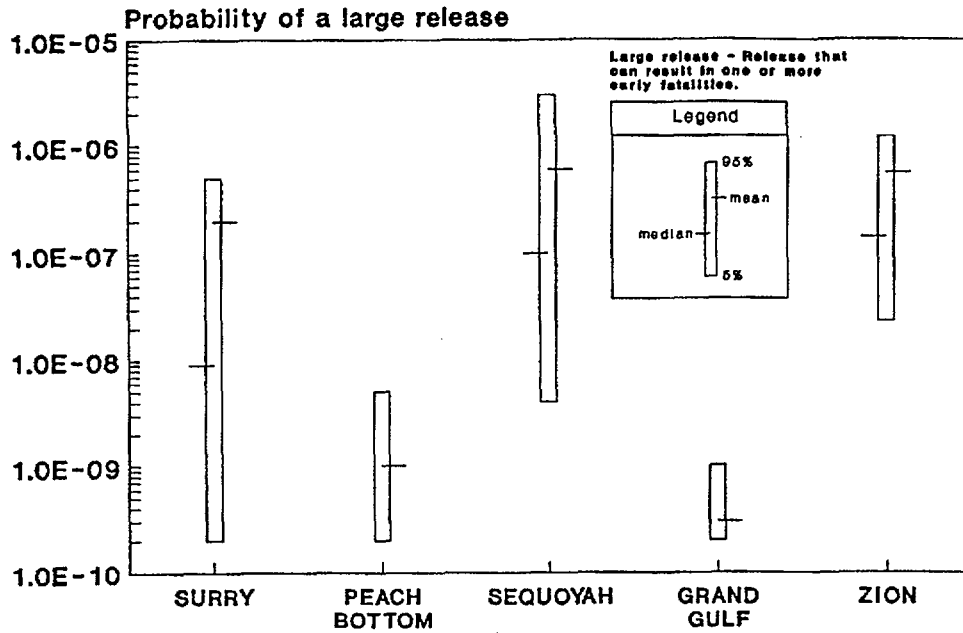

Note: As discussed in Reference 13.23, estimated risks at or below 1E-7 per reactor year should be viewed with caution because of the potential impact of events not studied in the risk analyses.

Figure 13.4 Frequency of one or more early fatalities.

dose savings for a spectrum of accidents and provide a means for evaluating potential reduction in early severe health effects (injuries and fatalities) in the event of an accident by implementing emergency response strategies.

The most important considerations in establishing emergency preparedness strategies are the warning times before release to initiate the emergency response and magnitude of the release of the radioactive material to the environment. The warning time and magnitude of radioactive release are in turn strongly influenced by the time and size of containment failure or bypass. If the containment fails early, the radioactive release is generally larger and more difficult to predict than if the containment fails late.

To evaluate the effectiveness of various protective actions, the conditional probabilities of acute red bone marrow doses exceeding 200 rems and 50 rems were calculated for several possible actions, using Zion plant source terms as examples. Doses were calculated on the plume centerline for various distances from the plant. The actions evaluated are:

- Normal activity—assumed that no protective actions were taken during the release but assumed that people were relocated within 6 hours of plume arrival.
- Home sheltering—sheltering in a single family home (see Table 11.5 for a definition of sheltering). The penetration fractions for groundshine and cloudshine were representative of masonry houses without basements as well as wood frame houses with basements. Indoor protection for inhalation of radionuclides was assumed. People were relocated from the shelter mode within 6 hours of plume arrival.
- Large building shelter—sheltering in a large building, for example, an office building, hospital, apartment building, or school. Indoor protection for inhalation of radionuclides was assumed. People were relocated from the shelter mode within 6 hours of plume arrival.
- Evacuation—doses were calculated for people starting to travel at the time of release, 1 hour before start of release, and 1 hour after start of release. An evacuation speed of 2.5 mph was assumed.

Figure 13.5 shows the conditional probabilities of exceeding a 50-rem and a 200-rem red bone mar-

row dose for the various possible response modes assuming an early containment failure at Zion with source term magnitudes varying from low to high. Figure 13.6 shows similar results for a late containment failure at Zion.

Use of the above assumptions indicates that if a large release occurs (Fig. 13.5), there is a large probability of doses exceeding 200 rems within 1 to 2 miles from the reactor. Sheltering does not significantly lower this probability. Thus, if a large release can occur, it is prudent to consider prompt evacuation prior to the start of the release.

At 3 miles and beyond, it is possible to avoid doses exceeding 200 rems by sheltering in large buildings even if a large release were to occur. Thus, people in large buildings such as hospitals would not necessarily have to be immediately evacuated, but could shelter instead. Of course, further reductions in dose are possible by evacuation.

At 10 miles, no protective actions except relocation would be necessary to avoid 200-rem doses. Sheltering in large buildings or evacuation prior to release would probably keep doses below 50 rems.

13.3 Major Factors Contributing to Risk

NUREG-1150 results can be used to identify dominant plant risk contributors and associated uncertainties. A discussion of these dominant risk contributors is found in Chapters 3 through 8 and Chapter 12. This section focuses on the use in guiding research, generic issue resolution, and inspection programs.

Because of its integrated nature, discussion of uncertainties, and reliance on more realistic assessments, PRA-based information found in NUREG-1150 and its supporting documents can be used to guide and focus a wide spectrum of activities designed to improve the state of knowledge regarding the safety of individual nuclear power plants, as well as that of the nuclear industry as a whole. The resources of both the NRC and the industry are limited, and the application of PRA techniques and subsequent insights provides an important tool to aid the decisionmaker in effectively allocating these resources.

The nature of the many decisions necessary to allocate regulatory resources does not require great precision in PRA results. For example, in assigning priorities to research or efforts to resolve generic safety issues, it is sufficient to use broad

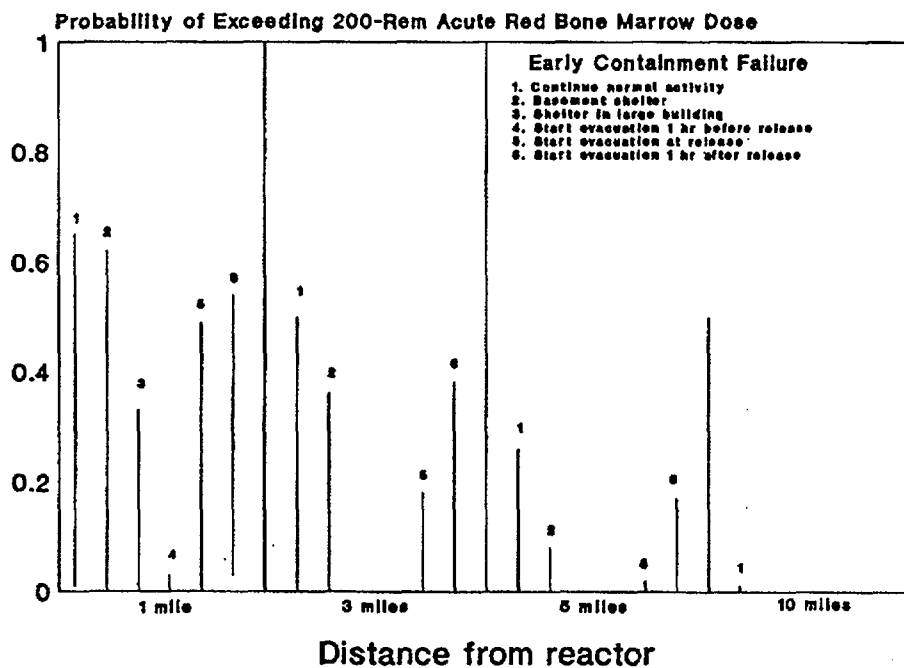
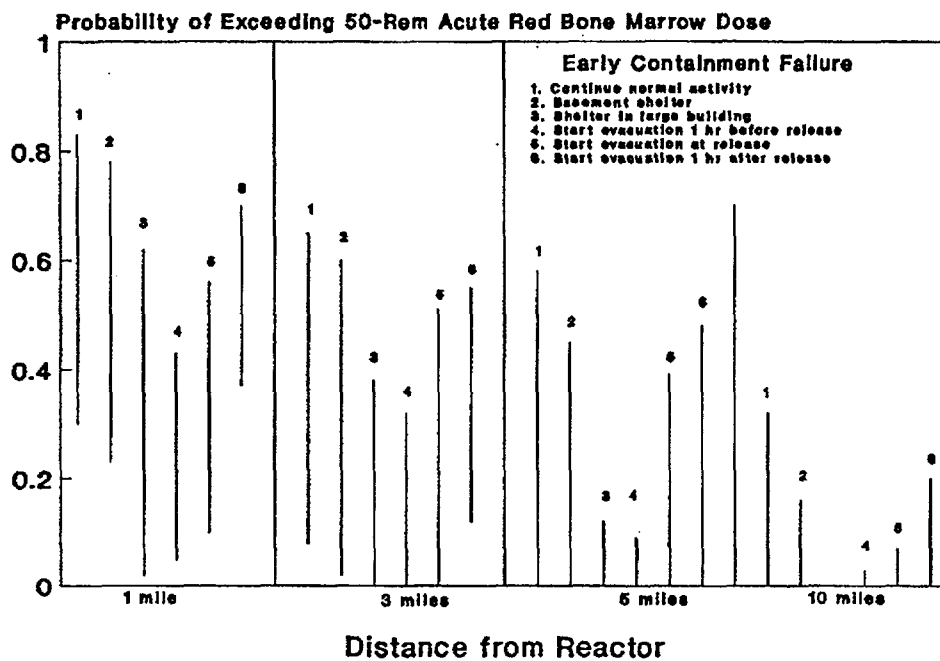

Figure 13.5 Relative effectiveness of emergency response actions assuming early containment failure with high and low source terms.

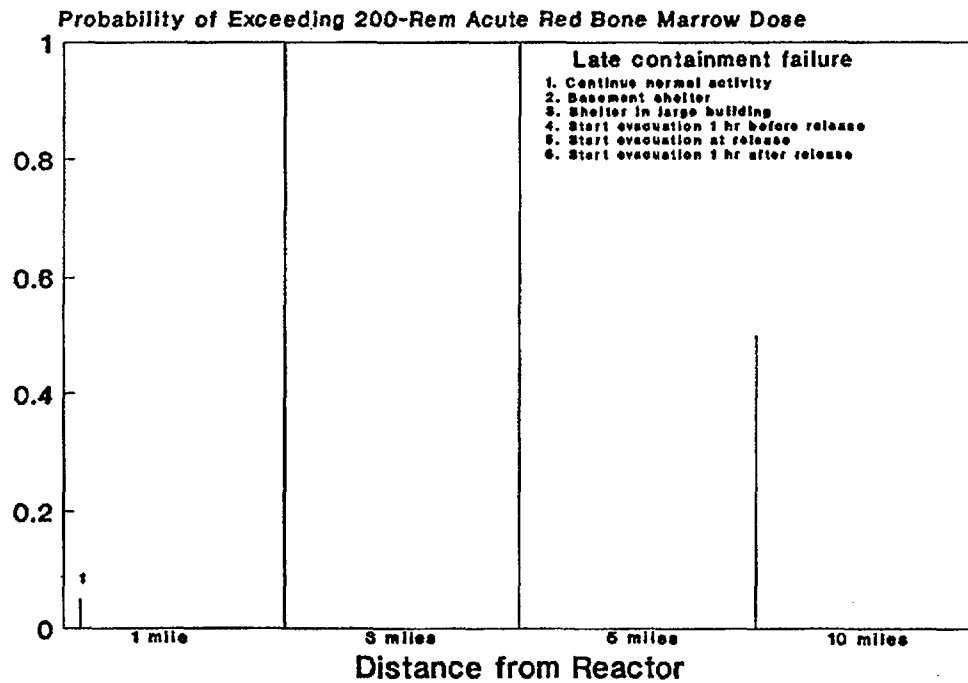
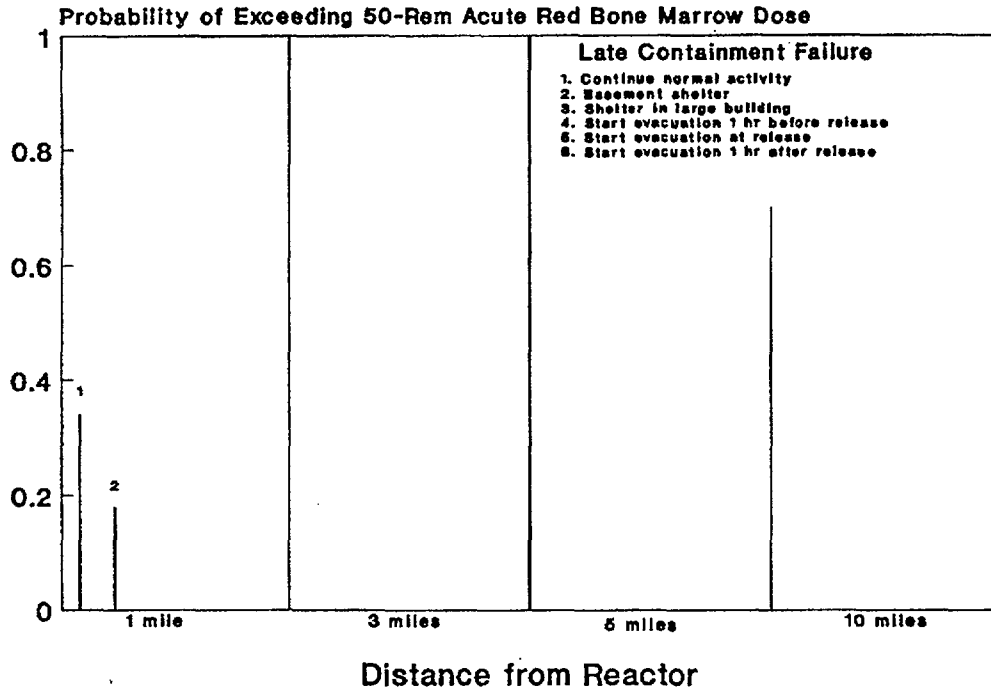

Figure 13.6 Relative effectiveness of emergency response actions assuming late containment failure with high and low source terms.

13. Resource Document

categories of risk impact (e.g., high, medium, and low) (Ref. 13.24). In a similar manner, information from PRAs can be used to guide the allocation of resources in inspection and enforcement programs (see Section 13.3.3).

13.3.1 Reactor Research

As noted earlier, the nature of the decisions necessary to allocate resources does not require great precision in PRA results. In prioritizing research efforts, it is sufficient to use broad categories of risk impact (e.g., high, medium, and low). A given issue can be evaluated in terms of the number of plants affected, the risk impacts on each plant, the effect of modifications in reducing the risk, and the effect of additional knowledge on improving the prediction of plant risk or severe core damage frequency or on reducing or defining more clearly the associated uncertainties. These generic measures of significance, combined appropriately with other information (e.g., cost of resolving the issue) can be used to evaluate the issue under consideration.

13.3.2 Prioritization of Generic Issues

The NRC has been setting priorities for generic safety issues for several years using PRA as one informational input (Ref. 13.25). In prioritizing efforts to resolve generic safety issues, it is sufficient to use broad categories of risk impact (e.g., high, medium, and low) in which only order-of-magnitude variations are considered important. The reasoning is that a potential safety issue would not be dismissed unless it were clearly of low risk. Thus, one or more completed PRA studies can often be selected as surrogates for the purpose of assigning such priorities, even though they clearly do not fully represent the characteristics of some plants, provided the nature of the difference is reasonably understood and can be qualitatively evaluated.

As with any priority-assignment method, the final results must be tempered with an engineering evaluation of the reasonableness of the assignment, and the PRA-based analysis can serve as only one ingredient of the overall decision.

One of the most important benefits of using PRA as an aid to assigning priorities is the documentation of a comprehensive and disciplined analysis of the issue, which enhances debate on the merits of specific aspects of the issue and reduces reliance on more subjective judgments. Clearly, some issues would be very difficult to quantify with reasonable accuracy, and the assignment of priorities

to these issues would have to be based largely on subjective judgment.

PRA is being usefully applied to setting priorities for generic safety issues and to evaluating new issues as they are identified. In this effort, each issue is assessed as to its nature, its probable core damage frequency and public risk, and the cost of one or more conceptual fixes that could resolve the issue. A matrix is developed whereby each issue is characterized as of high, medium, or low probability, or whether the issue should be summarily dropped from further regulatory consideration. This matrix considers both the absolute magnitude of the core damage frequency or risk and the value/impact ratio of conceptual fixes. Risk-reduction estimates are normally made using surrogate PWRs and BWRs, based on existing PRAs.

A principal benefit of PRA-based prioritization, compared to other methods for allocating resources to safety issues, is that important assumptions made in quantifying the risk are displayed and uncertainties in the analyses are estimated. A principal limitation is that some of the issues, such as those dealing with human factors, are only subjectively quantified. Thus, the uncertainties can be large. However, on balance, PRA-based prioritization has been found to be quite useful. Although uncertainties may be large, the process forces attention on these uncertainties to a much higher degree than if the quantification were not attempted. Also, the uncertainties are normally part of the issues themselves and not just an artifact of the PRA analysis.

Since, as discussed above, the prioritization is done on an approximate (order-of-magnitude) basis, the new information developed in NUREG-1150 is not expected to develop substantially change previously developed priority rankings. However, a sample of key issues will be re-examined to determine whether, based on the updated information in NUREG-1150, changes in dominant accident sequences or performance of mitigative systems could substantially affect the previous rankings.

13.3.3 Use of PRA in Inspections

The importance to NRC of risk-based inspection data is exemplified by the following statement in NRC's 5-Year Plan: "Probabilistic risk assessment techniques will be applied to all phases of the inspection program in order to insure that inspection activities are prioritized and conducted in an integrated fashion." Within NRC, the Risk Applications Branch of the Office of Nuclear Reactor Regulation has the responsibility of directly

providing risk-based information to the regional offices and resident inspectors. This ongoing effort has resulted in the development of plant-specific, and in some cases generic, PRA perspectives that help to provide an optimization of inspection resources and a prioritization of inspection resources on the high-risk aspects of a plant. Using draft NUREG-1150 data, team inspection procedures based on plant-specific PRA information have been developed and implemented on such plants as Grand Gulf. Formalization of these

inspection activities can be found in a recently issued inspection module entitled "Risk Focused Operation Readiness Inspection Procedures." This module focuses on how to use PRA perspectives and conduct a risk-based team inspection based on risk insights. The spectrum of reactor plant design types addressed in NUREG-1150 provide a broad risk data base that in many instances can be used to assist in inspection-type decisions even for plants without a PRA.

REFERENCES FOR CHAPTER 13

- 13.1 U.S. Nuclear Regulatory Commission (USNRC), "Integration Plan for Closure of Severe Accident Issues," SECY-88-147, May 25, 1988.
- 13.2 USNRC, "Reactor Safety Study—An Assessment of Accident Risks in U.S. Commercial Nuclear Power Plants," WASH-1400 (NUREG-75/014), October 1975.
- 13.3 D. M. Ericson, Jr., (Ed.) et al., "Analysis of Core Damage Frequency: Internal Events Methodology," Sandia National Laboratories, NUREG/CR-4550, Vol. 1, Revision 1, SAND86-2084, January 1990.
- 13.4 T. A. Wheeler et al., "Analysis of Core Damage Frequency from Internal Events: Expert Judgment Elicitation," Sandia National Laboratories, NUREG/CR-4550, Vol. 2, SAND86-2084, April 1989.
- 13.5 R. C. Bertucio and J. A. Julius, "Analysis of Core Damage Frequency: Surry Unit 1," Sandia National Laboratories, NUREG/CR-4550, Vol. 3, Revision 1, SAND86-2084, April 1990.
- 13.6 A. M. Kolaczowski et al., "Analysis of Core Damage Frequency: Peach Bottom Unit 2," Sandia National Laboratories, NUREG/CR-4550, Vol. 4, Revision 1, SAND86-2084, August 1989.
- 13.7 R. C. Bertucio and S. R. Brown, "Analysis of Core Damage Frequency: Sequoyah Unit 1," Sandia National Laboratories, NUREG/CR-4550, Vol. 5, Revision 1, SAND86-2084, April 1990.
- 13.8 M. T. Drouin et al., "Analysis of Core Damage Frequency: Grand Gulf Unit 1," Sandia National Laboratories, NUREG/CR-4550, Vol. 6, Revision 1, SAND86-2084, September 1989.
- 13.9 M. B. Sattison and K. W. Hall, "Analysis of Core Damage Frequency: Zion Unit 1," Idaho National Engineering Laboratory, NUREG/CR-4550, Vol. 7, Revision 1, EGG-2554, May 1990.
- 13.10 E. D. Gorham-Bergeron et al., "Evaluation of Severe Accident Risks: Methodology for the Accident Progression, Source Term, Consequence, Risk Integration, and Uncertainty Analyses," Sandia National Laboratories, NUREG/CR-4551, Vol. 1, Draft Revision 1, SAND86-1309, to be published.*
- 13.11 F. T. Harper et al., "Evaluation of Severe Accident Risks: Quantification of Major Input Parameters," Sandia National Laboratories, NUREG/CR-4551, Vol. 2, Revision 1, SAND86-1309, December 1990.
- 13.12 R. J. Breeding et al., "Evaluation of Severe Accident Risks: Surry Unit 1," Sandia National Laboratories, NUREG/CR-4551, Vol. 3, Revision 1, SAND86-1309, October 1990.
- 13.13 A. C. Payne, Jr., et al., "Evaluation of Severe Accident Risks: Peach Bottom Unit 2," Sandia National Laboratories, NUREG/CR-4551, Vol. 4, Draft Revision 1, SAND86-1309, to be published.*
- 13.14 J. J. Gregory et al., "Evaluation of Severe Accident Risks: Sequoyah Unit 1," Sandia National Laboratories, NUREG/CR-4551, Vol. 5, Revision 1, SAND86-1309, December 1990.
- 13.15 T. D. Brown et al., "Evaluation of Severe Accident Risks: Grand Gulf Unit 1," Sandia National Laboratories, NUREG/CR-4551, Vol. 6, Draft Revision 1, SAND86-1309, to be published.*
- 13.16 C. K. Park et al., "Evaluation of Severe Accident Risks: Zion Unit 1," Brookhaven National Laboratory, NUREG/CR-4551, Vol. 7, Draft Revision 1, BNL-NUREG-52029, to be published.*
- 13.17 USNRC, "Individual Plant Examination for Severe Accident Vulnerabilities—10 CFR §50.54(f)," Generic Letter 88-20, November 23, 1988.
- 13.18 USNRC, "Procedural and Submittal Guidance for the Individual Plant Examination of External Events (IPEEE) for Severe Accident Vulnerabilities," NUREG-1407, Draft Report for Comment, July 1990.

*Available in the NRC Public Document Room, 2120 L Street NW., Washington, DC.

- 13.19 USNRC, "Probabilistic Risk Assessment Reference Document," NUREG-1050, September 1984.
- 13.20 A. L. Camp et al., "The Risk Management Implications of NUREG-1150 Methods and Results," Sandia National Laboratories, NUREG/CR-5263, SAND88-3100, September 1989.
- 13.21 M. T. Drouin et al., "Analysis of Core Damage Frequency from Internal Events: Grand Gulf, Unit 1," Sandia National Laboratories, NUREG/CR-4550, Vol. 6, SAND86-2084, April 1987.
- 13.22 USNRC, "Safety Goals for the Operation of Nuclear Power Plants; Policy Statement," *Federal Register*, Vol. 51, p. 30028, August 21, 1986.
- 13.23 H. J. C. Kouts et al., "Special Committee Review of the Nuclear Regulatory Commission's Severe Accident Risks Report (NUREG-1150)," NUREG-1420, August 1990.
- 13.24 USNRC, "Categorization of Reactor Safety Issues from a Risk Perspective," NUREG-1115, March 1985.
- 13.25 R. Emrit et al., "A Prioritization of Generic Safety Issues," USNRC Report NUREG-0933, July 1984.

| | | | | | |
|--|---|---|------|----------|------|
| NRC FORM 335 (2-89) NRCM 1102, 3201, 3202 | U. S. NUCLEAR REGULATORY COMMISSION BIBLIOGRAPHIC DATA SHEET (See instructions on the reverse) | 1. REPORT NUMBER (Assigned by NRC, Add Vol., Supp., Rev., and Addendum Num- bers, if any.) NUREG-1150 Vol. 1 | | | |
| 2. TITLE AND SUBTITLE Severe Accident Risks: An Assessment for Five U.S. Nuclear Power Plants Final Summary Report | 3. DATE REPORT PUBLISHED | | | | |
| | <table border="1" style="width: 100%;"> <tr> <td style="width: 50%;">MONTH</td> <td style="width: 50%;">YEAR</td> </tr> <tr> <td style="text-align: center;">December</td> <td style="text-align: center;">1990</td> </tr> </table> | MONTH | YEAR | December | 1990 |
| | MONTH | YEAR | | | |
| December | 1990 | | | | |
| 4. FIN OR GRANT NUMBER | | | | | |
| 5. AUTHOR(S) | 6. TYPE OF REPORT Final Technical | | | | |
| | 7. PERIOD COVERED (Inclusive Dates) | | | | |
| 8. PERFORMING ORGANIZATION - NAME AND ADDRESS (If NRC, provide Division, Office or Region, U. S. Nuclear Regulatory Commission, and mailing address; If contractor, provide name and mailing address.) Division of Systems Research Office of Nuclear Regulatory Research U.S. Nuclear Regulatory Commission Washington, DC 20555 | | | | | |
| 9. SPONSORING ORGANIZATION - NAME AND ADDRESS (If NRC, type "Same as above"; If contractor, provide NRC Division, Office or Region, U. S. Nuclear Regulatory Commission, and mailing address.) Same as 8. above. | | | | | |
| 10. SUPPLEMENTARY NOTES | | | | | |
| 11. ABSTRACT (200 words or less) <p>This report summarizes an assessment of the risks from severe accidents in five commercial nuclear power plants in the United States. These risks are measured in a number of ways, including: the estimated frequencies of core damage accidents from internally initiated accidents, and externally initiated accidents for two of the plants; the performance of containment structures under severe accident loadings; the potential magnitude of radionuclide releases and offsite consequences of such accidents; and the overall risk (the product of accident frequencies and consequences). Supporting this summary report are a large number of reports written under contract to NRC which provide the detailed discussion of the methods used and results obtained in these risk studies.</p> <p>Volume 1 of this report has three parts. Part I provides the background and objectives of the assessment and summarizes the methods used to perform the risk studies. Part II provides a summary of results obtained for each of the five plants studied. Part III provides perspectives on the results and discusses the role of this work in the larger context of the NRC staff's work.</p> | | | | | |
| 12. KEY WORDS/DESCRIPTORS (List words or phrases that will assist researchers in locating the report.) severe accidents risk analysis probabilistic risk analysis | 13. AVAILABILITY STATEMENT Unlimited | | | | |
| | 14. SECURITY CLASSIFICATION (This Page) Unclassified (This Report) Unclassified | | | | |
| | 15. NUMBER OF PAGES | | | | |
| | 16. PRICE | | | | |

THIS DOCUMENT WAS PRINTED USING RECYCLED PAPER.